

# Memorandum

RECEIVED

2014 OCT 23 PM 4: 25

CITY SECRETARY  
DALLAS, TEXAS



CITY OF DALLAS

DATE October 24, 2014

TO Honorable Members of the Quality of Life & Environment Committee:  
Sandy Greyson (Vice Chair), Adam Medrano, Rick Callahan, Carolyn R. Davis, Lee M. Kleinman

SUBJECT Quality of Life & Environment Committee Meeting Agenda

**Monday, October 27, 2014, 9:00 a.m.**

Dallas City Hall - 6ES, 1500 Marilla St., Dallas, TX 75201

The agenda for the meeting is as follows:

- |  |   |
|--|---|
| 1. Call to Order                         | Dwaine R. Caraway<br>Chair  |
| 2. Special Recognition: World Stroke Day | Dwaine R. Caraway<br>Chair  |
| 3. Approval of September 8, 2014 Minutes | Dwaine R. Caraway<br>Chair  |
| 4. Gexa Energy Pavilion at Fair Park     | Willis Winters<br>Director, Park and Recreation                     |
| 5. Used Car Lots Air Registration Fees   | Rick Galceran<br>Director, Public Works                             |
| 6. Sustainability Plan Progress Report   | Frank Camp<br>Managing Director, Office of<br>Environmental Quality |
| 7. Adjourn                               | Dwaine R. Caraway<br>Chair  |

Please let me know if you have any questions.

Dwaine R. Caraway  
Chair

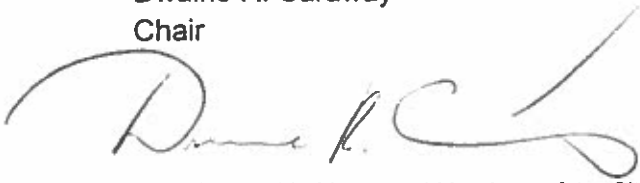

c: Honorable Mayor and Members of the City Council  
A.C. Gonzalez, City Manager  
Warren M.S. Ernst, City Attorney  
Craig D. Kinton, City Auditor  
Rosa A. Rios, City Secretary  
Daniel F. Solis, Administrative Judge  
Ryan S. Evans, First Assistant City Manager

Eric D. Campbell, Assistant City Manager  
Jill A. Jordan, P.E., Assistant City Manager  
Mark McDaniel, Assistant City Manager  
Joey Zapata, Assistant City Manager  
Jeanne Chipperfield, Chief Financial Officer  
Sana Syed, Public Information Officer  
Elsa Cantu, Assistant to the City Manager – Mayor & Council

**NOTICE:** A quorum of the Dallas City Council may attend this Council committee meeting.

A closed executive session may be held if the discussion of any of the above agenda items concerns one of the following:

1. Contemplated or pending litigation or matters where legal advice is requested of the City Attorney. Section 551.071 of the Texas Open Meetings Act.
2. The purchase, exchange, lease or value of real property, if the deliberation in an open meeting would have a detrimental effect on the position of the City in negotiations with a third person. Section 551.072 of the Texas Open Meetings Act.
3. A contract for a prospective gift or donation to the City, if the deliberation in an open meeting would have a detrimental effect on the position of the City in negotiations with a third person. Section 551.073 of the Texas Open Meetings Act.
4. Personnel matters involving the appointment, employment, evaluation, reassignment, duties, discipline or dismissal of a public officer or employee or to hear a complaint against an officer or employee. Section 551.074 of the Texas Open Meetings Act.
5. The deployment, or specific occasions for implementation of security personnel or devices. Section 551.076 of the Texas Open Meetings Act.

# Quality of Life & Environment Committee Meeting Record

**DRAFT**

**Meeting Date:** September 8, 2014      **Convended:** 9:18 a.m.      **Adjourned:** 10:22 a.m.

**Members Present:**

Dwaine R. Caraway, Chair  
Sandy Greyson, Vice Chair  
Lee M. Kleinman  
Adam Medrano  
Rick Callahan  
Carolyn R. Davis

**Members Absent:**

**Briefing Presenters**

Joey Zapata  
Assistant City Manager  
  
Willis Winters  
Director, Park and Recreation

**Staff Present:**

Joey Zapata, Mark McDaniel, Peter Bratt, Willis Winters, Eric Izuora, Priscylla Bento

**Special Guests:**

**AGENDA:**

**1. Approval of August 25, 2014 Minutes**

**Presenter(s):**

A motion was made to approve the minutes of August 25, 2014

**Action Taken/Committee Recommendation(s):**

**Motion made by:** Rick Callahan

**Motion seconded by:** Adam Medrano

**Item passed unanimously:**

**Item passed on a divided vote:**

**Item failed unanimously:**

**Item failed on a divided vote:**

**2. Recreation Master Plan and Comprehensive Plan Update**

**Presenter(s):**

Willis Winters

**Information Only**

This briefing provided the committee an overview of completed and planned staff actions taken to complete the Park and Recreation Department’s first Recreation Master Plan, and also reviewed actions taken and planned to update the Comprehensive Plan.

CM Greyson requested Mindmixer link for council member webpages.

**Action Taken/Committee Recommendation(s):**

**Motion made by:**

**Motion seconded by:**

**Item passed unanimously:**

**Item passed on a divided vote:**

**Item failed unanimously:**

**Item failed on a divided vote:**

**3. September 10, 2014 Consent Agenda for Water Utilities Capital Projects – Items #33 & #34**

**Presenter(s):**

Jo Puckett

**Information Only**

A briefing memo was provided for this item which was scheduled for the September 10, 2014 Council agenda.

**Action Taken/Committee Recommendation(s):**

Committee recommendation for approval on the September 10, 2014 Council Agenda.

**Motion made by:** Lee M. Kleinman

**Motion seconded by:** Dwaine R. Caraway

**Item passed unanimously:**

**Item passed on a divided vote:**

**Item failed unanimously:**

**Item failed on a divided vote:**

**3. Briefing Forecast**

**Presenter(s):**

Joey Zapata

**Information Only**

The committee was provided with a briefing memo that listed requested briefings for upcoming meetings.

Committee members provided input on the list of briefing topics and requested briefings from Code Compliance Services and Dallas Police Department that addresses areas of quality of life managed by each department.

**Action Taken/Committee Recommendation(s):**

**Motion made by:**

**Motion seconded by:**

**Item passed unanimously:**

**Item passed on a divided vote:**

**Item failed unanimously:**

**Item failed on a divided vote:**

---

**Councilmember Dwaine R. Caraway**  
Chair

# Memorandum



CITY OF DALLAS

DATE October 24, 2014

TO Honorable Members of the Quality of Life & Environment Committee: Dwaine R. Caraway (Chair)  
Sandy Greyson (Vice Chair), Adam Medrano, Rick Callahan, Carolyn R. Davis, Lee M. Kleinman

SUBJECT Gexa Energy Pavilion at Fair Park

On Monday, October 27, 2014 the Quality of Life & Environment Committee will be briefed on Gexa Energy Pavilion at Fair Park.

If you have questions, please contact me at 214-640-4071.

A handwritten signature in black ink that reads "Willis C. Winters".

Willis C. Winters, FAIA, Director  
Park and Recreation Department

## Attachment

c: Honorable Mayor and Members of the City Council  
A.C. Gonzalez, City Manager  
Warren M.S. Ernst, City Attorney  
Craig D. Kinton, City Auditor  
Rosa A. Rios, City Secretary  
Daniel F. Solis, Administrative Judge  
Ryan S. Evans, First Assistant City Manager

Eric D. Campbell, Assistant City Manager  
Jill A. Jordan, P.E., Assistant City Manager  
Mark McDaniel, Assistant City Manager  
Joey Zapata, Assistant City Manager  
Jeanne Chipperfield, Chief Financial Officer  
Sana Syed, Public Information Officer  
Elsa Cantu, Assistant to the City Manager – Mayor & Council

# Gexa Energy Pavilion at Fair Park

Quality of Life & Environment  
Committee

October 27, 2014



# Purpose

- To provide information to the City Council on proposed improvements and funding to the Gexa Energy Pavilion at Fair Park as approved by the Park and Recreation Board on October 2, 2014.



# Background

- Gexa Energy Pavilion is a City-owned facility at Fair Park managed and operated by the “Partnership”.
- Original Lease and Use Agreement between the City of Dallas and Pace Entertainment Group, Inc. (Partnership) entered into December 9, 1987
- Amendment to the Lease and Use Agreement entered into June 14, 1989
  - Term of twenty years, with two ten-year renewal options
  - Initial term expired December 31, 2008
  - On September 26, 2007, the Partnership served notice exercising the first ten-year option which is set to expire on December 31, 2018

# Background

- The Annual Minimum Guaranteed Rental to the City is \$350,000, plus percentage of all total revenues
- The Annual Minimum Guaranteed Rental to the City, plus percentage of all total revenues in FY 12-13 were \$965,897

# Background

- The Partnership is responsible for operating and managing the venue as a concert facility
  - Held 31 shows during the 2014 season (April-October)
    - 27 Live Nation tours including Lady Antebellum, Lionel Richie, Wiz Khalifa, Brad Paisley and Drake
    - 4 were locally booked concerts including Jack FM Throwback, KXT Summercut, and Texas Rap Fest
    - A draw of 352,479 concert-goers made it the third highest attendance generator at Fair Park in FY 13-14
  - The Partnership has brought over 1.4 million concert-goers to Fair Park over the last five years

# History of Amphitheater at Fair Park

- Constructed over 26 years ago
- One of the first outdoor amphitheaters built in the United States
- Largest public assembly venue in the Dallas/Ft. Worth market solely dedicated to hosting concerts
- Top venue in the Dallas/Ft. Worth metroplex for national and international touring artists



# Annual Revenue Summary

<b>• Fiscal Year</b>	<b>• Revenue Collected</b>
– 2003-04	– \$883,036
– 2004-05	– \$797,818
– 2005-06	– \$640,166
– 2006-07	– \$817,649
– 2007-08	– \$781,747
– 2008-09	– \$1,657,323*
– 2009-10	– \$941,530
– 2010-11	– \$863,271
– 2011-12	– \$701,262
– 2012-13	– \$965,897

\*Includes one-time audit finding

# Gexa Energy Pavilion Today

- Amphitheater has held up well functionally
  - Roof extends from the stage area to cover most of the reserved seated area
    - Approximately 7,400+ seats
    - 13,000 lawn seating capacity
  - Design and layout of the venue allows events to continue even in marginally inclement weather
- Time has taken its toll in terms of wear and tear on the venue



# Gexa Energy Pavilion Today

- The Partnership currently operates 40 amphitheaters across the United States, of which Gexa Energy Pavilion is the oldest venue
- No City capital improvements have been made since the opening of the facility in 1988.
- Improvements and major renovations to the venue are needed to:
  - Remain competitive in market
  - Continue to host major national and international touring artists
  - Provide concert-goers a safe and enjoyable venue

# Immediate Capital Needs vs. Funding

- The Partnership has studied proposed improvements to ensure Fair Park remains a desirable concert destination
  - Included in the plan are renovation of entrances, structural improvements, replacement of reserved seating, electrical upgrades, new LED video system, renovation of concession and merchandise stands, HVAC improvements, new sponsorship signage towers, replace fencing and repainting entire facility
  - Preliminary estimated renovation costs total \$6,510,240
- Next Bond Program likely in 2017 or beyond, with no guarantee that improvements to the Gexa Energy Pavilion will be funded



# Proposal

- The Partnership proposes to undertake capital improvement and revenue enhancing projects up to \$7,000,000 and exercise their second ten-year option extending through December 31, 2028
- The Partnership will submit plans and scope of projects to DPR-assigned project manager for review and approval.
- The Partnership agrees to comply with the City's Good Faith Effort goals in hiring and contracting with minority and women-owned local businesses

# Proposal Continued

- The Partnership proposes to begin construction of approved projects no later than December 1, 2016 and complete construction later than March 31, 2018
- City will grant the Partnership a credit against annual rents due under the Lease in an amount equal to the lesser of the actual costs of the approved completed projects or \$7,000,000 (rent credit)
  - Actual costs will include all soft and hard costs, including design, permitting, bonding, insurance, labor, equipment and materials

# Proposal Continued

- The rent credit shall commence in the calendar year that the first project costs are incurred.
- The rent credit will be taken in annual installments of \$500,000 annually (subject to only adjustment for any carry forward deficiencies resulting from the lack of total rent payable) until the full amount of rent credit is realized. Under no circumstance will the City be liable to pay any portion of the rent credit not sufficiently funded by the rents payable under the agreement
  - Example: If costs incurred for calendar year 2014 were \$2,000,000, in calendar year 2015 were \$3,000,000 and in calendar year 2016 were \$2,000,000 then the total rent credit would be \$7,000,000 with the first \$500,000 increment credited by the City against the rent payable due by Live Nation in 2014 and subsequent years until the full amount of the \$7,000,000 rent credit is realized

# Proposal Continued

- The Partnership agrees that in no event shall the rent credit reduce the amount of the annual Minimum Guaranteed Rental payable to the City of \$350,000
- The Partnership agrees to increase the current additional rental payment of \$.15 per paid admission tickets sold in accordance with the terms of the contract (Section 3.04) to \$.20 cents

# Mayor's Fair Park Task Force

- On September 3, 2014, the report of the Mayor's Fair Park Task Force was presented to the Dallas City Council and the Park and Recreation Board
- Task Force calls for creation of new non-profit organization as operational and marketing authority for Fair Park
  - All existing contracts, including Live Nation, will be reviewed by City Attorney's Office for assignability

# Next Steps

- City Council consideration for approval on November 12, 2014

# Memorandum



CITY OF DALLAS

DATE October 24, 2014

TO Honorable Members of the Quality of Life & Environment Committee: Dwaine R. Caraway (Chair)  
Sandy Greyson (Vice Chair), Adam Medrano, Rick Callahan, Carolyn R. Davis, Lee M. Kleinman

SUBJECT Used Car Lots Air Registration Fees

On Monday, October 27, the Quality of Life Committee will be briefed on the "Used Car Lots - Air Registration Fees." The briefing materials are attached for your review.

Please feel free to contact me if you have questions or need additional information.

A handwritten signature in black ink that reads "Jill A. Jordan".

Jill A. Jordan P.E.,  
Assistant City Manager

## Attachment

c: Honorable Mayor and Members of the City Council  
A.C. Gonzalez, City Manager  
Warren M.S. Ernst, City Attorney  
Craig D. Kinton, City Auditor  
Rosa A. Rios, City Secretary  
Daniel F. Solis, Administrative Judge  
Ryan S. Evans, First Assistant City Manager

Eric D. Campbell, Assistant City Manager  
Mark McDaniel, Assistant City Manager  
Joey Zapata, Assistant City Manager  
Jeanne Chipperfield, Chief Financial Officer  
Sana Syed, Public Information Officer  
Elsa Cantu, Assistant to the City Manager – Mayor & Council

# USED CAR LOTS

## Air Registration Fees

Briefing to:

Quality of Life &  
Environment Committee

October 27, 2014





# Purpose of Briefing

- 17 Sept 2014 Council meeting
  - Reviewed fee changes for ordinances changes
  - Raised specific questions related to increases in the “Used Car Lot” registration fees
- Briefing to address Council’s questions

# Background

- Federal Clean Air Act (FCAA) - the legal foundation for the national air pollution control program.
- The FCAA requires each state to produce a State Implementation Plan (SIP)



# Texas' State Implementation Plan (SIP)

- The SIP is required to include a description of *control strategies* to deal with air pollution.
- For the Texas SIP, these include:
  - Stationary sources
    - Decrease emissions from combustion sources, particulate matter, electric generation, other
  - Mobile Sources-
    - Reduce vehicle idling, conduct vehicle inspections
    - *Enact vehicle anti-tampering restrictions*
  - Many other criteria

# Local Agencies

- TCEQ may contract for air pollution control services
  - TX Health and Safety Code (THSC), Section 382.0622(d)(1)
  - May include compliance and permit inspections and complaint response
  - TCEQ may purchase service from local government
- TCEQ has delegated this authority to the City
  - TCEQ – CoD contracts date back over 20 years
  - Work is conducted under the Air Quality Compliance section of Public Works



# Texas Air Rules



- The state adopted legislation to control air pollution from motor vehicles. Current rules adopted Dec 1997.
- Reference specific to Used Car Lot Inspections:  
Texas Administrative Code(TAC) Title 30, Chapter 114, Subchapter B -  
Motor Vehicle Anti-Tampering Requirements.
- New cars are excluded from this rule:
- The commission may not require, as a condition precedent to the initial sale of a vehicle or vehicular equipment, the inspection, certification, or other approval of any feature or equipment designed to control emissions from motor vehicles if that feature or equipment has been certified, approved, or otherwise authorized under federal law. [THSC - Title 5, Subtitle C, Chap 382, Subchap. A, Sec 382.019(b) ]



# Texas Air Rules, cont'd



- TAC 30 Chapter 114, Subchap B - Motor Vehicle Anti- Tampering Requirements
- No person may sell, offer for sale, lease or offer to lease in the state of Texas any motor vehicle unless all of the following conditions are met:
  - 1) the vehicle **must be equipped with either the emission control system** or devices that were originally a part of the vehicle or engine or an alternate control system or device as specified in Regulation IV;
  - 2) the control systems or devices on the vehicle **must be in good operable condition;** and
  - 3) a **notice regarding these requirements shall be displayed** at all commercial vehicle sales facilities, vehicle consignment lots, and other businesses in Texas which sell, offer for sale, lease, or offer to lease more than three used vehicles per year.

**"State law prohibits any person from selling, offering for sale, leasing, or offering to lease any vehicle not equipped with all emission control systems or devices in good operable condition. Violators are subject to penalties under the Texas Clean Air Act of up to \$25,000 per violation."**

30TAC 114.20(c)(3)





# Exemptions

- Certain licensed used car dealers and individuals are exempt from the conditions outlined above when the vehicles would not be operated on public roads. These exemptions include:
  - 1) sales or transfers from one vehicle wholesale dealer to another;
  - 2) sale or transfers from a vehicle wholesale dealer to a vehicle retail dealer;
  - 3) sales, transfers, or trade-ins from an individual to a vehicle wholesale or retail dealer;
  - 4) sales or transfers from one retail dealer to another retail dealer; or
  - 5) sales or transfers from a retail dealer to a wholesale dealer.
- Federal, state, and local agencies or their agents which sell abandoned, confiscated, or seized vehicles and any commercial vehicle auction facility are also exempt from the rules if the following conditions are met:
  - 1) the vehicle safety sticker must be removed and destroyed;
  - 2) the potential buyer must be advised that there may be problems with the emission control equipment and of the buyer's responsibilities to restore or repair the equipment before operating or selling the vehicle; and
  - 3) the seller will have the buyer sign an acknowledgement that the information above was provided.
- Owners of motor vehicles which have been totally disabled by accident, age, or malfunction and which will no longer be operated are exempt from the rules. The vehicle must have non-emission related mechanical problems or extensive body and chassis damage. Vehicles which can be driven with minor repairs are not exempt.



# City of Dallas: Used Car Lot Inspections

- 350 car lots (approx.) in current inventory
- 200 lots inspected each FY (on average)
- Environmental Specialist arrives unannounced; provides ID & contact information to site manager; states purpose of visit.
- Specialist verifies Notice of Prohibition sign is posted in public view.
- Specialist inspects 10% of vehicles (with a min. of 2) that are;
  - More than 2 years old but made after 1975
  - Vehicles prior to 1975 - not required to have emission control systems
  - Vehicles less than 2 years old - still under original factory inspection
- Specialist notes vehicle's make, model, year, odometer reading, VIN, and types of air emission control equipment installed.





# What do we look at?

- **Vehicle Emission Control Information Decal**
  - Provides emission control data for that vehicle and engine; usually located under the hood but can be found elsewhere.
  - Some emission control systems are inaccessible to the investigator. For example (at right), an engine cover shrouds most of the engine; these are NOT to be removed by the investigator.



# Example of Decal



## Ford Motor Company VEHICLE EMISSION CONTROL INFORMATION

This vehicle conforms to U.S. EPA regulations applicable to 2005 model year new light-duty trucks and is certified for sale in California. ULEV qualified in California. OBD II certified.  
TWC/HO2S/EGR/SFI

**Attention:** Dyno Restrictions may apply.

**Adjustments:** Spark Plug Gap: See Spec Book.  
No other adjustments needed.

▽5C5E-9C485-

MSD



CATALYST

4.6L-Group: 5FMXT04.62FA  
Evap: 5FMXE0160GFF

### VACUUM HOSE ROUTING

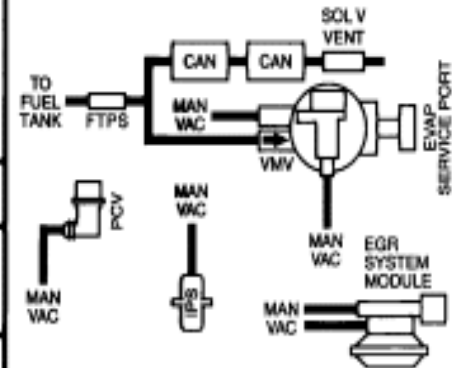

N0040783



# Under-the-Hood examples of emission controls

- Positive Crankcase Ventilation (PCV)
- Thermostatic Air Cleaner (TAC)
- Air Injection System (AIS)
- Evaporative Emission System (EVP)
- Exhaust Gas Recirculation (EGR)
- Computer Controls (CCO), aka Oxygen Sensors

# Vehicle Body examples of emission controls

- **Fuel fill pipe:** Fuel Fill Pipe Restrictor(FR)
- **Under the car body:**
  - Three-Way Catalyst (TWC)
  - Oxidation Catalyst (OC)
  - Computer Controls(CCO) aka Oxygen Sensors



# Emissions Controls

## in engine compartment

The **PCV valve** routes oil pan vapors to the intake manifold to be burned during combustion to prevent the buildup of the products of combustion in the engine oil and, thereby, reduce oil sludge.

The **TAC (thermostatic air cleaner)** controls the temperature of the air entering the engine, which optimizes the air/fuel ratio and minimizes exhaust emissions.

NOTE: TACs are installed on vehicles equipped with carburetors. Vehicles equipped with Fuel Injection systems are not equipped with TACs

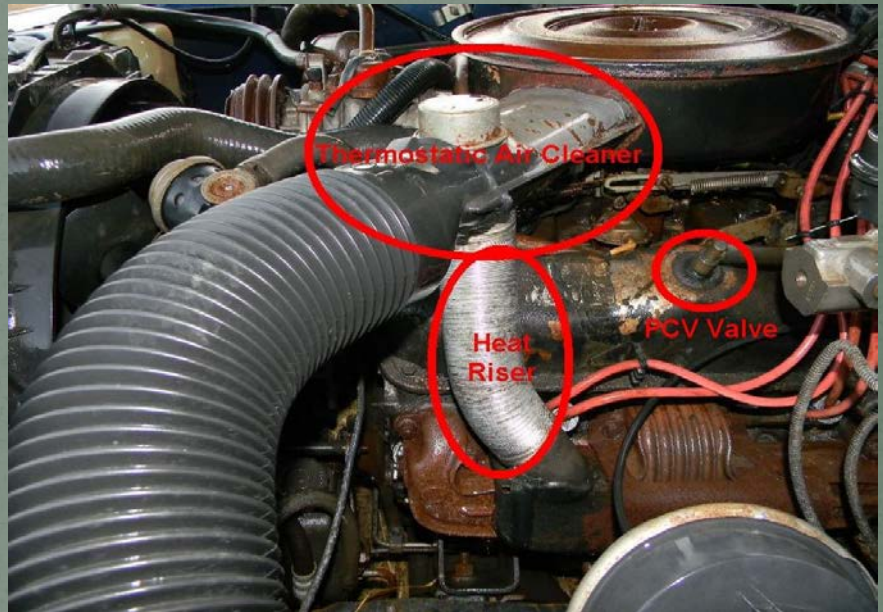



# Enforcement

- Following each inspection, the Environmental Specialist:
  - provides the lot owner with an “exit interview” form – identifying any non-compliance items
  - enters the inspection report into the TCEQ online report system
  - If needed, sends written NOV (Notice of Violation) by mail to the lot owner
- NOV stipulates the concern; requires action in 30 days
- Specialist re-inspects following the 30-day period
- Violations are rare (<1%)
  - Only 1-2 NOVs issued each year
  - Owners aware of requirements; expect to see inspector annually
  - Typical NOV is for “Notice” sign being posted improperly

## How the Annual Safety Inspection differs from Used Car Lot Investigations

	<b>New vehicle</b> < 2-years old	<b>Used vehicle</b> 2-years old or more	<b>Notes</b>
<b>Annual Safety Inspection</b>			
<b>Operational checks</b> (brakes, horn, lights, turn signals, etc.)	Dealership verifies	Various service centers	For used cars: The annual inspection is conducted at the request of the vehicle owner, to coincide with its annual inspection month.
<b>Tailpipe emissions</b> (for carbon monoxide, carbon dioxide, nitrous oxides, hydrocarbons)	Dealership verifies	Various service centers	
<b>Periodic <i>Visual</i> Review at Used Car Lots</b>			
- <b>Emission equipment present?</b>	NA	City Air Inspector	For used cars: The periodic visual inspection is conducted by City staff at Used Car Lots only, and on a rotating schedule.
- <b>Emission equipment tampered with?</b>	NA	City Air Inspector	
- <b>Signage posted?</b>	NA	City Air Inspector	



# Fee Changes

	Service Name	FY14 Fees	FY 15 Fee
1	Used Car Lot Annual registration (3 or less spaces)	\$0	Combine with Category 2 fee rate
2	Used Car Lot Annual registration (4 to 9 spaces)	\$165	\$200
3	Used Car Lot Annual registration (10 to 49 spaces)	\$215	\$245
4	Used Car Lot Annual registration (50 or more spaces)	\$260	\$295



# Questions and Discussion .....

# Memorandum



CITY OF DALLAS

DATE October 24, 2014

TO Honorable Members of the Quality of Life & Environment Committee:  
Dwayne R. Caraway (Chair), Sandy Greyson (Vice Chair), Rick Callahan, Carolyn R. Davis, Lee M. Kleinman, Adam Medrano

SUBJECT **Sustainability Plan Progress Report**

On Monday, October 27, 2014, the Quality of Life & Environment Council Committee will be briefed on a progress report for the City's Sustainability Plan.

The following materials are attached for your review:

1. Sustainability Plan Progress Report Briefing
2. Sustainability Progress Report, October 27, 2014

If you have any questions or require additional information, please do not hesitate to contact me.

A handwritten signature in black ink, appearing to read 'Jill Jordan'.

Jill A. Jordan, P.E.  
Assistant City Manager

c: The Honorable Mayor and Members of the City Council  
A.C. Gonzalez, City Manager  
Warren M.S. Ernst, City Attorney  
Rosa A. Rios, City Secretary  
Daniel F. Solis, Administrative Judge  
Craig D. Kinton, City Auditor  
Ryan S. Evans, First Assistant City Manager  
Eric D. Campbell, Assistant City Manager  
Joey Zapata, Assistant City Manager  
Mark McDaniel, Assistant City Manager  
Jeanne Chipperfield, Chief Financial Officer  
Sana Syed, Public Information Officer  
Elsa Cantu, Assistant to the City Manager – Mayor and Council

# Sustainability Plan Progress Report

Quality of Life and Environment Committee  
October 27, 2014

Presented by the Office of Environmental Quality



# Organization

- Purpose page 3
- Why Sustainability? page 4
- Need page 5
- Content Format page 6
- Moving Forward page 20



# Purpose

- Report on progress of Sustainability Plan
- Highlight next steps

# Why Sustainability?

- Sustainability planning is more than compliance with the law.
- It is the process by which we think broader, plan smarter, and act better to ensure we are leaving a stronger, healthier, and more resilient Dallas for all generations.

# The Need for a Sustainability Plan

- Citizens of Dallas want an efficient, responsive government that forecasts needs and responds accordingly to build a stronger city
- Present progress on environmental goals, EMS progress, and Strategic Plan work to the City Council and the public

# Format of Progress Report

- Goal description within each of these five categories
  - Air Quality: Improve Air Quality
  - Land Use: Promote Smart Growth and Development
  - Water Quality: Improve Water Quality
  - Materials Management: Better Materials Management
  - Energy Management: Reduce Non-Renewable Energy Use
- Individual objectives with strategies and targets for achieving categorical goals
- Results for each target



# AIR QUALITY: IMPROVE AIR QUALITY

AIR QUALITY GOAL: IMPROVE AIR QUALITY		
Objective: I. Increase alternative commute options		
Strategy	Target	Results
<ul style="list-style-type: none"> <li>Promote Green Ride.</li> </ul>	<ul style="list-style-type: none"> <li>Reduction in single-rider vehicle miles travelled by 10% annually over previous year through 2014 (OEQ, EMS O&amp;T 00992).</li> </ul>	<ul style="list-style-type: none"> <li>In 2010: 3.14M miles/1,478 tons CO2 reduced.</li> <li>In 2011: 3.70M miles/1,560 tons CO2 reduced.</li> <li>In 2012: 1.81M miles/851 tons CO2 reduced.</li> <li>In 2013: 3.39M miles/1,594 tons CO2 reduced.</li> <li>In 2014: 2.38M miles/1,096 tons CO2 reduced.</li> <li>Total reduction in CO2: 6,579 tons.</li> </ul>
<ul style="list-style-type: none"> <li>Expand street car service.</li> </ul>	<ul style="list-style-type: none"> <li>Completion of McKinney Avenue Trolley Loop in 2014 (SDC, Strategic Plan, CAR 2).</li> </ul>	<ul style="list-style-type: none"> <li>McKinney Avenue Trolley loop extension project construction is anticipated to be complete in December 2014. Testing will occur in January/February followed by revenue service</li> </ul>
	<ul style="list-style-type: none"> <li>Initiate TIGER streetcar service and Urban Circulator streetcar service (SDC, Strategic Plan, CAR 2).</li> </ul>	<ul style="list-style-type: none"> <li>Phase I TIGER Oak Cliff/Downtown streetcar project construction is complete; two to three months of integrated testing will occur when the first streetcar vehicle is delivered, anticipated late January/February 2015). Revenue service anticipated April/May 2015.</li> <li>Phase II TIGER Southern Extension from Methodist Hospital to Bishop Arts anticipates construction beginning with utility relocation in January 2015. Project construction proposed to be completed by December 31, 2015.</li> <li>Phase III TIGER Northern Extension of the Union Station/Omni Loop proposed to begin construction July 2015 with anticipated completion in April 2016.</li> <li>Urban Circulator project anticipated to be complete December 2014; revenue service anticipated February/March 2015 following project testing.</li> </ul>
<ul style="list-style-type: none"> <li>Promote bicycling.</li> </ul>	<ul style="list-style-type: none"> <li>Completion of 7.5 miles of bike lanes in 2014 (PBW, EMS O&amp;T 01102).</li> </ul>	<ul style="list-style-type: none"> <li>In 2012: 8 miles of bike and shared lanes completed.</li> <li>In 2013: 10 miles of bike and shared lanes completed.</li> <li>In 2014: 12 miles of bike and shared lanes scheduled to be completed.</li> </ul>

Objective: 2. Reduce emissions from vehicles		
Strategy	Target	Results
<ul style="list-style-type: none"> <li>Replace fleet with alternative fuel vehicles to reduce emissions.</li> </ul>	<ul style="list-style-type: none"> <li>Replacement of 15% of Sanitation Services' fleet with alternative fuel vehicles by September 2014 (SAN, EMS O&amp;T 01023).</li> </ul>	<ul style="list-style-type: none"> <li>As of July, 2014, Sanitation's fleet is 395 vehicles of which 13% are CNG. In June 2014, City Council approved the purchase of 18 CNG trucks for delivery in FY14-15.</li> </ul>
	<ul style="list-style-type: none"> <li>Reduction of NOx, VOC, PM and CO2 emissions by 5% from on-road and off-road vehicles through vehicle replacement by September 2015 (EBS, EMS O&amp;T 00961).</li> </ul>	<ul style="list-style-type: none"> <li>The FY12-13 fleet purchase replaced 53 traditionally-fueled vehicles. The FY13-14 fleet purchase identified 22 vehicles to be replaced with alternative fuel vehicles, anticipated arrival by the end of December 2014.</li> <li>Fleet Emission Tool established September 2014 to calculate emission reductions for new O&amp;T 01114 for FY14-15.</li> </ul>
	<ul style="list-style-type: none"> <li>Reduction of fossil fuel consumption for by 1% by September 2015 (SAN, EMS O&amp;T 01055).</li> </ul>	<ul style="list-style-type: none"> <li>FY11-12 baseline: 492,149 gallons. FY12-13: 6% reduction in fuel usage to target year. FY13-14: 5% reduction in fuel usage to target year.</li> </ul>
	<ul style="list-style-type: none"> <li>Replacement of 10% of transfer station diesel fleet by September 2015 (SAN, EMS O&amp;T 01058).</li> </ul>	<ul style="list-style-type: none"> <li>FY13-14: SAN has replaced 11 vehicles with cleaner vehicles.</li> </ul>
<ul style="list-style-type: none"> <li>Enforce and educate around the anti-idling ordinance.</li> </ul>	<ul style="list-style-type: none"> <li>Continue education efforts and messaging on social media. Offer anti-idling signs and educational materials to schools (OEQ).</li> </ul>	<ul style="list-style-type: none"> <li>OEQ posted information on GreenDallas.net and in the Green Times newsletter, and sent 254 letters to schools in FY11-12.</li> <li>Messages around air quality impacts posted to GreenDallas.net: 31 on air quality, 12 on transportation; and Facebook and Twitter accounts: 48 postings total.</li> </ul>

<b>Objective: 3. Reduced emissions from industry</b>		
Strategy	Target	Results
<ul style="list-style-type: none"> <li>Reduce air emissions through industrial process inspections.</li> </ul>	<ul style="list-style-type: none"> <li>Inspection of 600 industrial sources of emissions annually through October 2014 (PBW, EMS O&amp;T 01020).</li> </ul>	<ul style="list-style-type: none"> <li>In FY11-12, PBW completed 750 inspections. In FY12-13, PBW completed 843 inspections. In FY13-14, PBW completed 715 inspections.</li> </ul>

# LAND USE: PROMOTE SMART GROWTH AND DEVELOPMENT

<b>LAND USE GOAL: PROMOTE SMART GROWTH AND DEVELOPMENT</b>		
<b>Objective: 1. Build “green” in Dallas</b>		
Strategy	Target	Results
<ul style="list-style-type: none"> <li>Reduce impact of construction in Dallas.</li> </ul>	<ul style="list-style-type: none"> <li>Track construction of new buildings over 10,000 square feet through September 2014 (PBW, EMS O&amp;T 00665).</li> </ul>	<ul style="list-style-type: none"> <li>Since February 2012, 9 City facilities have been completed, another 5 have received LEED certification, another 2 have applied for LEED certification, and another 8 buildings began construction. To date, 29 City facilities are LEED certified and 20 projects are registered.</li> </ul>
<b>Objective: 2. Open space acquisition</b>		
Strategy	Target	Results
<ul style="list-style-type: none"> <li>Procure land for new parks and open space.</li> </ul>	<ul style="list-style-type: none"> <li>Continued development of neighborhood park projects per the capital funding schedule in FY13-14 (PKR, Strategic Plan, CHE 7).</li> </ul>	<ul style="list-style-type: none"> <li>Construction award/COs: \$8,628,723 at 34 parks. Parks has completed 73% of their 2006 bond projects and has 18% progressing.</li> </ul>
<ul style="list-style-type: none"> <li>Amend and update the Tree Ordinance.</li> </ul>	<ul style="list-style-type: none"> <li>Revision of the Tree Preservation Ordinance to address increasing the urban tree canopy in Dallas (SDC, Strategic Plan, CHE 8).</li> </ul>	<ul style="list-style-type: none"> <li>Formal amendment process initiated, deliberation and discussion by Zoning Ordinance Committee will be initiated in November 2014 and target City Plan Commission consideration in 1<sup>st</sup> quarter 2015.</li> </ul>



<b>Objective: 3. Development and redevelopment</b>		
Strategy	Target	Results
<ul style="list-style-type: none"> <li>Use MSD and economic tools to promote redevelopment and/or brownfield reclamation.</li> </ul>	<ul style="list-style-type: none"> <li>Completion of internal processing of MSD applications within nine months, excluding applicant response time to City comments (OEQ).</li> </ul>	<ul style="list-style-type: none"> <li>In FY11-12, 7 MSDs were presented to Council; 5 of these MSDs were processed within 9 months (staff review time) and 2 took longer. In FY12-13, 1 MSD went to Council; 18 months to process. In FY13-14, 7 MSDs were presented to Council; one of these MSDs was processed within 9 months (staff review time) and 6 took longer.</li> </ul>
<b>Objective: 4. Create sustainable food systems</b>		
Strategy	Target	Results
<ul style="list-style-type: none"> <li>Develop land use policies that will guide placement and operation of community gardens on City land.</li> </ul>	<ul style="list-style-type: none"> <li>Creation of land use policy governing community gardens on City land in 2014 (OEQ).</li> </ul>	<ul style="list-style-type: none"> <li>OEQ has met with internal representatives and community groups and stakeholders to discuss use of City owned property for placement of Community Gardens.</li> <li>Libraries exploring option to be the pilot model upon which to build a policy.</li> </ul>
<ul style="list-style-type: none"> <li>Work with food groups, community organizers, and businesses to identify needs and opportunities to increase access to healthy food options.</li> </ul>	<ul style="list-style-type: none"> <li>Identification of strategies to increase access to healthy food options to address “food deserts” in 2014 (OEQ).</li> </ul>	<ul style="list-style-type: none"> <li>OEQ staff has met with and is working with local food groups to address “food deserts” by exploring redevelopment of brownfield locations into community gardens and placement of market gardens throughout the city.</li> <li>OEQ is working with food groups to develop changes to City code to allow for more sustainable food systems.</li> </ul>

# WATER QUALITY: IMPROVE WATER QUALITY

<b>WATER QUALITY GOAL: IMPROVE WATER QUALITY</b>		
<b>Objective: 1. Trinity River preservation</b>		
Strategy	Target	Results
<ul style="list-style-type: none"> <li>Restore natural contour of River to allow for filtration.</li> </ul>	<ul style="list-style-type: none"> <li>Commencement of the Trinity River relocation in the Dallas Floodway to create a more natural channel (TWM, Balanced Vision Plan).</li> </ul>	<ul style="list-style-type: none"> <li>Dallas Floodway environmental impact study anticipated to be complete in spring 2015, providing opportunity for the Corps to begin design efforts for river relocation, dependent upon federal funding.</li> </ul>
<ul style="list-style-type: none"> <li>Restore creeks to natural state.</li> </ul>	<ul style="list-style-type: none"> <li>Look for day lighting opportunities (TWM, Strategic Plan, CHE 8).</li> </ul>	<ul style="list-style-type: none"> <li>Consultant's investigation of Mill Creek complete. Work underway to preserve Big Spring. Anticipate Landmark Commission and Council action to be requested by early summer 2015.</li> </ul>
<b>Objective: 2. Protect surface waters</b>		
Strategy	Target	Results
<ul style="list-style-type: none"> <li>Implement integrated pest management (IPM).</li> </ul>	<ul style="list-style-type: none"> <li>Development of IPM for City facilities by September 2014 (TWM, EMS O&amp;T 01097).</li> </ul>	<ul style="list-style-type: none"> <li>The IPM Administrative Directive Plan has been updated by TAMU Extension Service. Review is scheduled for October 2014 by affected city departments with a target to present to Council by the end of calendar 2014.</li> </ul>
<ul style="list-style-type: none"> <li>Inspect for compliance and enforce existing regulations that protect the Trinity River watershed.</li> </ul>	<ul style="list-style-type: none"> <li>Reduce pollutant load at McCommas Bluff Landfill by 5% from 2007 baseline by September 2014 (SAN, EMS O&amp;T 00986).</li> </ul>	<ul style="list-style-type: none"> <li>As of 2013, decrease of 11.5% for Total Suspended Solids (TSS) and a 9.5% decrease for Iron versus 2007 baseline. As of July 2014, decrease of 13.91% for TSS and 12.72% for Iron versus 2007 baseline.</li> </ul>

Objective: 3. Education and outreach																													
Strategy	Target	Results																											
<ul style="list-style-type: none"> <li>Continue education and outreach, and associated line cleanings, to reduce sanitary sewer overflows.</li> </ul>	<ul style="list-style-type: none"> <li>Continuation of the Cease the Grease program and completion of the cleaning of 36% of city's sanitary sewer lines by October 2014 (DWU, Performancesoft Measure).</li> </ul>	<ul style="list-style-type: none"> <li>The Cease the Grease program is ongoing. There were 307 outreach events that took place in FY13-14.</li> </ul> <table border="1"> <thead> <tr> <th colspan="9">Number of Fats, Oils, Greases (FOG) related Sanitary Sewer Overflows by year</th> </tr> <tr> <th>FY05-06</th> <th>FY06-07</th> <th>FY07-08</th> <th>FY08-09</th> <th>FY09-10</th> <th>FY10-11</th> <th>FY11-12</th> <th>FY12-13</th> <th>FY13-14</th> </tr> </thead> <tbody> <tr> <td>112</td> <td>42</td> <td>39</td> <td>15</td> <td>8</td> <td>2</td> <td>3</td> <td>6</td> <td>1</td> </tr> </tbody> </table> <ul style="list-style-type: none"> <li>In FY11-12, 1,792 miles or 44.6% of sanitary sewer cleaned. In FY12-13, 1,549 miles or 38.6% of sanitary sewer cleaned. In FY13-14, 1,557 miles or 38.8% of sanitary sewer cleaned.</li> </ul>	Number of Fats, Oils, Greases (FOG) related Sanitary Sewer Overflows by year									FY05-06	FY06-07	FY07-08	FY08-09	FY09-10	FY10-11	FY11-12	FY12-13	FY13-14	112	42	39	15	8	2	3	6	1
Number of Fats, Oils, Greases (FOG) related Sanitary Sewer Overflows by year																													
FY05-06	FY06-07	FY07-08	FY08-09	FY09-10	FY10-11	FY11-12	FY12-13	FY13-14																					
112	42	39	15	8	2	3	6	1																					
<ul style="list-style-type: none"> <li>Provide education and outreach to residents and businesses.</li> </ul>	<ul style="list-style-type: none"> <li>Delivery of 72 outreach presentations on reducing pollution by OEQ annually through September 2014 (OEQ, Performancesoft Measure).</li> </ul>	<ul style="list-style-type: none"> <li>In FY11-12, 64 event requests were received and completed. In FY12-13, 89 event requests were received and completed. In FY13-14, 83 events have been completed on the importance of environmental stewardship and sustainability.</li> </ul>																											

# MATERIALS MANAGEMENT: BETTER MATERIALS MGMT

MATERIALS MANAGEMENT GOAL: BETTER MATERIALS MANAGEMENT		
Objective: I. Increase “household” recycling		
Strategy	Target	Results
<ul style="list-style-type: none"> <li>Increase household recycling rates citywide.</li> </ul>	<ul style="list-style-type: none"> <li>Increase the residential recycling participation rate from 73% to 74% (SAN, Strategic Plan, CHE 5).</li> </ul>	<ul style="list-style-type: none"> <li>The baseline was Q4 of FY11-12 where the rate was 70.4%. (EMS O&amp;T 01056).</li> <li>Residential recycling participation rate is currently at 75.1%.</li> </ul>
	<ul style="list-style-type: none"> <li>Increase in the tons recycled by 30% over FY09-10 totals by September 2013 (SAN, EMS O&amp;T 01022).</li> </ul>	<ul style="list-style-type: none"> <li>FY09-10 total tonnage recycled: 45,152 tons. In FY10-11, the total tonnage recycled: 48,983. In FY11-12, the total tonnage recycled: 51,300. In FY12-13, the total tonnage recycled: 53,280. In FY13-14, the total tonnage recycled: 53,638.</li> <li>Progress made over FY09-10: 18.8%. Sanitation has increased social media outreach and is targeting areas with low participation to increase the recycling tonnage. They are also expanding outreach to multi-family residents and promoting the community container program.</li> </ul>
<ul style="list-style-type: none"> <li>Increase recycling rates at City facilities.</li> </ul>	<ul style="list-style-type: none"> <li>Increase in the percentage of solid waste that is recycled by 5% per year at Love Field through 2014 (AVI, EMS O&amp;T 00706).</li> </ul>	<ul style="list-style-type: none"> <li>Love Field continues to promote recycling in the terminal and has identified practices to increase recycling volume in staff areas. New contract terms with waste haulers will require monthly volume and weight reports for Love Field. With the modernization project completing, a new baseline number will be established to be used going forward to capture realized results.</li> </ul>
	<ul style="list-style-type: none"> <li>Increase in paper recycling by 3% annually at Detention Center by September 2014 (DMO, EMS O&amp;T 01025).</li> </ul>	<ul style="list-style-type: none"> <li>In FY11-12, 2,195 pounds of paper collected and recycled. In FY12-13, 2,901 pounds of paper collected and recycled. In FY13-14, 3,320 pounds of paper collected and recycled.</li> </ul>
	<ul style="list-style-type: none"> <li>Increase in the recycling throughout DPD by 2% over the baseline year FY11-12 through September 2014 (DPD, EMS O&amp;T 01045).</li> </ul>	<ul style="list-style-type: none"> <li>DPD recycling has increased due to increased employee involvement. DPD established a baseline of 86,205 pounds. In FY11-12, DPD recycled 120,210 pounds. In FY12-13, DPD recycled 172,870 pounds.* In FY13-14, DPD recycled 137,750 pounds.</li> </ul>

\*Includes one-time housekeeping of scrap metal bullet casings from gun range.



<b>Objective: 2. Process waste management</b>		
Strategy	Target	Results
<ul style="list-style-type: none"> <li>Implement process waste minimization programs.</li> </ul>	<ul style="list-style-type: none"> <li>Increase scrap metal recycling by 10% of FY11-12 baseline annually by September 2017 (DWU, EMS O&amp;T 01027).</li> </ul>	<ul style="list-style-type: none"> <li>In FY11-12, DWU recycled 669,320 pounds of scrap metal. In FY12-13, DWU recycled 926,920 pounds of scrap metal. In FY13-14, DWU recycled 1,097,840 pounds of scrap metal.</li> </ul>
	<ul style="list-style-type: none"> <li>Increase in the amount of beneficial re-use items diverted from the landfill by 3% over FY08-09 baseline by September 2012 (SAN, EMS O&amp;T 00989).</li> </ul>	<ul style="list-style-type: none"> <li>The following items were reused:                      In FY11-12, asphalt, 6,987 tons; concrete, 9,097 tons; glass 3,496 tons; and, sawdust 983 tons.                      In FY12-13, asphalt, 19,362 tons; concrete, 10,831 tons; glass, 2,633 tons; and, sawdust, 2,118 tons.                      In FY13-14, asphalt, 25,655 tons; concrete, 30,548 tons; glass, 5,483 tons; 200% increase in diversion over baseline of 20,559 tons.</li> </ul>
<b>Objective: 3. Hazardous waste management</b>		
Strategy	Target	Results
<ul style="list-style-type: none"> <li>Reduce hazardous waste impacts to the environment.</li> </ul>	<ul style="list-style-type: none"> <li>Completion of two household hazardous waste collection events annually (SAN, Strategic Plan, CHE 5).</li> </ul>	<ul style="list-style-type: none"> <li>In FY11-12, COD participated in 5 collection events. In FY12-13, COD participated in 3 collection events and 2 batteries, oils, paints, &amp; antifreeze (BOPA) collections. In FY13-14, COD participated in 2 collection events and 9 BOPA collections.</li> </ul>

Objective: 4. Conserve water		
Strategy	Target	Results
<ul style="list-style-type: none"> <li>Reduce average consumption.</li> </ul>	<ul style="list-style-type: none"> <li>Completion of 45 audits and issuance of incentives for DWU customers under the industrial, commercial and institutional incentive program (DWU, Strategic Plan, CHE 5).</li> </ul>	<ul style="list-style-type: none"> <li>In FY13-14, 47 audits were conducted. One application was submitted and approved for \$17,000.00 to Texas Instruments. Funds will be issued when water savings project has been completed.</li> </ul>
	<ul style="list-style-type: none"> <li>Reduction in the average gallons per capita per day (gpcd) demand by 1.5% over FY10-11 by September 2015 (DWU, EMS O&amp;T 01028).</li> </ul>	<ul style="list-style-type: none"> <li>5 year average is 199 gpcd.</li> <li>FY12-13: 187 gpcd realized.</li> <li>FY13-14: 182 gpcd realized; a reduction of 2.7%.</li> </ul>
<ul style="list-style-type: none"> <li>Reduce water waste through inspection of mains.</li> </ul>	<ul style="list-style-type: none"> <li>Inspection of 2,500 miles of water main line annually for leaks (DWU, EMS O&amp;T 00537).</li> </ul>	<ul style="list-style-type: none"> <li>In FY11-12, 3,729 miles of main inspected. In FY12-13, 4,315 miles of main inspected; 440 leaks found. In FY13-14, 4,691 miles of main inspected; 308 leaks found.</li> </ul>
<ul style="list-style-type: none"> <li>Use highly treated effluent for reuse.</li> </ul>	<ul style="list-style-type: none"> <li>Increase in the amount of highly treated wastewater effluent reused per day by 5 million gallons by September 2014 (DWU, EMS O&amp;T 01006).</li> </ul>	<ul style="list-style-type: none"> <li>In FY10-11, 84,784,700 gallons reused. In FY11-12, 60,219,300 gallons reused; MGD=0.164984. In FY12-13, 55,562,000 gallons reused; MGD=0.152225. In FY13-14, 36,173,000 gallons reused; MGD=0.099104.</li> </ul>

Objective: 5. Green purchasing		
Strategy	Target	Results
<ul style="list-style-type: none"> <li>Buy green to minimize resource impacts.</li> </ul>	<ul style="list-style-type: none"> <li>Increase in the number of less toxic chemicals available through the Product Substitution Program by 4% by September 2014 (EBS, EMS O&amp;T 01031).</li> </ul>	<ul style="list-style-type: none"> <li>The Green Procurement Approved List has increased to 373 items approved for purchase. This is a 13.5% increase over the FY09-10 baseline.</li> <li>EBS held a Green Procurement Committee meeting in July 2014 to discuss green procurement activities with EBS, DFR, DPD, STS, TWMM, and SAN to help reduce the use of hazardous chemicals at City facilities.</li> </ul>
	<ul style="list-style-type: none"> <li>Develop and implement a fuel conservation program by September 2014 (EBS, EMS O&amp;T 01052).</li> </ul>	<ul style="list-style-type: none"> <li>FY10-11 baseline: 7,126,723 gallons. In FY11-12, 6,630,024 gal used – 6.97% reduction v FY10-11. In FY12-13, 6,905,499 gal used – 3.11% reduction v FY10-11. In FY13-14, a 4.3% reduction realized v FY10-11.</li> </ul>
	<ul style="list-style-type: none"> <li>Implement a Product Substitution Program to reduce toxic chemicals by 25% annually by September 2016 (CIS, EMS O&amp;T 01100).</li> </ul>	<ul style="list-style-type: none"> <li>CIS maintains 36 chemicals in inventory; 14 chemicals have been designated as replaceable or no longer needed. With the use and/or disposal of these 14 items, projection is 42% of chemicals will be replaced with less toxic products.</li> </ul>

# ENERGY MANAGEMENT: REDUCE NON-RENEWABLE ENERGY USE

<b>ENERGY MANAGEMENT GOAL: REDUCE NON-RENEWABLE ENERGY USE</b>		
<b>Objective: 1. Purchase green energy</b>		
Strategy	Target	Results
<ul style="list-style-type: none"> <li>Continue purchasing renewable energy.</li> </ul>	<ul style="list-style-type: none"> <li>Purchase of at least 50% of the City's energy from renewable energy sources (PBW, Strategic Plan, CHE 4).</li> </ul>	<ul style="list-style-type: none"> <li>City has purchased 50% renewable energy for contract years 2014, 2015, 2016 under Renewable Energy Program.</li> <li>Estimates project this purchase will reduce the City GHG emissions by over 270,000 tons of CO2e per year.</li> <li>City of Dallas is number 4 in top 30 Local Government on EPA Green Power Partnership.</li> </ul>
<b>Objective: 2. Energy conservation</b>		
Strategy	Target	Results
<ul style="list-style-type: none"> <li>Maintain EMS conservation efforts to achieve a 5% reduction in City usage annually.</li> </ul>	<ul style="list-style-type: none"> <li>Reduction in average electric energy use per million gallons treated at wastewater treatment plants from FY08-09 baseline by December 2013 (DWU, EMS O&amp;T 01029).</li> </ul>	<ul style="list-style-type: none"> <li>FY08-09: average electric use: 1,671 kWh/Mgallons.</li> <li>FY09-10: average electric use: 1,663 kWh/Mgallons.</li> <li>FY10-11: average electric use: 1,802 kWh/Mgallons.</li> <li>FY11-12: average electric use: 2,792 kWh/Mgallons.</li> <li>FY12-13: average electric use: 2,222 kWh/Mgallons.</li> <li>FY13-14: average electric use: 2,281 kWh/Mgallons.</li> </ul>
	<ul style="list-style-type: none"> <li>Reduce monthly electrical demand and peak hour charges of ERCOT load during 4-CP (4-Coincident Peaks) months (June-September) by October 2014 (DWU, EMS O&amp;T 01068).</li> </ul>	<ul style="list-style-type: none"> <li>2011 baseline is 30,126 KWD.</li> <li>During 2012 season, 20,712 kWD used.</li> <li>During 2013 season, 22,105 kWD used.</li> <li>During 2014 season, 11,015 kWD estimated use.</li> </ul>
	<ul style="list-style-type: none"> <li>Replace traffic light bulbs with energy efficient LED lights by December 2014 (STS, EMS O&amp;T 01091).</li> </ul>	<ul style="list-style-type: none"> <li>2,453 incandescent traffic light bulbs have been replaced with energy efficient LED light bulbs between October 2013 and June 2014.</li> <li>LED lights use between 70% to 90% less energy; retrofits for FY13-14 are estimated to save \$100,000/year in electricity costs.</li> </ul>



Objective: 3. Produce energy on-site		
Strategy	Target	Results
<ul style="list-style-type: none"> <li>Conduct feasibility research and develop a plan to generate energy at City facilities.</li> <li>Explore the construction of solar installations.</li> </ul>	<ul style="list-style-type: none"> <li>Development of an on-site energy production plan by October 2014 (PBW, Strategic Plan, CHE 4).</li> </ul>	<ul style="list-style-type: none"> <li>PBW is working with Pepco Energy Services to develop a citywide Energy Management Plan, including solar and other onsite energy production.</li> </ul>
	<ul style="list-style-type: none"> <li>Determination of the feasibility for solar installations by October 2014 (PBW, Strategic Plan, CHE 4).</li> </ul>	<ul style="list-style-type: none"> <li>Three PV projects were combined into the Convention Center Solar Project. Installations at City Hall, Jack Evans Police Headquarters, and Convention Center have been designed. The City received SECO loan funding and approval of the ONCOR rebate application. However, the project is not financially feasible without additional funding. PBW is still exploring options.</li> <li>PBW initiated solar procurement at SSWWTP and continues to develop more projects where they are economically feasible. Currently evaluating a project for solar at the Morton H. Meyerson Symphony Center.</li> </ul>

# Moving Forward

- Sustainability Plan will be revised annually
  - Strategic Plan elements
  - Environmental Objectives and Targets
  - Other strategies and programs
- OEQ will report progress

# Questions





# SUSTAIN ABILITY

*n:* living today  
to be sure  
there is enough  
for tomorrow

# PROGRESS REPORT

October 27, 2014



**DALLAS SUSTAINABILITY PLAN**

**Contents**

Introduction ..... 1

Air Quality..... 4

**Goal..... 5**

**AIR QUALITY SUMMARY OF OBJECTIVES ..... 7**

Land Use ..... 9

**Goal..... 10**

**LAND USE SUMMARY OF OBJECTIVES..... 12**

Water Quality ..... 14

**Goal..... 15**

**WATER QUALITY SUMMARY OF OBJECTIVES ..... 17**

Materials Management..... 18

**Goal..... 19**

**MATERIALS MANAGEMENT SUMMARY OF OBJECTIVES..... 21**

Energy Management ..... 24

**Goal..... 25**

**ENERGY MANAGEMENT SUMMARY OF OBJECTIVES ..... 27**

Conclusion..... 29

Appendices ..... 30

**Green Your Life: City of Dallas Programs ..... 31**

**Green Your Life: Tips & Tools ..... 32**

**Selected City Council Ordinances, Resolutions and Authorizations ..... 34**

**City Environmental Policy ..... 35**



## Dallas City Council

standing (l-r): Scott Griggs, 1; Sandy Greyson, 12; Lee M. Kleinman, 11; Rick Callahan, 5; Jennifer Staubach Gates, 13; Sheffie Kadane, 9; Philip T. Kingston, 14; Dwaine R. Caraway, 4

seated (l-r): Vonciel Jones Hill, 3; Jerry R. Allen, 10; Deputy Mayor Pro Tem, Monica R. Alonzo, 6; Mayor Mike Rawlings; Mayor Pro Tem, Tennell Atkins, 8; Adam Medrano, 2; Carolyn R. Davis, 7



## Introduction

The City of Dallas recognizes that to promote a vibrant, healthy future, it must actively balance economic needs, environmental stewardship and social equity. Dallas needs a robust and thriving economy to ensure families are self-sufficient, and it must protect the cultural and social identities that are the fabric of community. But to do this, Dallas must protect the environment to ensure that all can enjoy the prosperity and access the resources shared today for generations to come. To be successful protecting the environment, a multi-faceted approach is required: reduce the impact from what is used, use only what is needed, and replenish resources faster than they are used.

Dallas is the largest component of the Dallas-Fort Worth-Arlington metropolitan statistical area (MSA), which is currently the fourth largest MSA in the United States. The Dallas region continues to grow as more people move here to take advantage of the many opportunities North Texas has to offer. With that growth, more demands will be made of the natural environment. In an effort to be proactive and to preserve Dallas, *our Dallas*, this sustainability plan is offered to educate and inform on the steps the City as an organization and the city as a community can take to help create a prosperous future for all.

### Sustainability Priorities

To begin, five areas where activities have an impact have been identified: air quality, land use, water quality, materials management and energy. City leaders, since the 1950s, have, in one form or another, put in place measures or plans to address the impacts from the use of the resources in these five areas. As in those previous plans, this plan will showcase what is intended to be accomplished through environmental stewardship efforts and the policies in place that will help reach those goals.

### Sustainability, the Strategic Plan and Environmental Management

The City Council's FY13-14 Strategic Plan was driven by the six Key Focus Areas (KFAs) the City Council has identified as the roadmaps to creating a successful city. Every year, Council meets to affirm the priorities of each KFA and to identify the programs they feel best move the city toward fulfilling those priorities. From there, the City's Strategic Plan is updated to reflect the Council's goals, and the great work begins.

Enhancing the vitality and quality of life for everyone in Dallas is the ultimate goal of this sustainability plan. Reflecting on the Strategic Plan and the vision of a *City That Works: Diverse, Vibrant, Progressive*, the sustainability plan espouses the City's Core Values of accountability, commitment, customer service, environmental stewardship, innovation, integrity, leadership, sensitivity and teamwork in order to achieve the objectives framed within.





The core value of Environmental Stewardship establishes the foundations by which the City of Dallas builds a Clean, Healthy Environment.

As one of the six Key Focus Areas which govern City activities and budget allocations, the concept of a Clean, Healthy Environment is critical to the future success of the City of Dallas. Although the other Key Focus Areas of Public Safety; Economic Vibrancy; Culture, Arts, & Recreation; Educational Enhancements; and, E-3 Government are equally important, this plan will focus on the cornerstone of it all – a Clean, Healthy Environment.







A Clean, Healthy Environment in Dallas will be accomplished through Municipal Leadership, Regional Collaboration, Environmental Initiatives, and Community Enhancement. The strategy map shown in *Figure 1* highlights the major strategies and activities that the City of Dallas uses to promote a “culture of health and cleanliness.”



**Figure 1**

effectiveness of the alternative methods at accomplishing those activities with a minimized or eliminated environmental impact. And “Acting” allows for continual improvements to be made through further planning.

**DALLAS CITY COUNCIL  
FY13-14 KEY FOCUS AREAS**

-  CLEAN, HEALTHY ENVIRONMENT
-  CULTURE, ARTS, & RECREATION
-  ECONOMIC VIBRANCY
-  EDUCATIONAL ENHANCEMENTS
-  E3 GOVERNMENT
-  PUBLIC SAFETY

To demonstrate its commitment as an organization to protecting the environment, the City has implemented an Environmental Management System (EMS) to guide internal operations. The EMS is a system based on a continual cycle of “Plan, Do, Check, Act” as shown in *Figure 2* that requires us to minimize negative environmental impacts. Through “Planning”, one identifies activities that will have an environmental impact and then comes up with alternative methods to accomplish those activities but with a lessened or altogether eliminated environmental impact. By “Doing”, one implements the alternative methods and trains others on the process to ensure consistency. Regular “Checking” ensures the



Fourteen City departments participate in the EMS and work closely with the City's Office of Environmental Quality to keep the system running optimally. In January of 2005, the City Council approved an Environmental Policy, found in Appendix D, which empowers every employee, not just those in the EMS, to minimize their environmental footprint in every aspect of their jobs and to go above and beyond to protect the environment, making Earth Day Every Day in Dallas.

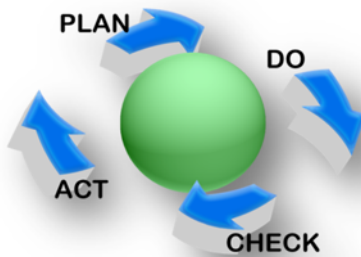

Figure 2

This sustainability plan is the culmination of years of commitment and dedication to the environment within the City of Dallas as an organization through the work of City departments and the Environmental Management System paired with elements of the Strategic Plan to expand sustainability into daily decision making

processes to build a stronger community for today and tomorrow.

This plan is designed to inform the reader of the steps already taken and the direction in which to proceed as well as serving as a road map for those wishing to green their lives and ensure a bright and prosperous future for years to come.

### Plan Outline

The City of Dallas' sustainability plan is divided into five categories that address a range of issues relating to sustainability: Air Quality, Land Use, Water Quality, Materials Management, and Energy Management. Each section of the plan includes an introduction to the topic, including the guiding principles and goal, and information on how the City of Dallas will take action to address the issue through programmatic objectives.

Four appendices are included that contain a listing of City of Dallas Programs, Tips & Tools, Selected City Council Ordinances, Resolutions and Authorizations and Administrative Directives, and the City's Environmental Policy.





## Air Quality

Air quality impacts everyone every day. As pollution is released from human activities the world over, its impact can be seen on health and climate.

Today, children and the elderly spend much of their time indoors because of daily warnings about poor air quality. According to the Centers for Disease Control (CDC), roughly one in twelve Americans suffer from asthma<sup>1</sup>. Children are most prone to asthma, and respiratory ailments remain the number one reason youth under the age of eighteen visit emergency rooms in the United States. It is estimated that asthma cost the United States \$56 billion in 2007, up from \$53 billion in 2002, due to medical costs, lost school and work days, and early deaths<sup>1</sup>.

While the public debate around the impact human activities have on the climate continues, more greenhouse gases build in the atmosphere. As a result, less solar radiation is able to escape back into space, and the atmosphere, like a pot with a lid, consequently warms. With a warmer climate come changes in weather patterns including fluctuations from normal temperatures and precipitation levels. It also causes coral bleaching, warmer seas, oceanic acidification, and shorter cold weather seasons that leave pest populations intact leading to economic and health costs associated with lost crops and the spread of insect borne diseases like West Nile virus and Chikungunya.

Everyone is familiar with “the haze” that can be seen over Dallas. The haze is the byproduct of internal combustion and sunlight. Emissions from the combustion of fossil fuels mix with volatile organic compounds in the presence of sunlight to produce ground-level ozone which then becomes trapped in place by weather patterns. In the stratosphere, ozone protects the planet from ultraviolet radiation; at the surface, it is an eyesore and a dangerous irritant to lung tissue.

The Dallas-Fort Worth-Arlington area has over six million individuals making an impact, positively or negatively to air quality, as a result of everyday actions.

Emissions are local, but their impact is regional. As air quality standards become more stringent, this region may face financial sanctions from governing authorities if steps are not taken to help improve air quality and bring the region into full attainment with the National Ambient Air Quality Standards of the Clean Air Act.

The City of Dallas will continue to implement programs aimed to help reduce the amount of emissions that are associated with City operations to help further reduce air quality impacts.

The City continues to encourage and partner with surrounding communities and businesses in the region to do what they can to help reduce

---

<sup>1</sup><http://www.cdc.gov/VitalSigns/Asthma/index.html>

their own impact to air quality to build a better, healthier future for us all.

## Goal

***The City of Dallas is working to improve air quality.***

### Objective 1

Improve air quality: the City is promoting the use of alternative commutes - including mass transit, carpooling, biking and walking - to reduce emissions and minimize single-rider vehicle trips.

#### Strategy:

Utilize *GreenRide* to assist staff to find carpool or biking buddies to reduce single-rider trips. *GreenRide* allows staff to track their alternative commutes, records emissions reductions and calculates reductions in vehicle miles travelled (VMT) and emission reductions of CO<sub>2</sub> and other greenhouse gases (GHG) based on the type of vehicle and distances travelled.

Expand the street car system to reach further into the community, coupled with expansion plans of Dallas Area Rapid Transit (DART), to increase interconnectivity between points all over Dallas and the surrounding areas to reduce single-rider trips.

Increase bicycle access in Dallas.

#### Target:

Reduction in single-rider vehicle miles travelled by 10% annually over previous year through 2014 (OEQ, EMS O&T 00992).

Completion of McKinney Avenue Trolley Loop in 2014 (SDC, Strategic Plan, CAR 2).

Initiate TIGER streetcar service and Urban Circulator streetcar service (SDC, Strategic Plan, CAR 2).

Completion of 7.5 miles of bike lanes in 2014 (PBW, EMS O&T 01102).

### Objective 2

Improve air quality: the City is reducing emissions from vehicles.

#### Strategy:

Continue purchasing alternative fuels and upgrading fleet vehicles with those that can operate on alternative fuels or hybrids of gasoline and electricity to reduce emissions.

Educate parents and bus drivers at schools on the impacts of idling and encourage voluntary engine shut-down.

#### Target:

Replacement of 15% of Sanitation Services fleet with alternative fuel vehicles by September 2014 (SAN, EMS O&T 01023).

Reduction of NO<sub>x</sub>, VOC, PM and CO<sub>2</sub> emissions by 5% from on-road and off-road vehicles through vehicle replacement by September 2015 (EBS, EMS O&T 00961).

Reduction of fossil fuel consumption for by 1% by September 2015 (SAN, EMS O&T 01055).

Replacement of 10% of transfer station diesel fleet by September 2015 (SAN, EMS O&T 01058).

Continue education efforts and messaging on social media. Offer anti-idling signs and educational materials to schools (OEQ).

### Objective 3

Improve air quality: the City promotes reducing emissions from community sources through compliance with regulations, process improvements and equipment replacement. Inspection of facilities and equipment coupled with replacement of aged or non-compliant equipment will minimize emissions.

#### Strategy:

City staff enforces sections of the Clean Air Act by monitoring industrial sources of air emissions for compliance with permit restrictions on the quantity of emissions allowed.

#### Target:

Inspection of 600 industrial sources of air pollution by October 2014 (PBW, EMS O&T 01020).

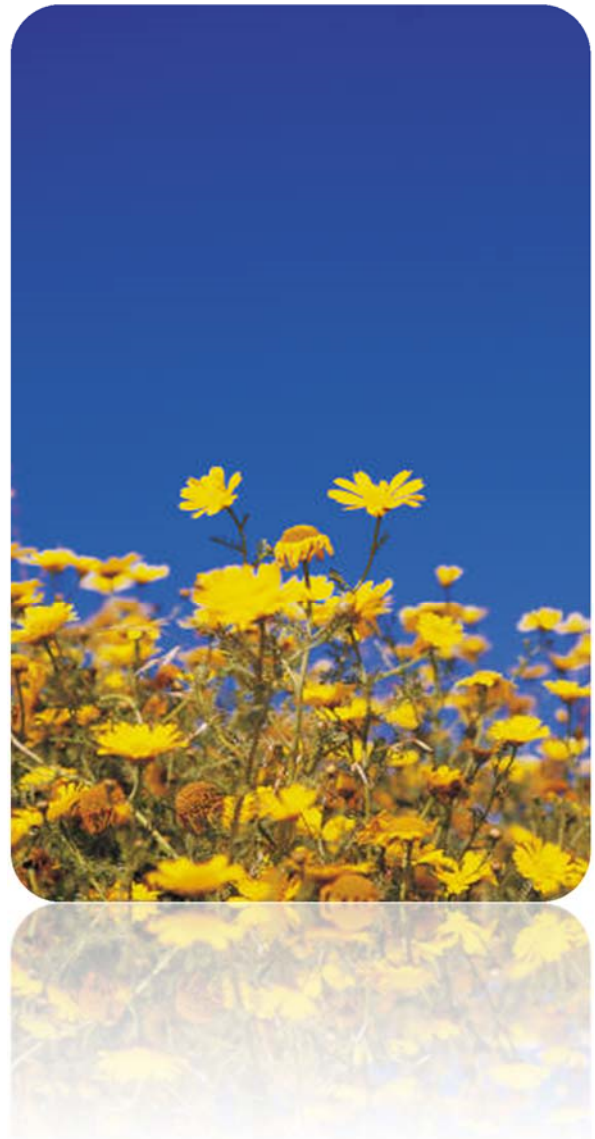

## AIR QUALITY SUMMARY OF OBJECTIVES

**AIR QUALITY GOAL:  
IMPROVE AIR QUALITY**
**Objective: I. Increase alternative commute options**

Strategy	Target	Results
<ul style="list-style-type: none"> <li>Promote Green Ride.</li> </ul>	<ul style="list-style-type: none"> <li>Reduction in single-rider vehicle miles travelled by 10% annually over previous year through 2014 (OEQ, EMS O&amp;T 00992).</li> </ul>	<ul style="list-style-type: none"> <li>In 2010: 3.14M miles/1,478 tons CO2 reduced.</li> <li>In 2011: 3.70M miles/1,560 tons CO2 reduced.</li> <li>In 2012: 1.81M miles/851 tons CO2 reduced.</li> <li>In 2013: 3.39M miles/1,594 tons CO2 reduced.</li> <li>In 2014: 2.38M miles/1,096 tons CO2 reduced.</li> <li>Total reduction in CO2: 6,579 tons.</li> </ul>
<ul style="list-style-type: none"> <li>Expand street car service.</li> </ul>	<ul style="list-style-type: none"> <li>Completion of McKinney Avenue Trolley Loop in 2014 (SDC, Strategic Plan, CAR 2).</li> <li>Initiate TIGER streetcar service and Urban Circulator streetcar service (SDC, Strategic Plan, CAR 2).</li> </ul>	<ul style="list-style-type: none"> <li>McKinney Avenue Trolley loop extension project construction is anticipated to be complete in December 2014. Testing will occur in January/February followed by revenue service.</li> <li>Phase I TIGER Oak Cliff/Downtown streetcar project construction is complete; two to three months of integrated testing will occur when the first streetcar vehicle is delivered, anticipated late January/February 2015). Revenue service anticipated April/May 2015.</li> <li>Phase II TIGER Southern Extension from Methodist Hospital to Bishop Arts anticipates construction beginning with utility relocation in January 2015. Project construction proposed to be completed by December 31, 2015.</li> <li>Phase III TIGER Northern Extension of the Union Station/Omni Loop proposed to begin construction July 2015 with anticipated completion in April 2016.</li> <li>Urban Circulator project anticipated to be complete December 2014; revenue service anticipated February/March 2015 following project testing.</li> </ul>
<ul style="list-style-type: none"> <li>Promote bicycling.</li> </ul>	<ul style="list-style-type: none"> <li>Completion of 7.5 miles of bike lanes in 2014 (PBW, EMS O&amp;T 01102).</li> </ul>	<ul style="list-style-type: none"> <li>In 2012: 8 miles of bike and shared lanes completed.</li> <li>In 2013: 10 miles of bike and shared lanes completed.</li> <li>In 2014: 12 miles of bike and shared lanes scheduled to be completed.</li> </ul>



<b>Objective: 2. Reduce emissions from vehicles</b>		
Strategy	Target	Results
<ul style="list-style-type: none"> <li>Replace fleet with alternative fuel vehicles to reduce emissions.</li> </ul>	<ul style="list-style-type: none"> <li>Replacement of 15% of Sanitation Services' fleet with alternative fuel vehicles by September 2014 (SAN, EMS O&amp;T 01023).</li> </ul>	<ul style="list-style-type: none"> <li>As of July, 2014, Sanitation's fleet is 395 vehicles of which 13% are CNG. In June 2014, City Council approved the purchase of 18 CNG trucks for delivery in FY14-15.</li> </ul>
	<ul style="list-style-type: none"> <li>Reduction of NOx, VOC, PM and CO2 emissions by 5% from on-road and off-road vehicles through vehicle replacement by September 2015 (EBS, EMS O&amp;T 00961).</li> </ul>	<ul style="list-style-type: none"> <li>The FY12-13 fleet purchase replaced 53 traditionally-fueled vehicles. The FY13-14 fleet purchase identified 22 vehicles to be replaced with alternative fuel vehicles, anticipated arrival by the end of December 2014.</li> <li>Fleet Emission Tool established September 2014 to calculate emission reductions for new O&amp;T 01114 for FY14-15.</li> </ul>
	<ul style="list-style-type: none"> <li>Reduction of fossil fuel consumption for by 1% by September 2015 (SAN, EMS O&amp;T 01055).</li> </ul>	<ul style="list-style-type: none"> <li>FY11-12 baseline: 492,149 gallons. FY12-13: 6% reduction in fuel usage to target year. FY13-14: 5% reduction in fuel usage to target year.</li> </ul>
	<ul style="list-style-type: none"> <li>Replacement of 10% of transfer station diesel fleet by September 2015 (SAN, EMS O&amp;T 01058).</li> </ul>	<ul style="list-style-type: none"> <li>FY13-14: SAN has replaced 11 vehicles with cleaner vehicles.</li> </ul>
<ul style="list-style-type: none"> <li>Enforce and educate around the anti-idling ordinance.</li> </ul>	<ul style="list-style-type: none"> <li>Continue education efforts and messaging on social media. Offer anti-idling signs and educational materials to schools (OEQ).</li> </ul>	<ul style="list-style-type: none"> <li>OEQ posted information on GreenDallas.net and in the Green Times newsletter, and sent 254 letters to schools in FY11-12.</li> <li>Messages around air quality impacts posted to GreenDallas.net: 31 on air quality, 12 on transportation; and Facebook and Twitter accounts: 48 postings total.</li> </ul>
<b>Objective: 3. Reduced emissions from industry</b>		
Strategy	Target	Results
<ul style="list-style-type: none"> <li>Reduce air emissions through industrial process inspections.</li> </ul>	<ul style="list-style-type: none"> <li>Inspection of 600 industrial sources of emissions annually through October 2014 (PBW, EMS O&amp;T 01020).</li> </ul>	<ul style="list-style-type: none"> <li>In FY11-12, PBW completed 750 inspections. In FY12-13, PBW completed 843 inspections. In FY13-14, PBW completed 715 inspections.</li> </ul>



## Land Use

Land use, in the scope of sustainability, is much more than the development of real estate. Land provides a place to live, grow food, nurture family, and create community. Land is the foundation upon which to build and shape community and cultural identity.

In Dallas, people value the features that create a community's identity. One can easily identify the parts of Dallas that are named after their environmental features: *Oak Cliff, White Rock, Lakewood, Forest Hills, Oak Lawn, Cedars, Lake West, Pleasant Grove, Bluffview, Elderwoods, Turtle Creek, Oak Highlands, Walnut Hill*, to name a few. Effort is made to protect these areas and their identities through civic action and, in some cases, regulations. The White Rock Escarpment, one of Dallas's signature geological formations, is protected under Article V of the city code from any development or site alteration to protect it always.

It is important to protect the land to ensure its proper use and the use of the resources it provides – not just growth for the sake of growth but growth for a substantial and sustainable purpose. For the most part, Dallas is landlocked and has matured to understand the importance of finding a balance between preserving what has defined and shaped the contextual make up of the community and the need for future growth.

*forwardDallas!* was adopted to help guide that balance and ensure Dallas continues to remain economically vibrant while connected to its heritage. Article X of the city code was passed to protect the trees that shade Dallas, provide natural habitat, and help clean the air. By

adopting long range plans and passing ordinances to protect natural resources, Dallas will arrive at its future while preserving its past.

As more people move to Dallas, they will need more places to live and work. Over time, city leaders will be afforded the opportunity to demonstrate their commitment to preserving natural resources by embracing the land use principles that will ensure smart growth and keep the city economically strong while maintaining and protecting the features that make it unique.

Such opportunities will include the continued promotion of transit-oriented design (TOD) in Dallas and the promotion of mixed-use developments that allow for the creation of urban centers where individuals can live, work and play. So important is this effort to Dallas' sustainable future, financial incentives toward this goal were considered for inclusion in the 2012 bond issue. Leaders may also wish to explore ways to preserve neighborhood identity around those areas perhaps through the use of a neighborhood stabilization overlay (NSO) for all properties within a pre-determined distance of any City-assisted development project. The City could also develop a strategy to promote the restoration of historically designated structures to green standards to prevent demolition by neglect.

When approving land use, city leaders have to balance the needs of the entire community against the needs of those who seek to make Dallas home. Whether it is new homes or a new retail center, leaders must weigh all the benefits and drawbacks to each proposed use so as to get

the most from each parcel for the community economically while protecting the very qualities that made the parcel desirable to the community.



## Goal

***The City of Dallas promotes smart growth and development.***

### Objective 1

Promote smart growth and development: the City promotes the use of green building practices to minimize a building's construction and use impacts on the environment, City infrastructure, and the surrounding community.

#### Strategy:

Reduce impact of construction in Dallas.

#### Target:

Track construction of new buildings over 10,000 square feet through September 2014 (PBW, EMS O&T 00665).

### Objective 2

Promote smart growth and development: the City will work to secure and preserve in perpetuity open, green spaces for common uses like parks and trails and the Trinity River Corridor.

#### Strategy:

Procure land for new parks and future projects, including neighborhood parks and open spaces.

Amend and update the Tree Ordinance to protect and expand the existing tree canopy in Dallas.

#### Target:

Continued development of neighborhood park projects per the capital funding schedule in FY13-14 (PKR, Strategic Plan, CHE 7).

Revision of the Tree Preservation Ordinance to address increasing the urban tree canopy in Dallas (SDC, Strategic Plan, CHE 8).

### Objective 3

Promote smart growth and development: the City encourages redevelopment of brownfields and other areas with historical contamination.

#### Strategy:

Use municipal setting designation (MSD), alone or coupled with economic development tools and grants, to foster redevelopment of brownfields and other areas in Dallas.

#### Target:

Completion of internal processing of MSD applications within nine months, excluding applicant response time to City comments (OEQ).

### Objective 4

Promote smart growth and development: promote sustainable food systems including community gardens, neighborhood markets and mobile food options in Dallas.

#### Strategy:

Develop land use policies that will guide placement and operation of community gardens on City land.

Work with food groups, community organizers, and businesses to identify needs and opportunities to increase access to healthy food options.

**Target:**

Creation of land use policy governing community gardens on City land in 2014 (OEQ).

Identification of strategies to increase access to healthy food options to address “food deserts” in 2014 (OEQ).



Green buildings provide an average 30% reduction in energy use, as compared with minimum energy code requirements. For energy costs of \$1.47/sqft/yr, this indicates savings of about \$0.44/sqft/yr.

source: <http://www.usgbc.org/ShowFile.aspx?DocumentID=1992>



## LAND USE SUMMARY OF OBJECTIVES

### LAND USE GOAL:

### PROMOTE SMART GROWTH AND DEVELOPMENT

#### Objective: 1. Build “green” in Dallas

Strategy	Target	Results
<ul style="list-style-type: none"> <li>Reduce impact of construction in Dallas.</li> </ul>	<ul style="list-style-type: none"> <li>Track construction of new buildings over 10,000 square feet through September 2014 (PBW, EMS O&amp;T 00665).</li> </ul>	<ul style="list-style-type: none"> <li>Since February 2012, 9 City facilities have been completed, another 5 have received LEED certification, another 2 have applied for LEED certification, and another 8 buildings began construction. To date, 29 City facilities are LEED certified and 20 projects are registered.</li> </ul>

#### Objective: 2. Open space acquisition

Strategy	Target	Results
<ul style="list-style-type: none"> <li>Procure land for new parks and open space.</li> </ul>	<ul style="list-style-type: none"> <li>Continued development of neighborhood park projects per the capital funding schedule in FY13-14 (PKR, Strategic Plan, CHE 7).</li> </ul>	<ul style="list-style-type: none"> <li>Construction award/COs: \$8,628,723 at 34 parks. Parks has completed 73% of their 2006 bond projects and has 18% progressing.</li> </ul>
<ul style="list-style-type: none"> <li>Amend and update the Tree Ordinance.</li> </ul>	<ul style="list-style-type: none"> <li>Revision of the Tree Preservation Ordinance to address increasing the urban tree canopy in Dallas (SDC, Strategic Plan, CHE 8).</li> </ul>	<ul style="list-style-type: none"> <li>Formal amendment process initiated, deliberation and discussion by Zoning Ordinance Committee will be initiated in November 2014 and target City Plan Commission consideration in 1<sup>st</sup> quarter 2015.</li> </ul>

#### Objective: 3. Development and redevelopment

Strategy	Target	Results
<ul style="list-style-type: none"> <li>Use MSD and economic tools to promote redevelopment and/or brownfield reclamation.</li> </ul>	<ul style="list-style-type: none"> <li>Completion of internal processing of MSD applications within nine months, excluding applicant response time to City comments (OEQ).</li> </ul>	<ul style="list-style-type: none"> <li>In FY11-12, 7 MSDs were presented to Council; 5 of these MSDs were processed within 9 months (staff review time) and 2 took longer. In FY12-13, 1 MSD went to Council; 18 months to process. In FY13-14, 7 MSDs were presented to Council; one of these MSDs was processed within 9 months (staff review time) and 6 took longer.</li> </ul>

#### Objective: 4. Create sustainable food systems

Strategy	Target	Results
<ul style="list-style-type: none"> <li>Develop land use policies that will guide placement and operation of community gardens on City land.</li> </ul>	<ul style="list-style-type: none"> <li>Creation of land use policy governing community gardens on City land in 2014 (OEQ).</li> </ul>	<ul style="list-style-type: none"> <li>OEQ has met with internal representatives and community groups and stakeholders to discuss use of City owned property for placement of Community Gardens.</li> <li>Libraries exploring option to be the pilot model upon which to build a policy.</li> </ul>

**Objective: 4. Create sustainable food systems (continued)**

Strategy	Target	Results
<ul style="list-style-type: none"> <li>Work with food groups, community organizers, and businesses to identify needs and opportunities to increase access to healthy food options.</li> </ul>	<ul style="list-style-type: none"> <li>Identification of strategies to increase access to healthy food options to address “food deserts” in 2014 (OEQ).</li> </ul>	<ul style="list-style-type: none"> <li>OEQ staff has met with and is working with local food groups to address “food deserts” by exploring redevelopment of brownfield locations into community gardens and placement of market gardens throughout the city.</li> <li>OEQ is working with food groups to develop changes to City code to allow for more sustainable food systems.</li> </ul>



## Water Quality

Until the Clean Water Act (CWA) started regulating discharges to American waters, rivers, streams and lakes were used as disposal sites to move industrial and commercial waste away from communities. History is replete with incidences where this practice resulted in undesirable side-effects that prompted the federal government to act to protect water and ensure its availability. Even with regulations now in place, many bodies of water in the United States remain threatened or “impaired” under the Clean Water Act either from decades old contamination that is persistent and accumulative, or from non-point sources that exist today.

Improving water quality requires understanding how it is impacted.

According to the Texas Commission on Environmental Quality, bacteria and chemical concentrations are occasionally elevated in portions of the Upper Trinity River (Segment 0805) that flows through Dallas. This places the River in an “impaired” state for activities identified as “contact recreation” in the state’s standards. The segment flows 100 miles through five counties with a watershed that covers nearly 1,000 square miles of the region<sup>2</sup>.

<sup>2</sup>

[https://www.tceq.texas.gov/assets/public/waterquality/swqm/asess/12twqi/2012\\_imp\\_index.pdf](https://www.tceq.texas.gov/assets/public/waterquality/swqm/asess/12twqi/2012_imp_index.pdf)

Chemicals and bacteria loads are not the only issues facing the Trinity River; litter threatens the water quality as well. Participation in the regional Reverse Litter campaign and other efforts helps the City identify threats to the Trinity River through drifting litter or deliberate illegal dumping. Education campaigns and inspections by staff emphasize the importance of protecting the Trinity throughout the watershed.

Dallas uses surface water reservoirs for its water supply, so the protection of these water bodies, including the Trinity River and its watershed, is imperative and a long-standing priority to City leaders and residents. Water conservation is discussed in the Materials Management section of this sustainability plan but the quality of the water in the watershed depends on the quantity of water in the watershed.

Between 1998 and 2010, Dallas averaged 37.6” of rain, close to the total received by Seattle, Washington of 37.7”. The difference becomes pronounced when comparing the frequency of rainfall days. Dallas averages 81 rainfall days annually while Seattle averages 149 rainfall days<sup>3</sup>. Precipitation, while comparable by amount to other “green” cities, comes infrequently to Dallas so when it falls it tends to occur suddenly and in heavy amounts. Due to the drier climate,

<sup>3</sup> <http://www.currentresults.com/Weather/US/average-annual-precipitation-by-city.php>

the summer heat, and the geological formations upon which Dallas rests, soils here tend to become harder and less absorbent. As a result, flash-flooding from heavy rains running off hard clay soils are diverted to the storm sewer system bringing with it whatever contaminants it may contact in the 1,000 square mile watershed.

Dallas also sits atop natural springs that make their way to surface waters. City leaders have made it a priority to protect these spring and their groundwater sources so as to use them wisely and keep them clean and clear.

To protect the quality of all water sources, the City has implemented several education and outreach programs.

One such program aims to protect City infrastructure and works to protect surface waters from sanitary sewer overflows (SSOs) caused by fats, oils and greases improperly disposed of through the sanitary sewer. When an SSO occurs, it damages the city infrastructure and resources are diverted from other projects to repair the damage they cause. More importantly, SSOs threaten the watershed when they erupt to the surface and impact the municipal separate storm sewer system (MS4) or, more commonly, the storm sewer system.

The City is also working through comprehensive plans, like the integrated stormwater management plan (iSWM) that encourages the application of best practices for site design to redirect rainfall and runoff to planting areas, bioswales and on-site detention or retention ponds; and cooperative agreements with regional partners aimed to educate everyone living in the watershed about the hidden threats facing our surface waters.

Yard chemicals, lawn clippings, trash, pet wastes, pesticides, industrial pollution, automobile fluids, detergents, sediment, loose soil, and other debris can result in contaminations that harm the ecological balance of the waterways and impair the water quality. In larger quantities, accumulated across the 1,000 square miles of watershed and draining into the Trinity River, obstructions can form and cause back-ups and floods that can damage or destroy nearby homes, neighborhoods and businesses.

When that happens, City resources are then diverted for avoidable damage repairs that could have otherwise been used to strengthen Dallas.

By protecting water quality, and the Trinity River watershed, from debris and contamination, the City can focus attention on building better communities and reducing environmental impacts to this vital resource.

## Goal

***The City of Dallas is working to improve water quality.***

### Objective 1

Improve water quality: the City is taking steps to restore the Trinity River to a more natural state to mitigate and minimize impacts.

#### Strategy:

Recreating the natural meander of the river and restoring wetlands will slow the flow of the Trinity River, allow for settling of suspended solids and filtration of chemicals through biological means.

Restoring creeks in the watershed to their natural state to allow for natural and biological processes to filter the waters delivered to the Trinity River.

#### Target:

Commencement of the Trinity River relocation in the Dallas Floodway to create a more natural channel by end of 2014 (TWM, Balanced Vision Plan).

Look for day lighting opportunities (TWM, Strategic Plan, CHE 8).

### Objective 2

Improve water quality: utilize strategies and policies to protect the Trinity River watershed from discharges that can threaten water quality.



**Strategy:**

Implement integrated pest management (IPM) practices reduce the frequency and quantity of pesticide applications at City facilities.

Continue compliance inspections.

**Target:**

Implement IPM for City facilities by September 2014 (TWM, EMS O&T 01097).

Reduce pollutant load at McCommas Bluff Landfill by 5% from 2007 baseline by September 2014 (SAN, EMS O&T 00986).

**Objective 3**

Improve water quality: minimize threats to the watershed through outreach and education programs to inform and engage the public in local and regional efforts.

**Strategy:**

Continue Cease the Grease education and outreach campaign and pipe clean outs.

Provide outreach and training on the protection of the watershed through the Office of Environmental Quality as part of the Environmental Management System and GreenDallas.

**Target:**

Continuation of the Cease the Grease program and cleaning of 36% of city's sanitary sewer lines by October 2014 (DWU, Performancesoft Measure).

Delivery of 72 outreach presentations on reducing pollution by OEQ through September 2014 (OEQ, Performancesoft Measure).



**WATER QUALITY SUMMARY OF OBJECTIVES**

**WATER QUALITY GOAL:  
IMPROVE WATER QUALITY**

**Objective: 1. Trinity River preservation**

Strategy	Target	Results
<ul style="list-style-type: none"> <li>Restore natural contour of River to allow for filtration.</li> </ul>	<ul style="list-style-type: none"> <li>Commencement of the Trinity River relocation in the Dallas Floodway to create a more natural channel (TWM, Balanced Vision Plan).</li> </ul>	<ul style="list-style-type: none"> <li>Dallas Floodway environmental impact study anticipated to be complete in spring 2015, providing opportunity for the Corps to begin design efforts for river relocation, dependent upon federal funding.</li> </ul>
<ul style="list-style-type: none"> <li>Restore creeks to natural state.</li> </ul>	<ul style="list-style-type: none"> <li>Look for day lighting opportunities (TWM, Strategic Plan, CHE 8).</li> </ul>	<ul style="list-style-type: none"> <li>Consultant’s investigation of Mill Creek complete. Work underway to preserve Big Spring. Anticipate Landmark Commission and Council action to be requested by early summer 2015.</li> </ul>

**Objective: 2. Protect surface waters**

Strategy	Target	Results
<ul style="list-style-type: none"> <li>Implement integrated pest management (IPM).</li> </ul>	<ul style="list-style-type: none"> <li>Development of IPM for City facilities by September 2014 (TWM, EMS O&amp;T 01097).</li> </ul>	<ul style="list-style-type: none"> <li>The IPM Administrative Directive Plan has been updated by TAMU Extension Service. Review is scheduled for October 2014 by affected city departments with a target to present to Council by the end of calendar 2014.</li> </ul>
<ul style="list-style-type: none"> <li>Inspect for compliance and enforce existing regulations that protect the Trinity River watershed.</li> </ul>	<ul style="list-style-type: none"> <li>Reduce pollutant load at McCommas Bluff Landfill by 5% from 2007 baseline by September 2014 (SAN, EMS O&amp;T 00986).</li> </ul>	<ul style="list-style-type: none"> <li>As of 2013, decrease of 11.5% for Total Suspended Solids (TSS) and a 9.5% decrease for Iron versus 2007 baseline. As of July 2014, decrease of 13.91% for TSS and 12.72% for Iron versus 2007 baseline.</li> </ul>

**Objective: 3. Education and outreach**

Strategy	Target	Results																											
<ul style="list-style-type: none"> <li>Continue education and outreach, and associated line cleanings, to reduce sanitary sewer overflows.</li> </ul>	<ul style="list-style-type: none"> <li>Continuation of the Cease the Grease program and completion of the cleaning of 36% of city’s sanitary sewer lines by October 2014 (DWU, Performancesoft Measure).</li> </ul>	<ul style="list-style-type: none"> <li>The Cease the Grease program is ongoing. There were 307 outreach events that took place in FY13-14.                             <table border="1" data-bbox="829 1451 1552 1530"> <thead> <tr> <th colspan="9">Number of Fats, Oils, Greases (FOG) related Sanitary Sewer Overflows by year</th> </tr> <tr> <th>FY05-06</th> <th>FY06-07</th> <th>FY07-08</th> <th>FY08-09</th> <th>FY09-10</th> <th>FY10-11</th> <th>FY11-12</th> <th>FY12-13</th> <th>FY13-14</th> </tr> </thead> <tbody> <tr> <td>112</td> <td>42</td> <td>39</td> <td>15</td> <td>8</td> <td>2</td> <td>3</td> <td>6</td> <td>1</td> </tr> </tbody> </table> </li> <li>In FY11-12, 1,792 miles or 44.6% of sanitary sewer cleaned. In FY12-13, 1,549 miles or 38.6% of sanitary sewer cleaned. In FY13-14, 1,557 miles or 38.8% of sanitary sewer cleaned.</li> </ul>	Number of Fats, Oils, Greases (FOG) related Sanitary Sewer Overflows by year									FY05-06	FY06-07	FY07-08	FY08-09	FY09-10	FY10-11	FY11-12	FY12-13	FY13-14	112	42	39	15	8	2	3	6	1
Number of Fats, Oils, Greases (FOG) related Sanitary Sewer Overflows by year																													
FY05-06	FY06-07	FY07-08	FY08-09	FY09-10	FY10-11	FY11-12	FY12-13	FY13-14																					
112	42	39	15	8	2	3	6	1																					
<ul style="list-style-type: none"> <li>Provide education and outreach to residents and businesses.</li> </ul>	<ul style="list-style-type: none"> <li>Delivery of 72 outreach presentations on reducing pollution by OEQ annually through September 2014 (OEQ, Performancesoft Measure).</li> </ul>	<ul style="list-style-type: none"> <li>In FY11-12, 64 event requests were received and completed. In FY12-13, 89 event requests were received and completed. In FY13-14, 83 events have been completed on the importance of environmental stewardship and sustainability.</li> </ul>																											



## Materials Management

Waste happens. Yet, much of what is no longer valued can easily be reused, repurposed or recycled; individuals simply need to overcome the natural tendency to discard what is no longer needed and participate in the proper management of wastes, regardless of their source or nature, to reduce the impacts associated with waste.

At the same time, the creation of new items from virgin materials comes at a cost difficult to truly realize. What is more valuable: a mountain or the ore it contains? The lumber of a forest or the air it purifies? A lush, grassy lawn or drinking water? Consumers should also consider how much of the virgin material went into the product versus the amount that was trimmed away and disposed, and how much material was used just for packaging the items.

Since the dawn of the industrial revolution, the industrialized nations have evolved from a locality-based sustenance economy to a market economy that relies on the consumption choices of the individual to drive economies. As a result, people now “shop ‘til they drop” and fill their homes, garages and self-storage units with items that eventually end up in the trash or storage indefinitely. The supply of materials from which these goods are fashioned is finite. The space in which these goods are stored is finite. The disposal site to which these goods are relegated at the end of their lives is finite. This model is

unsustainable. Fortunately, the market economy responds to individual choices. As consumers, individuals can drive the market toward items that are more environmentally friendly to produce, transport, use and dispose.

The City is already working to reduce its impacts through EMS commitments; collaborations with the Texas Product Stewardship Council to help raise awareness about end of life options for hard to recycle products and enhanced producer responsibility; litter reduction strategies and policies; and, investigating long-range waste management to reduce materials going to landfill. These strategies aim to complement other efforts in place in the City to help guide consumers and provide them with more options to reduce their environmental footprint.

Another material resource to consider is water. Water is vital for life. The City has multiple plans in place to explore, procure and develop future sources of water. As mentioned in the Water Quality section of this plan, the City uses surface waters for drinking water supplies. It is also the same source for the water applied to lawns, to flush wastes and as a resource in industrial applications.

The City is reducing the amount of water it uses at City facilities. As part of the effort to build green, new facilities have water saving measures in place like low-flow toilets, rainwater harvesting, and drip irrigation to reduce use. As

part of the EMS, City departments commit to reducing overall water usage by 5% annually; City golf courses are being watered with highly treated wastewater effluent to save billions of gallons of water annually; and, Dallas Water Utilities has a dedicated team to provide outreach and education on the importance of water conservation privately and commercially to ensure everyone living in Dallas has access to clean, clear sustaining water.

As with all things, there are multiple considerations which influence decisions people make. Strengthening the environmentally preferred or green purchasing policy to cover all City functions and all City staff from City Council to third-party contractors will help further reduce the City's footprint.

While it is important to work toward the protection of the environment through materials management, it is also important to not allow *perfect* to become the enemy of *good*. In other words, if the technology or practices available today are better than what was available yesterday but not as good as what will be available tomorrow, one should not dismiss the improvement or depreciate its value and remain steadfastly locked in the past or married to old technology while waiting for the *next* “next best thing”.

## Goal

***The City of Dallas is working to protect natural resources through better materials management.***

### Objective 1

Better materials management: increase “household” recycling, which aids in moving items away from the waste stream and back into the production cycle.

#### Strategy:

Increase household recycling rates citywide.

Increase recycling rates at City facilities.

#### Target:

Increase household participation recycling rate from 73% to 74% (SAN, Strategic Plan, CHE 5).

Increase in tons recycled by 30% over FY09-10 totals by September 2013 (SAN, EMS O&T 01022).

Increase in the percentage of solid waste that is recycled by 5% per year at Love Field through 2014 (AVI, EMS O&T 00706).

Increase in the paper recycling by 3% annually at Detention Center by September 2014 (CDS-DMO, EMS O&T 01025).

Increase in the paper recycling by 2% over the FY11-12 baseline through September 2014 (DPD, EMS O&T 01045).

### Objective 2

Better materials management: encourage the proper management of process wastes to divert these materials from landfilling.

#### Strategy:

Implement strategies and programs to increase recycling of process wastes to help minimize the footprint associated with providing services.

#### Target:

Increase scrap metal recycling by 10% of FY11-12 baseline annually by September 30, 2017 (DWU, EMS O&T 01027).

Increase in the amount of beneficial re-use items diverted from the landfill by 3% over FY08-09 baseline by September 2012 (SAN, EMS O&T 00989).

### Objective 3

Better materials management: reduce the impacts of hazardous materials on the ecosystem through collection events.

#### Strategy:

Continued participation in the Dallas County inter-local agreement for household hazardous waste collection, and the hosting of hazardous

waste roundups, will provide options for the disposal of hazardous materials.

**Target:**

Completion of two household hazardous waste collection events annually (SAN, Strategic Plan, CHE 5).

### Objective 4

Better materials management: saving water through conservation programs and infrastructure inspections.

**Strategy:**

Reduce average consumption.

Inspections of water mains for leaks will reduce the amount of water loss in the potable system.

Increase the amount of highly treated wastewater effluent available for reuse.

**Target:**

Completion of 45 audits and issuance of up to \$2 million in incentives annually for Dallas Water Utilities customers under the industrial, commercial and institutional incentive program (DWU, Strategic Plan, CHE 5).

Reduction in the average gallons per capita per day (gpcd) demand by 1.5% over FY10-11 by September 2015 (DWU, EMS O&T 01028).

Inspection of 2,500 miles of water main line annually for leaks (DWU, EMS O&T 00537).

Increase in amount of highly treated wastewater effluent reused per day by 5 million gallons by September 2014 (DWU, EMS O&T 01006).

### Objective 5

Better materials management: greener purchasing reduces environmental footprints.

**Strategy:**

Increasing the purchase of products with a smaller environmental footprint helps the City reduce its environmental footprint. Buy green to minimize resource impacts.

**Target:**

Increase in the number of less toxic chemicals available through the Product Substitution Program by 4% by September 2014 (EBS, EMS O&T 01031).

Develop and implement a fuel conservation program by September 2014 (EBS, EMS O&T 01052).

Implement a Product Substitution Program to reduce purchase of toxic chemicals by 25% annually by September 2016 (CIS, EMS O&T 01100).





**MATERIALS MANAGEMENT SUMMARY OF OBJECTIVES**

**MATERIALS MANAGEMENT GOAL:  
BETTER MATERIALS MANAGEMENT**

**Objective: I. Increase “household” recycling**

Strategy	Target	Results
<ul style="list-style-type: none"> <li>Increase household recycling rates citywide.</li> </ul>	<ul style="list-style-type: none"> <li>Increase the residential recycling participation rate from 73% to 74% (SAN, Strategic Plan, CHE 5).</li> </ul>	<ul style="list-style-type: none"> <li>The baseline was Q4 of FY11-12 where the rate was 70.4%. (EMS O&amp;T 01056).</li> <li>Residential recycling participation rate is currently at 75.1%.</li> </ul>
	<ul style="list-style-type: none"> <li>Increase in the tons recycled by 30% over FY09-10 totals by September 2013 (SAN, EMS O&amp;T 01022).</li> </ul>	<ul style="list-style-type: none"> <li>FY09-10 total tonnage recycled: 45,152 tons. In FY10-11, the total tonnage recycled: 48,983. In FY11-12, the total tonnage recycled: 51,300. In FY12-13, the total tonnage recycled: 53,280. In FY13-14, the total tonnage recycled: 53,638.</li> <li>Progress made over FY09-10: 18.8%. Sanitation has increased social media outreach and is targeting areas with low participation to increase the recycling tonnage. They are also expanding outreach to multi-family residents and promoting the community container program.</li> </ul>
<ul style="list-style-type: none"> <li>Increase recycling rates at City facilities.</li> </ul>	<ul style="list-style-type: none"> <li>Increase in the percentage of solid waste that is recycled by 5% per year at Love Field through 2014 (AVI, EMS O&amp;T 00706).</li> </ul>	<ul style="list-style-type: none"> <li>Love Field continues to promote recycling in the terminal and has identified practices to increase recycling volume in staff areas. New contract terms with waste haulers will require monthly volume and weight reports for Love Field. With the modernization project completing, a new baseline number will be established to be used going forward to capture realized results.</li> </ul>
	<ul style="list-style-type: none"> <li>Increase in paper recycling by 3% annually at Detention Center by September 2014 (DMO, EMS O&amp;T 01025).</li> </ul>	<ul style="list-style-type: none"> <li>In FY11-12, 2,195 pounds of paper collected and recycled. In FY12-13, 2,901 pounds of paper collected and recycled. In FY13-14, 3,320 pounds of paper collected and recycled.</li> </ul>
	<ul style="list-style-type: none"> <li>Increase in the recycling throughout DPD by 2% over the baseline year FY11-12 through September 2014 (DPD, EMS O&amp;T 01045).</li> </ul>	<ul style="list-style-type: none"> <li>DPD recycling has increased due to increased employee involvement. DPD established a baseline of 86,205 pounds. In FY11-12, DPD recycled 120,210 pounds. In FY12-13, DPD recycled 172,870 pounds.* In FY13-14, DPD recycled 137,750 pounds.</li> </ul>

\*Includes one-time housekeeping of scrap metal bullet casings from gun range.

<b>Objective: 2. Process waste management</b>		
Strategy	Target	Results
<ul style="list-style-type: none"> <li>Implement process waste minimization programs.</li> </ul>	<ul style="list-style-type: none"> <li>Increase scrap metal recycling by 10% of FY11-12 baseline annually by September 2017 (DWU, EMS O&amp;T 01027).</li> </ul>	<ul style="list-style-type: none"> <li>In FY11-12, DWU recycled 669,320 pounds of scrap metal. In FY12-13, DWU recycled 926,920 pounds of scrap metal. In FY13-14, DWU recycled 1,097,840 pounds of scrap metal.</li> </ul>
	<ul style="list-style-type: none"> <li>Increase in the amount of beneficial re-use items diverted from the landfill by 3% over FY08-09 baseline by September 2012 (SAN, EMS O&amp;T 00989).</li> </ul>	<ul style="list-style-type: none"> <li>The following items were reused: In FY11-12, asphalt, 6,987 tons; concrete, 9,097 tons; glass 3,496 tons; and, sawdust 983 tons. In FY12-13, asphalt, 19,362 tons; concrete, 10,831 tons; glass, 2,633 tons; and, sawdust, 2,118 tons. In FY13-14, asphalt, 25,655 tons; concrete, 30,548 tons; glass, 5,483 tons; 200% increase in diversion over baseline of 20,559 tons.</li> </ul>
<b>Objective: 3. Hazardous waste management</b>		
Strategy	Target	Results
<ul style="list-style-type: none"> <li>Reduce hazardous waste impacts to the environment.</li> </ul>	<ul style="list-style-type: none"> <li>Completion of two household hazardous waste collection events annually (SAN, Strategic Plan, CHE 5).</li> </ul>	<ul style="list-style-type: none"> <li>In FY11-12, COD participated in 5 collection events. In FY12-13, COD participated in 3 collection events and 2 batteries, oils, paints, &amp; antifreeze (BOPA) collections. In FY13-14, COD participated in 2 collection events and 9 BOPA collections.</li> </ul>
<b>Objective: 4. Conserve water</b>		
Strategy	Target	Results
<ul style="list-style-type: none"> <li>Reduce average consumption.</li> </ul>	<ul style="list-style-type: none"> <li>Completion of 45 audits and issuance of incentives for DWU customers under the industrial, commercial and institutional incentive program (DWU, Strategic Plan, CHE 5).</li> </ul>	<ul style="list-style-type: none"> <li>In FY13-14, 47 audits were conducted. One application was submitted and approved for \$17,000.00 to Texas Instruments. Funds will be issued when water savings project has been completed.</li> </ul>
	<ul style="list-style-type: none"> <li>Reduction in the average gallons per capita per day (gpcd) demand by 1.5% over FY10-11 by September 2015 (DWU, EMS O&amp;T 01028).</li> </ul>	<ul style="list-style-type: none"> <li>5 year average is 199 gpcd.</li> <li>FY12-13: 187 gpcd realized.</li> <li>FY13-14: 182 gpcd realized; a reduction of 2.7%.</li> </ul>
<ul style="list-style-type: none"> <li>Reduce water waste through inspection of mains.</li> </ul>	<ul style="list-style-type: none"> <li>Inspection of 2,500 miles of water main line annually for leaks (DWU, EMS O&amp;T 00537).</li> </ul>	<ul style="list-style-type: none"> <li>In FY11-12, 3,729 miles of main inspected. In FY12-13, 4,315 miles of main inspected; 440 leaks found. In FY13-14, 4,691 miles of main inspected; 308 leaks found.</li> </ul>
<ul style="list-style-type: none"> <li>Use highly treated effluent for reuse.</li> </ul>	<ul style="list-style-type: none"> <li>Increase in the amount of highly treated wastewater effluent reused per day by 5 million gallons by September 2014 (DWU, EMS O&amp;T 01006).</li> </ul>	<ul style="list-style-type: none"> <li>In FY10-11, 84,784,700 gallons reused. In FY11-12, 60,219,300 gallons reused; MGD=0.164984. In FY12-13, 55,562,000 gallons reused; MGD=0.152225. In FY13-14, 36,173,000 gallons reused; MGD=0.099104.</li> </ul>

Objective: 5. Green purchasing		
Strategy	Target	Results
<ul style="list-style-type: none"> <li>Buy green to minimize resource impacts.</li> </ul>	<ul style="list-style-type: none"> <li>Increase in the number of less toxic chemicals available through the Product Substitution Program by 4% by September 2014 (EBS, EMS O&amp;T 01031).</li> </ul>	<ul style="list-style-type: none"> <li>The Green Procurement Approved List has increased to 373 items approved for purchase. This is a 13.5% increase over the FY09-10 baseline.</li> <li>EBS held a Green Procurement Committee meeting in July 2014 to discuss green procurement activities with EBS, DFR, DPD, STS, TWM, and SAN to help reduce the use of hazardous chemicals at City facilities.</li> </ul>
	<ul style="list-style-type: none"> <li>Develop and implement a fuel conservation program by September 2014 (EBS, EMS O&amp;T 01052).</li> </ul>	<ul style="list-style-type: none"> <li>FY10-11 baseline: 7,126,723 gallons. In FY11-12, 6,630,024 gal used – 6.97% reduction v FY10-11. In FY12-13, 6,905,499 gal used – 3.11% reduction v FY10-11. In FY13-14, a 4.3% reduction realized v FY10-11.</li> </ul>
	<ul style="list-style-type: none"> <li>Implement a Product Substitution Program to reduce toxic chemicals by 25% annually by September 2016 (CIS, EMS O&amp;T 01100).</li> </ul>	<ul style="list-style-type: none"> <li>CIS maintains 36 chemicals in inventory; 14 chemicals have been designated as replaceable or no longer needed. With the use and/or disposal of these 14 items, projection is 42% of chemicals will be replaced with less toxic products.</li> </ul>



## Energy Management

Dallas, once an oil-boom town, has long been associated with energy and today stands ready to explore and embrace new energy technologies to decrease consumption of carbon-based fuels and grid dependence.

As anyone living in North Texas can attest, Dallas is blessed with an abundance of sunlight. The advancement and incorporation of solar energy production into the infrastructure and on buildings in Dallas is logical, progressive and frees up financial resources for use on other infrastructure and social needs. While the Dallas-Fort Worth region does not fall into the ideal wind-generating zone, Texas, remains firmly the largest producer of wind energy in the United States<sup>4</sup>. Large scale applications may currently be unattainable in Dallas, but small scale, individual unit applications are being realized and placed throughout the city.

But power generation is only one component of freeing Dallas and all of North Texas from the shackles of carbon-based energy. The region continues to grow more populated meaning an increase in demand, cost fluctuations, and resource competition. To shield consumers from the volatility of the energy markets, conservation measures reduce what is obtained from conventional sources until such a time when local solar and wind based production methods exceed consumption.

While Dallas stands to benefit from cheap, local energy from solar and wind technologies over the coming years, the separation from carbon-based fuels will reduce grid load and the associated environmental impacts by reducing the amount of air polluting emissions released from conventional coal or gas powered electric plants.

Dallas is on the leading edge of cities in America buying and producing renewable energy. These commitments keep Dallas eligible for federal and state dollars offered to cities moving toward energy independence and a more sustainable way of life.



<sup>4</sup>

[http://apps2.eere.energy.gov/wind/windexchange/wind\\_installed\\_capacity.asp](http://apps2.eere.energy.gov/wind/windexchange/wind_installed_capacity.asp)

## Goal

**The City of Dallas is working to reduce the consumption of energy from non-renewable sources and expand the availability of renewable energy.**

### Objective 1

Reduce non-renewable energy use, expand availability of renewable: purchasing alternative energy removes the environmental impacts to air associated with energy production and safeguards against market volatility.

#### Strategy:

The City of Dallas will continue in its negotiated energy contract to buy renewable energy credits that will allow for further investment in alternative energy.

At the end of this contract term, the City will continue to purchase renewable energy.

#### Target:

Purchase of at least 50% of the City's energy from renewable energy sources (PBW, Strategic Plan, CHE 4).

### Objective 2

Reduce non-renewable energy use, expand availability of renewable: reduce consumption to minimize the impacts from traditional energy production methods.

#### Strategy:

Maintain conservation efforts internally as part of the EMS to continue reducing City demand on the grid by 5% annually.

In addition, the City will continue to pursue performance contracting to fund refits to existing building stock and minimize demand to reduce the amount of energy needed to power facilities.

#### Target:

Reduction in average electric energy use per million gallons treated at wastewater treatment plants from FY08-09 baseline by December 2013 (DWU, EMS O&T 01029).

Reduce monthly electrical demand and peak hour charges of ERCOT load during 4-CP (4-Coincident Peaks)<sup>5</sup> months (June-September) by October 2014 (DWU, EMS O&T 01068).

Replace street light bulbs with energy efficient LED lights by December 2014 (STS, EMS O&T 01091).

### Objective 3

Reduce non-renewable energy use, expand availability of renewable: explore and pursue the installation of alternative energy power sources at City facilities on a case by case basis.

#### Strategy:

Conduct feasibility research and develop a plan to generate energy at City facilities.

Explore the construction of solar installations.

#### Target:

Development of an on-site energy production plan by October 2014 (PBW, Strategic Plan, CHE 4).

Determination of the feasibility for solar installations by February 2015 (PBW, Strategic Plan, CHE 4).

<sup>5</sup> Average 4-CP is defined as "the average Settlement Interval coincidental MW peak occurring during the months of June, July, August, and September." [www.ercot.com](http://www.ercot.com)



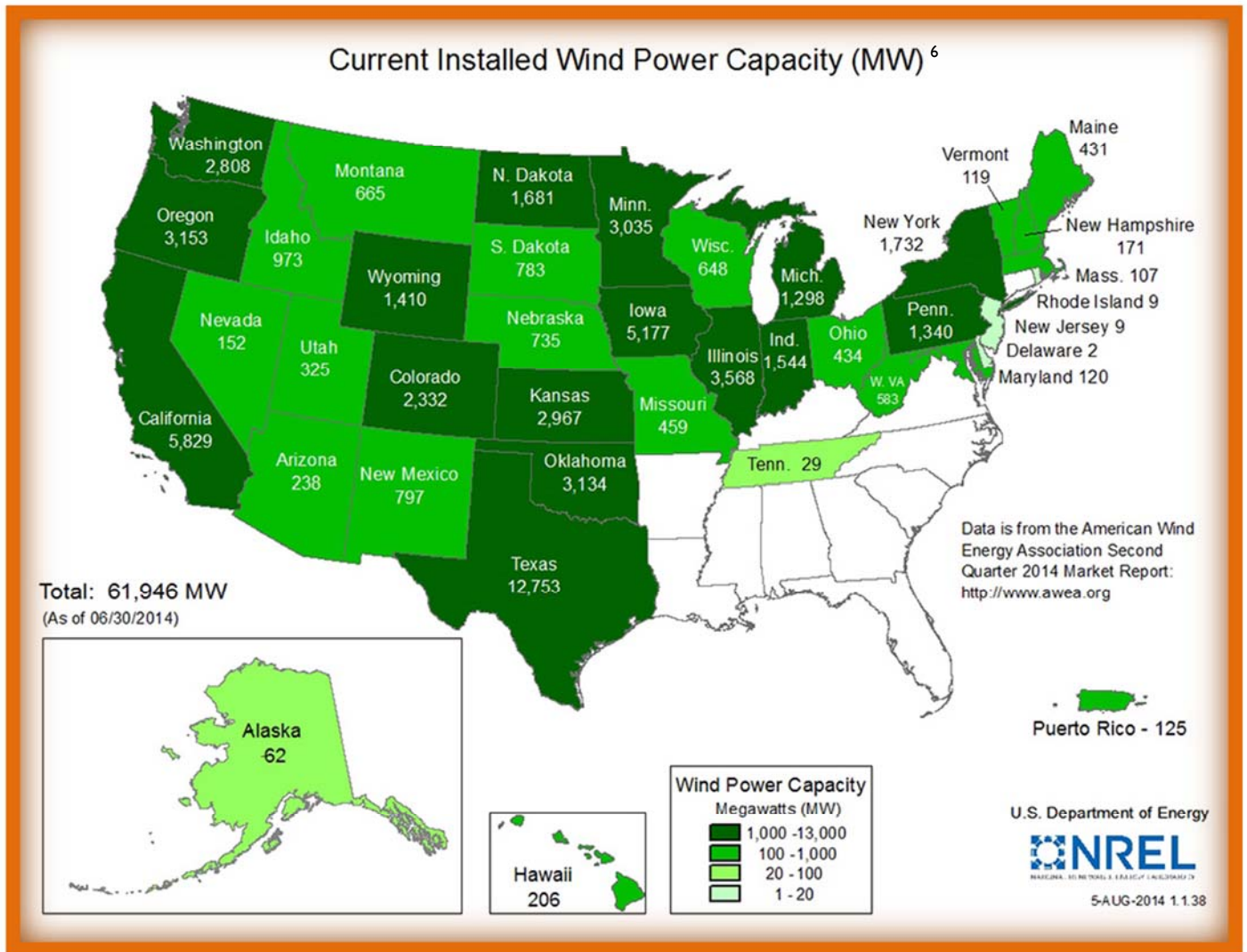

6

[http://apps2.eere.energy.gov/wind/windexchange/wind\\_installed\\_capacity.asp](http://apps2.eere.energy.gov/wind/windexchange/wind_installed_capacity.asp)

**ENERGY MANAGEMENT SUMMARY OF OBJECTIVES**

**ENERGY MANAGEMENT GOAL:  
REDUCE NON-RENEWABLE ENERGY USE, EXPAND AVAILABILITY OF RENEWABLE**

**Objective: 1. Purchase green energy**

Strategy	Target	Results
<ul style="list-style-type: none"> <li>Continue purchasing renewable energy.</li> </ul>	<ul style="list-style-type: none"> <li>Purchase of at least 50% of the City’s energy from renewable energy sources (PBW, Strategic Plan, CHE 4).</li> </ul>	<ul style="list-style-type: none"> <li>City has purchased 50% renewable energy for contract years 2014, 2015, 2016 under Renewable Energy Program.</li> <li>Estimates project this purchase will reduce the City GHG emissions by over 270,000 tons of CO2e per year.</li> <li>City of Dallas is number 4 in top 30 Local Government on EPA Green Power Partnership.</li> </ul>

**Objective: 2. Energy conservation**

Strategy	Target	Results
<ul style="list-style-type: none"> <li>Maintain EMS conservation efforts to achieve a 5% reduction in City usage annually.</li> </ul>	<ul style="list-style-type: none"> <li>Reduction in average electric energy use per million gallons treated at wastewater treatment plants from FY08-09 baseline by December 2013 (DWU, EMS O&amp;T 01029).</li> </ul>	<ul style="list-style-type: none"> <li>FY08-09: average electric use: 1,671 kWh/Mgallons.</li> <li>FY09-10: average electric use: 1,663 kWh/Mgallons.</li> <li>FY10-11: average electric use: 1,802 kWh/Mgallons.</li> <li>FY11-12: average electric use: 2,792 kWh/Mgallons.</li> <li>FY12-13: average electric use: 2,222 kWh/Mgallons.</li> <li>FY13-14: average electric use: 2,281 kWh/Mgallons.</li> </ul>
	<ul style="list-style-type: none"> <li>Reduce monthly electrical demand and peak hour charges of ERCOT load during 4-CP (4-Coincident Peaks) months (June-September) by October 2014 (DWU, EMS O&amp;T 01068).</li> </ul>	<ul style="list-style-type: none"> <li>2011 baseline is 30,126 KWD.</li> <li>During 2012 season, 20,712 kWD used.</li> <li>During 2013 season, 22,105 kWD used.</li> <li>During 2014 season, 11,015 kWD estimated use.</li> </ul>
	<ul style="list-style-type: none"> <li>Replace traffic light bulbs with energy efficient LED lights by December 2014 (STS, EMS O&amp;T 01091).</li> </ul>	<ul style="list-style-type: none"> <li>2,453 incandescent traffic light bulbs have been replaced with energy efficient LED light bulbs between October 2013 and June 2014.</li> <li>LED lights use between 70% to 90% less energy; retrofits for FY13-14 are estimated to save \$100,000/year in electricity costs.</li> </ul>

Objective: 3. Produce energy on-site		
Strategy	Target	Results
<ul style="list-style-type: none"> <li>Conduct feasibility research and develop a plan to generate energy at City facilities.</li> <li>Explore the construction of solar installations.</li> </ul>	<ul style="list-style-type: none"> <li>Development of an on-site energy production plan by February 2015 (PBW, Strategic Plan, CHE 4).</li> </ul>	<ul style="list-style-type: none"> <li>PBW is working with Pepco Energy Services to develop a citywide Energy Management Plan, including solar and other onsite energy production.</li> </ul>
	<ul style="list-style-type: none"> <li>Determination of the feasibility for solar installations by February 2015 (PBW, Strategic Plan, CHE 4).</li> </ul>	<ul style="list-style-type: none"> <li>Three PV projects were combined into the Convention Center Solar Project. Installations at City Hall, Jack Evans Police Headquarters, and Convention Center have been designed. The City received SECO loan funding and approval of the ONCOR rebate application. However, the project is not financially feasible without additional funding. PBW is still exploring options.</li> <li>PBW initiated solar procurement at SSWWTP and continues to develop more projects where they are economically feasible. Currently evaluating a project for solar at the Morton H. Meyerson Symphony Center.</li> </ul>



## Conclusion

Sustainability is an important priority in the City's plans for the present and the future. Dallas has acted to support sustainability for some time. These actions are condensed in this sustainability plan into five broad goals:

- Improve air quality;
- Promote smart growth and development;
- Improve water quality;
- Better materials management; and,
- Reduce non-renewable energy use.

As support for these goals, the City has in place eighteen objectives built upon thirty strategies for achievement. Finally, the strategies are actualized as the City progresses toward achieving forty-three specific performance targets. Successful completion of the tasks in this first sustainability plan is reflective of the City Council's determination to grow the City while preserving the environment.

Over time, this plan will evolve. With each achievement, the plan will build on those successes. Each time, the City will need to redefine performance targets by determining not only what will be done but also by when and to what extent. Over the life of the plan, the Office of Environmental Quality will provide annual updates and revisions to capture, track and report progress.

Each version will be a starting point, a means and not an end, for advancing sustainability. There will be new inspiration and action incorporated into this plan as Dallas grows and learns. And, the journey continues...

# Appendices



## Green Your Life: City of Dallas Programs

The City of Dallas supports multiple programs to help residents and businesses protect the environment and save money.

More information on these programs can be found online or through [GreenDallas.net](http://GreenDallas.net).

### AirCheck Texas Drive a Clean Machine Program

A state funded program operated by the North Central Texas Council of Governments for persons living in the nine-county DFW region. The City of Dallas supports this program by advertising and helping to answer questions about application requirements. For more information, visit [www.DriveACleanMachine.org](http://www.DriveACleanMachine.org) or call 214-670-3887.

### Cease the Grease

Did you know that pouring fats, oils, or grease (FOG) down your kitchen sink drain can clog your pipes, or even the sanitary sewer lines? Prevent this by storing fats, oils, or grease in a container, then dropping it off at one of the many locations around Dallas. This not only keeps your drains clear, but the City of Dallas can convert FOG's to energy. Visit [www.CeaseTheGrease.org](http://www.CeaseTheGrease.org) for more information.

### Hospitality Industry Program

Over the next several years, City of Dallas Water Utilities (DWU) will partner with Dallas hotels/motels and restaurants to encourage them to continue, and in some cases, expand their efforts to conserve water. The program will be voluntary and will not be regulated by the City of Dallas. The initiative is supported by the Hotel Association of North Texas, the Greater Dallas Restaurant Association, Downtown Dallas Inc., the Dallas Convention and Visitors Bureau, Tarrant Regional Water District and North Texas Municipal Water District. For more information on the Hospitality Industry Program, please visit [www.SaveDallasWater.com](http://www.SaveDallasWater.com) or call Terry Lowery at 214-670-4685.

### Irrigation Check-ups

Dallas Water Utilities conducts free automatic irrigation system check-ups to make sure that your system is operating properly and that watering schedules are appropriate for your yard's needs. To sign up for an appointment or get more information, go to [www.SaveDallasWater.com](http://www.SaveDallasWater.com).

### Minor Plumbing Repair Program

This program offers assistance with minor plumbing problems and fixtures that may cause water waste and higher water bills. [Click here to apply](#) or visit [www.SaveDallasWater.com](http://www.SaveDallasWater.com) for more information.

### New Throne for Your Home Toilet Voucher

Dallas Water Utilities offers up to \$90 per toilet to replace existing high-flow toilets (generally those installed before 1992) with low-flow or high-efficiency toilet models. A newer model could save more than 60 percent of water per flush, and save you money. For more information visit [www.SaveDallasWater.com](http://www.SaveDallasWater.com). To apply for a rebate, [click here](#) (purchase already made). To apply for a voucher, [click here](#) (for future purchase).

### Texas Emissions Reduction Plan (TERP) Grant Program

The State of Texas is providing financial assistance to those who own/operate heavy-duty diesel vehicles or equipment, i.e. semi-trucks, construction equipment, in order to improve air quality. Funding opportunities are offered once or twice each year. The City of Dallas is available to assist you through the application process. For more information about TERP visit [www.TerpGrants.org](http://www.TerpGrants.org) or call 214-670-3887.

## Green Your Life: Tips & Tools

There are many ways you can reduce your environmental footprint at home or work. When you do, you're not only saving natural resources by using less, you're also reducing emissions that impact our air quality and our water quality.

Below, we list some of the more popular suggestions. For a more in depth look, visit [GreenDallas.net](http://GreenDallas.net) or email us at [GreenDallas@dallascityhall.com](mailto:GreenDallas@dallascityhall.com).

### Save Energy

- **Unplug it!** Appliances and equipment that are plugged in are still sucking power even though they're off (think cell phone chargers, toasters, lamps). Turn off power strips when not in use to reduce "Vampire Power".
- **Install a programmable thermostat!** In the summer, keep your thermostat at least 78 degrees while you are at home and at least 85 degrees when gone; in the winter, try 68 when you're home and 60 when gone. Watch your energy bills drop!
- **Replace your air filter!** Just like you, the air conditioner needs to be able to move air to work best. Change your filter at least every 3 months because a blocked filter will make your system run longer causing higher energy costs and it could overwork and damage your system.
- **Seal it up!** Stop leaks and avoid intruding air. Replace weather stripping. Seal around window and door jambs. Add extra insulation in attics and in walls.
- **Turn your hot water heater down!** Adjust your heater to 110° in summer and 115° in winter. The water will still be hot but your energy bill will be much lower. And when you run the water to get it warm, capture that cool water and use it on plants outdoors in summer or save it in the washing machine for the cool water wash year round.

### Save Water

- **Turn it off!** Turn off water when brushing teeth.
- **Take shorter showers!** You'll save water and the energy used to heat it. Extra payoff: By taking shorter showers, you'll prevent 350 pounds of CO<sub>2</sub> and keep about \$100 in your pocket each year.
- **Install a low flow shower head!** There are many types of designs that put out less than 3 gallons per minute. They still have great pressure and conserve gallons of water from each shower.
- **Install an efficient toilet!** New toilets use around 1.6 gallons per flush – older models can use up to 6 gallons! That's a lot of water. [Find out if you qualify for a voucher](#) from the City of Dallas that helps homeowners and apartment managers/owners purchase water-saving low-flow toilets.
- **Wait until it's full!** Run the washing machine and dishwasher only when they're full. Depending on the age and performance level of your dishwasher, you may need to pre-rinse to remove food items that can be stuck on or are not filtered out prior to the rinse cycle to keep from having to rewash the same dish twice which costs more than a quick rinse before loading. If your dishwasher is a high performance model, the extra pay off by skipping pre-rinse is that you can reduce carbon dioxide from being released and save money each year.

### Clear the Air

- **Tune-ups and tires!** Keep your vehicle in tune, keep it inspected, and check the air pressure in your tires. An under-inflated tire will cause your vehicle to get poor gas mileage and wear down your tires faster. You'll increase the life of your vehicle, get better gas mileage, and reduce emissions by as much as half at the same time.
- **Report smoking vehicles!** Report smoking vehicles. Dial #SMOKE from your cell phone to anonymously report smoking vehicles.
- **Don't idle!** Idling your vehicle wastes fuel, creates emissions, and can be harmful to little lungs. Parents should shut down their engines while waiting for the school bell to release their little learners at the end of the day. Check out [GreenDallas.net](http://GreenDallas.net) to order a no-idling sign for your child's school. Call 1-877-NTX-IDLE to report vehicles idling for more than 5 minutes.
- **Share!** Carpool or use public transportation. Fewer vehicles on the roads mean fewer emissions. You'll save a few bucks each day in gasoline and you will not have to search for a parking space. Remember, you're not stuck in traffic, you *are* traffic.
- **Don't top off!** Topping off the tank releases gas vapors into the atmosphere which contribute to the formation of smog.
- **Wait until the evening!** Do not fuel your vehicle or mow your lawn during morning hours. Emissions released in the morning hours contribute to the formation of smog.

### Green Your Home

- **RECYCLE!** Recycle your cardboard, metal cans, plastics, and paper products. By recycling you help reduce the amount of waste going into the landfill.

- **Change a light bulb!** The Energy Independence and Security Act of 2007 established new lighting standards that require light bulbs to use 25% less energy by 2014. Three major types of bulbs meet these requirements and are available to consumers: halogen incandescent, compact fluorescent, and light emitting diode. Halogen incandescent bulbs meet the energy savings requirements by using one-fourth the energy. Compact fluorescent light, or CFL, bulbs use one-third the energy and last up to 10 times longer than incandescent bulbs. Light emitting diode, or LED, bulbs use one-fifth the energy and last up to 25 times longer than incandescent bulbs! So, replace the bulbs in the 5 most used light in your house with CFLs or LEDs and save money. Plus, the bulbs burn cooler so you will not have to overcome their heat in the summer. **The payoff:** With new EISA standards, U.S. households could save nearly \$6 billion dollars in 2015 alone.
- **Buy energy-efficient appliances!** Let's say your old fridge gives out. There is a bright side! Replace it with an [Energy Star™](#) appliance and you'll use at least 15 percent less energy and water in your home. It might be a little pricier to buy up front, but you'll be saving money on your utility bills each month. And you'll be helping the environment. **The payoff:** If we all installed one Energy Star™ appliance, it would be like planting 1.7 million acres of new trees.
- **Reduce litter!** Instead of contributing to the countless single-use bags that become loose in the environment and pollute our waterways and our communities, grab a reusable bag when you go shopping and properly recycle any single-use bags. **The payoff:** You're reducing pollution and helping improve the aesthetics of our city.
- **Cancel unsolicited mail!** Many of us have a steady flow of unwanted and unsolicited junk mail, catalogs, and magazines. Call 888-5-OPTOUT to get off the list. Also, make sure to recycle what you do receive. **The payoff:** Less energy is spent on creating paper (which kills trees we need) and less trash is created when we can reuse products. The immediate return? Less clutter at home! Long term? A cleaner planet!

### Green Your Lawn

- **Compost!** Green your garden with a compost pile. You'll save space in the landfill and in the process you'll create free, healthy fertilizer for your garden. A good compost pile consists of a balance of carbon and nitrogen materials. Carbon materials include leaves, shredded cardboard, shredded newspaper, straw, pine needles. Nitrogen materials include fresh grass clippings, kitchen scraps, manure (no cat or dog feces), coffee grounds and tea leaves. Check out [www.mastercomposter.com](http://www.mastercomposter.com) for more compost ingredients and more. The payoff:
- **Leave it there!** Instead of bagging your lawn clippings leave them on the lawn. The clippings will naturally fertilize your yard.
- **Go Native Texan!** Use native plants for landscaping. They require less water and are more tolerant to our climate.
- **Plant a tree!** The shade it provides can lower your cooling bills if it shades your roof or walls. A single tree can absorb one ton (2,000 pounds) of carbon dioxide over its lifetime. One acre of tree cover can compensate for automobile fuel use equivalent to driving a car between 7,200 and 8,700 miles.
- **Water wise!** Only water your lawn when it needs it which is about 1 inch every 7 to 10 days. Watch for signs of stress between waterings. Bermuda will turn a bluish color or leave imprints when you step on it. St. Augustine blades will begin to roll. Call 214-670-3155 or visit <https://savedallaswater.com/rebates-and-incentives/irrigation-check-ups/> to schedule a free sprinkler system inspection and find out how some Dallas residents have already saved over 29,000 gallons of water a week!

### Know Your Impact

- Find out your "carbon footprint" aka your environmental impact on the planet. We all contribute to climate change when we do things like heat and cool our homes, drive our cars, and fly on airplanes.
- Find out how to begin decreasing the energy you use each day, and offset the rest of your carbon-emitting energy use through this easy-to-use carbon calculator. Once you do, tell the planet (or at least a few friends).
- Calculate your carbon footprint: [EPA Personal Emissions Calculator](#)

## **Selected City Council Ordinances, Resolutions and Authorizations**

Tree Resolution, 90-1496

Ozone Action Plan, Council Resolution 94-2201

Tree Preservation Ordinance, Council Resolution 94-1988, Ordinance 22053

Conservation Easement Ordinance, Ordinance 25155, 24843

Water Conservation Ordinance, Council Resolution 01-2840, Ordinance 24745

Green Building Program, Council Resolution 03-0367

Office of Environmental Quality Ordinance, Council Resolution 04-0810, Ordinance 25517

Environmentally-Preferred Procurement Green Purchasing, Council Resolution 04-1722

EMS Policy, Council Resolution 05-0362

Clean Fleet Vehicle Policy 01/25/06, Resolution 06-0323

“Too Good to Throw Away”, 10/11/2006 Consent Agenda

TCEQ Sanitary Sewer Outreach Agreement, Council Resolution 07-0279

Integrated Stormwater Management, Council Resolution 08-0421

Green Building Ordinance, Phase I, Council Resolution 08-1070, Ordinance 27131

Green Building Ordinance, Phase II, Council Resolution 12-2428, Ordinance 28813

Great Trinity Forest Management Plan, Council Resolution 08-2779

Creation of Trinity Watershed Management, Council Resolution 09-2383, Ordinance 27697

Compressed Natural Gas Taxicab Ordinance, Council Resolution 10-0729, Ordinance 27831

Community Gardens Ordinance, Council Resolution 11-0434, Ordinance 28125

Green Cement Purchasing Policy, Council Resolution 11-0657

Idling Ordinance, Council Resolution 11-2976, Ordinance 28456

Neighborhood Farmers Markets, Council Resolution 10-2781, Ordinance 28046

Carryout Bag Ordinance, Council Resolution 14-0564, Ordinance 29307

## **City of Dallas Policies**

AD 2-49, “Environmental Management Systems”

AD 3-73, “Environmental Management Program”

AD 6-2, “Fleet and Equipment Utilization”

Ozone Action Plan

AD 6-15, “Inspection of City Vehicles”

## City Environmental Policy



### Environmental Policy

The City of Dallas is committed to a clean, safe, and healthy environment. As such, we will exercise environmental stewardship in our dealings with employees, other governments, citizens, City contractors, business and others in the community for our world today as well as for future generations. Caring for the environment is one of our core values, and this is demonstrated by ensuring our activities are in harmony with the natural world around us.

This commitment is embodied by the following actions:

- ❖ Implementation of programs and procedures with an intent to meet or exceed all applicable environmental laws and regulations.
- ❖ Continual improvement of our environmental performance through proactive environmental management and self-assessments and/or third-party assessments.
- ❖ Prevention of pollution at its source through implementation of best management practices and resource conservation measures to reuse, reclaim, and recycle materials we generate.
- ❖ Utilization of Environmental Management Systems, as appropriate for our operations, to provide a framework for systematically reviewing and reducing our environmental footprint.
- ❖ Employees will abide by all environmental regulations and demonstrate environmental compliance in their daily work practices.
- ❖ Educate City employees on Dallas' environmental policies and motivate and encourage employees to practice environmental stewardship by raising awareness and sensitivity to environmental issues through City policies, regulations, training, and interactive dialogue.
- ❖ Outreach to the citizens and businesses of our community by communication of this Policy and education on the importance of environmental stewardship for clean air and water and sustainable development for the City of Dallas.

Approved by Dallas City Council January 26, 2005.

Signed

  
 Mary K. Suhm  
 City Manager