

MUNGER PLACE SURVEY



HISTORIC PRESERVATION LEAGUE, INC.
*Made Possible By A Matching Grant From
The National Trust for Historic Preservation*

ENVIROTECHNICS

ARCHITECTS PLANNERS

3503 CEDAR SPRINGS DALLAS TEXAS 75219 TELEPHONE (214) 522-5610





- 1 INTRODUCTION
- 2 RECOMMENDATIONS
- 3 APPENDIX A -- AREA QUALITIES
- 4 APPENDIX B -- ARCHITECTURAL SKETCHES
- 5 APPENDIX C -- SURVEY FORMS
- 6 CREDITS

CONTENTS



I

INTRODUCTION

INTRODUCTION

The Munger Place Survey was begun by one who was interested in the area but who was, quite frankly, skeptical of the architectural quality of a district with so little apparent stylistic variety. Furthermore many of the buildings were, on casual glance, ready for the bulldozer. As the survey progressed these ideas were to change dramatically.

It is true that most of the houses have a basic style in common—a vernacular version of the early twentieth century "Prairie Style." The consistent use of this style serves, however, to give unity and cohesiveness to the neighborhood. Furthermore, to the careful observer, there is an exciting diversity in the individual touches each owner gave his home. Much of this variation comes from differing roof lines, soffit details, window details, and porches. For example, there are over thirty-two (32) different types of muntin patterns in the upper sashes of the windows, and this does not include the countless variations of leaded and stained glass. There are over twenty variations of column designs; few houses have even the same porch rail design. Chimney differences are abundant and front door variations provide much individuality. Although most show a dominant Prairie influence, many eclectic transitions are apparent: Tudor half-timbering, Queen Anne shingle patterns, Colonial Revival columns and ornaments are all common. With only slight imagination, Greek, Italian, and even Egyptian Revival details can be seen, while Chicago School Sullivanesque ornamentation adds a purely American touch. Unfortunately, all of this detail cannot be presented here (it would require a booklength publication), but selected examples are provided in the streetscape sketches (p.00) and in the typical design details (p.00).

As to my original concern that many of the houses should be destroyed, the facts, shown in the "Exterior Condition" map on p.00, indicated that 55% showed little or no deterioration, 39% were in need of some repairs, 5% were badly deteriorated and less than 1% would be teardowns. So much for the bulldozer theory.

On architectural qualities alone, the buildings were broken down into four categories as shown in the map on p.00. As might be expected, most of the houses fall in the middle group, with only 8% District Landmarks and 11% Nonrated. Sixty-six percent were "Significant", and 15% were "Significant but Much Altered."

Before the survey, most of the houses were believed to be multifamily, absentee landlord properties. This proved to be true, with 18% single family, 16% duplex, and 66% multifamily. These data, shown in the map on p.00, are of historic interest only for these percentages are changing so rapidly (mostly back to single family) that by press time they will be totally out of date.

Historically the area is as rich in the variation of its inhabitants' professions and ethnic backgrounds as it is architecturally. The survey area is a part of the original Munger Place, a 140-acre residential development created in the early years of this century by A. S. Munger and his brother, Collett H. Munger. Prospective buyers in 1901 looked at vacant lots that were raised one to four feet above front street level to "insure that the water from the alley and barns on the rear of your lot will not drain toward the front of your residence."¹ Other conveniences of the development included "bitulithic" paving, soft on horses' feet and quiet beyond expectation. Munger Place boasted more paving than the entire rest of Dallas! Water, sewage, telephone, and electric lines were installed in the alleys to "avoid disfiguring of the architecture", and "all deliveries would be from the rear." Landscaping was provided along the parkways and concrete sidewalks were installed. All the prospective buyer had to do was build his own home and, he could be assured, the Munger brothers predicted, that he would "contribute to the progress as well as beautify the entire city of Dallas."

Because each house was custom designed for its original owner, the overall area shows many architectural details that reflect the personal taste of the original Munger Place families. Intertwined in the history of each house is a rich genealogy of Dallas' early history, for in this neighborhood early Dallas' cultural, social, political, and financial elite resided and formulated the future of the city.

Although Munger Place was designed to be the "most select of the select", the overall development incorporated at least one other outstanding concept, which today is creeping back into residential planning: it offered tremendous variation in size and cost of housing, thus creating a diverse, small-town district within the larger city. This healthy heterogeneity has persisted to the present day.

Munger Place remained a highly desirable district into the 1930s but the housing shortages of World War II led to

¹Quotations are from the original Munger Place Sales Brochure.

the conversion of many of the larger homes into rooming houses. Thus began a decline and eventual deterioration which accelerated with zoning changes in the 1950s and 1960s. Many of the large houses were subdivided into apartments and, for some owners, fire took its toll. Some were bulldozed for new apartment sites or held by land speculators. This gradual decline reached its peak in the early 1970s when the area had become a classic example of inner city decay. It was this continuing destruction of a quality of life rarely found in today's newer homes and communities that finally brought about the organization of the few owner-residents left in the area. Working with the Dallas Department of Planning, the Historic Preservation League, and other groups, these residents have begun to turn the tide for the area.



2 RECOMMENDATIONS

RECOMMENDATIONS

In conclusion, it is our recommendation that the area bounded by Fitzhugh to Henderson and Junius to Reiger be designated as an Historic District. An appropriate ordinance should be drawn up with provisions to control both renovation/restoration and new construction (in this case, new construction would also include the relocating of older houses outside the immediate area onto vacant property within the designated area).



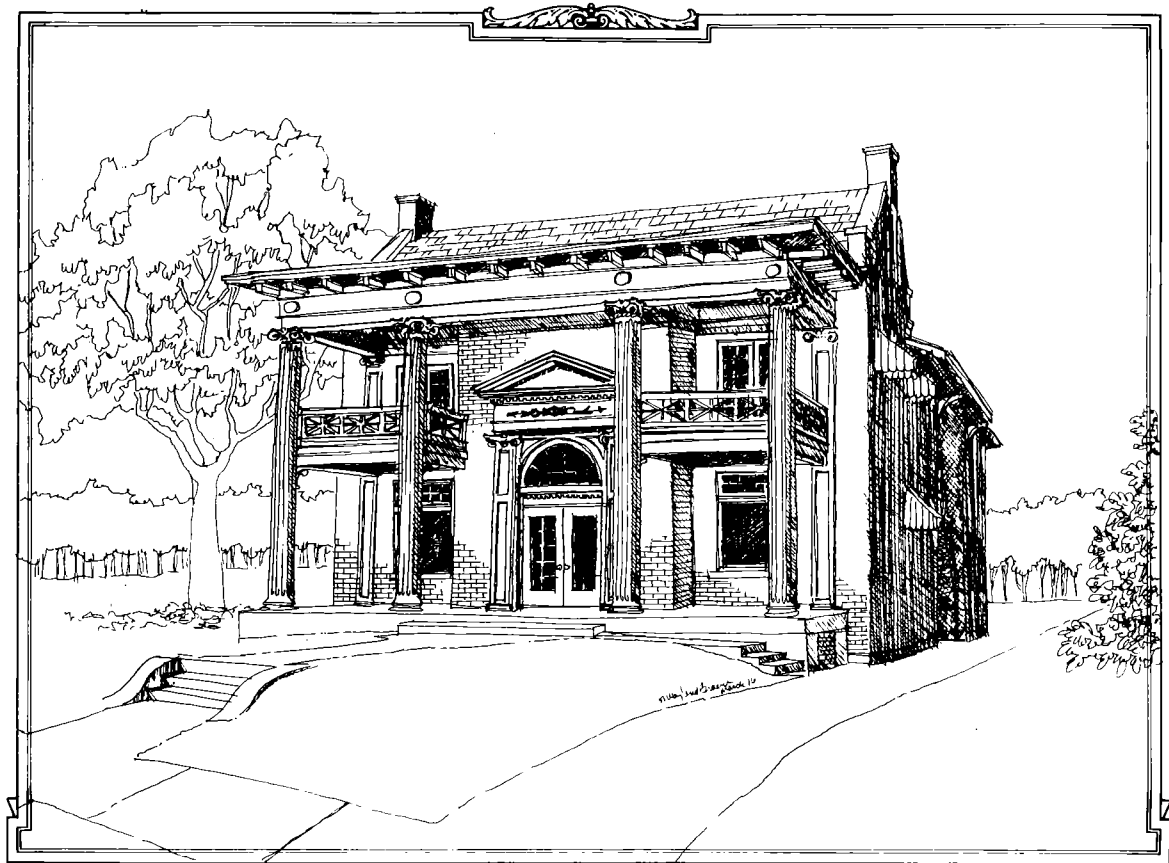

As an alternative, a Conservation District designation would be appropriate for the area. The net effect of either designation would be to stabilize the area where bankers could feel their loans would be safe; owners could be protected from undesirable encroachments; a rapidly deteriorating area of basically good housing stock can be conserved; and a neighborhood feeling can be maintained: in short, a place where the residents could be proud to live, raise a family and feel their home has provided each family member with a sense of place.

M. Wayland Brown, Architect
Envirotechnics, Architects-Planners

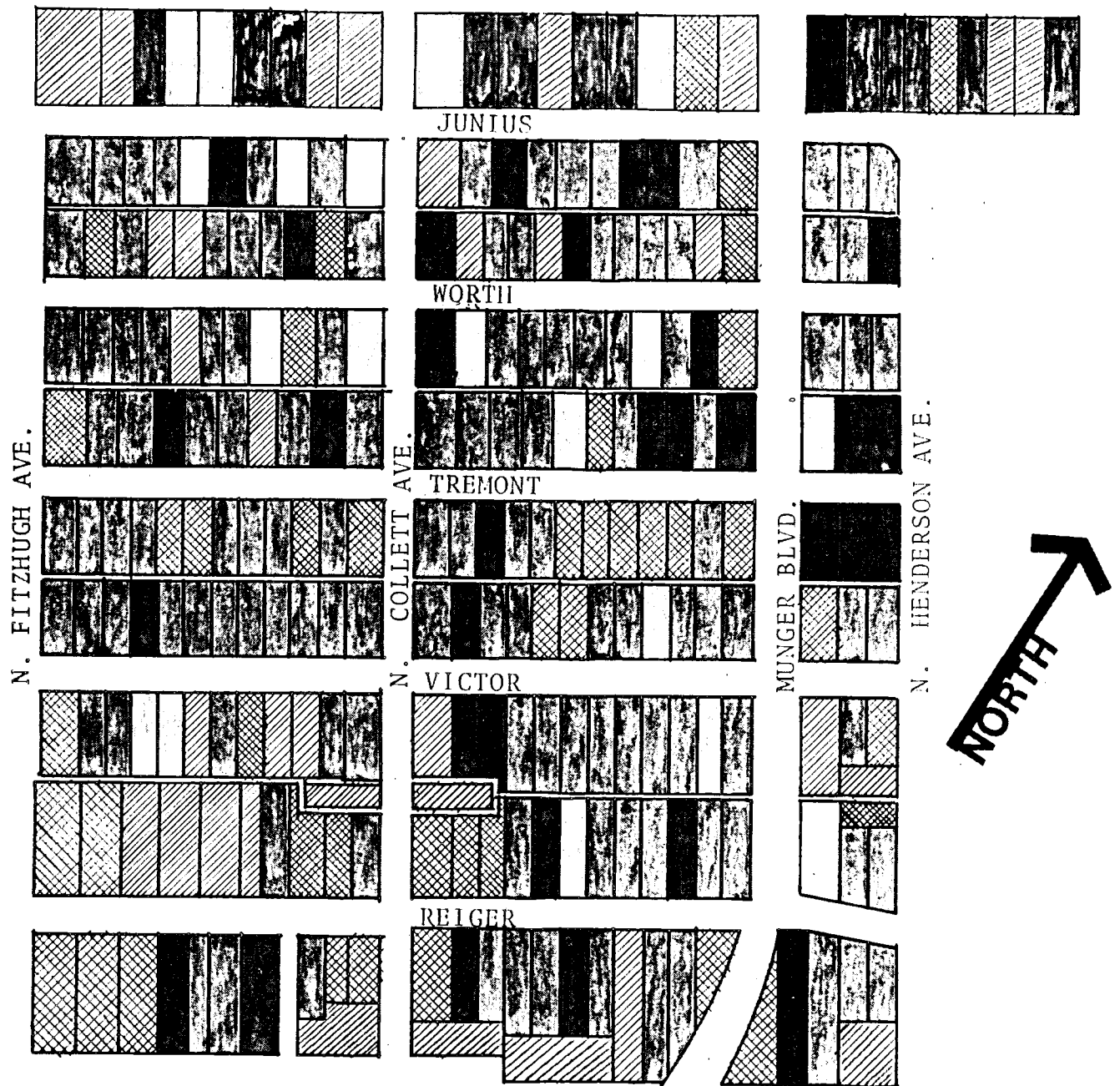





- 1 ARCHITECTURAL STYLE QUALITIES
- 2 STRUCTURAL QUALITIES
- 3 LAND USE QUALITIES
- 4 NATURAL FABRIC

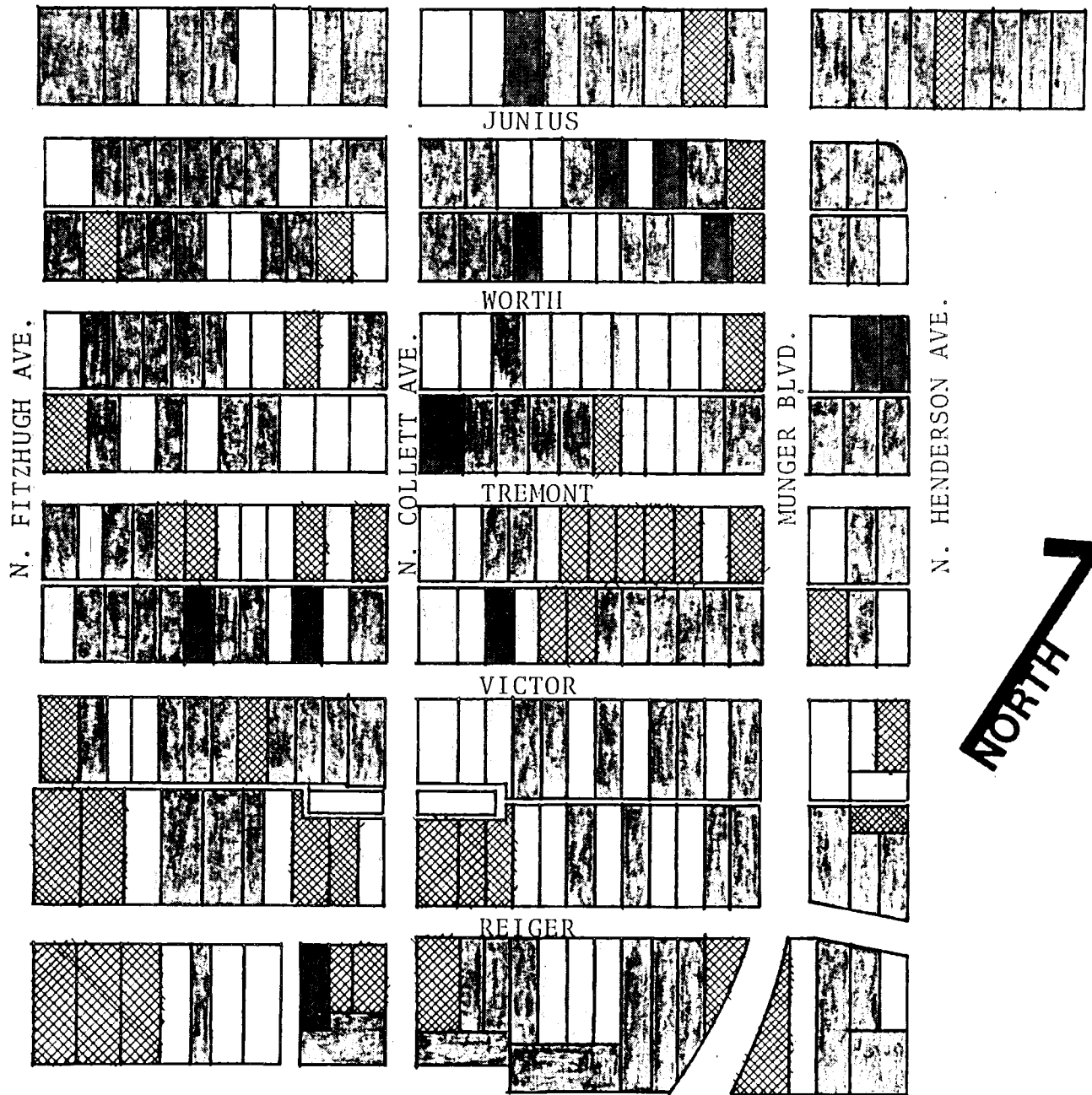

-  DISTRICT LANDMARK
-  SIGNIFICANT BUILDING-LITTLE OR NO FACADE ALTERATION
-  SIGNIFICANT BUILDING-CONSIDERABLE FACADE ALTERATION
-  MODERN APARTMENTS OR NON-RATED BUILDINGS
-  VACANT LOTS

FEBRUARY 1976



-  LITTLE OR NO DETERIORATION--WELL MAINTAINED
-  SOME DETERIORATION--NEED FOR REPAIRS EVIDENT
-  BADLY DETERIORATED--EXTENSIVE REPAIRS NECESSARY
-  VACANT LOTS

MARCH 1976

STRUCTURAL QUALITIES

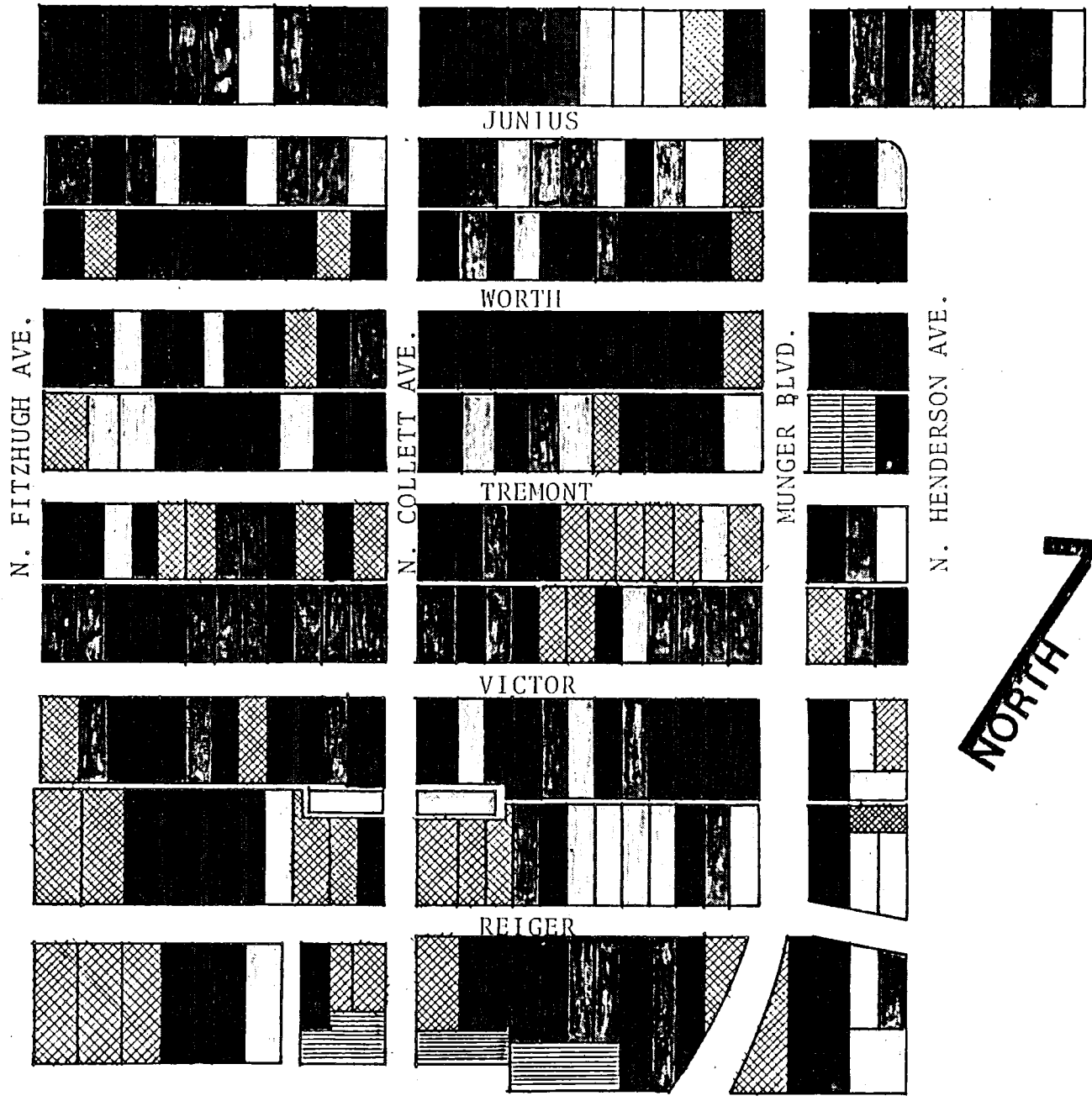

N. FITZHUGH AVE.

N. COLLETT AVE.

MUNGER BLVD.

N. HENDERSON AVE.

JUNIUS







WORTH

TREMONT

VICTOR

REIGER

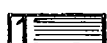

-  SINGLE FAMILY
-  DUPLEX
-  MULTI-FAMILY
-  APARTMENTS
-  COMMERCIAL
-  VACANT

MARCH 1976

NATURAL FABRIC

While investigating the natural fabric-trees and terrain-of Munger Place several patterns became evident.

1. Trees are systematically planted between curb and sidewalk to form a semicovered alleyway for the street. There are exceptions to this but they are minor. Most of these trees would seem to have been planted rather than have occurred naturally due to their regular placement. With the exception of the hackberry, elm, and pecan I feel the trees at curbside are not native to the area. There is some question if the hackberry would be as dominant as it is in this curbside area if it had been planted in a ratio to the hackberry occurring naturally behind the houses.
2. The next pattern to evolve is the area behind the houses which have trees that are native to the area, mainly the pecan and elm. There are two reasons for feeling these are native to the area.
 - A. They do not seem to be systematically placed.
 - B. They are usually much taller than those at curbside suggesting greater age and the possibility they existed before housing development was initiated.

Apparently, the hackberry existed naturally in this backyard area as well but not in the numbers now existing at curbside. Hackberries are usually considered a "weed" by botanists as it grows rapidly where nothing else will. Thus it is used generously by the untrained home owner to produce quick shade. Usually the hackberry is replaced with pecan or elm as it naturally dies out. In the backyard area there does not seem to be a definite pattern or grouping for the elm or pecan. They seem to have a random scattering with no large concentration of any one species.

3. A third characteristic of the natural fabric of Munger Place is the streets system. Those streets running north and south seem to make up the neighborhood while the ones running east and west, mainly Munger and Collett, seem to interrupt the neighborhood and the pattern of tree-lined curbs. These

streets obviously later became arteries to deliver people through the neighborhood on their way to another part of the city. Possibly this is made more apparent by their having been widened. The planting of trees at curbside could alleviate some of this problem. The medians being planted certainly are a step in the right direction, as they help to incorporate these major thoroughfares into the neighborhood.

4. Specimen plantings occur and they are regarded as exceptions to the natural fabric of the neighborhood. They do provide interest and relief to the overall natural fabric.
5. The terrain of the area is flat. It is reminiscent of a river bottom with the tall elms and pecans.

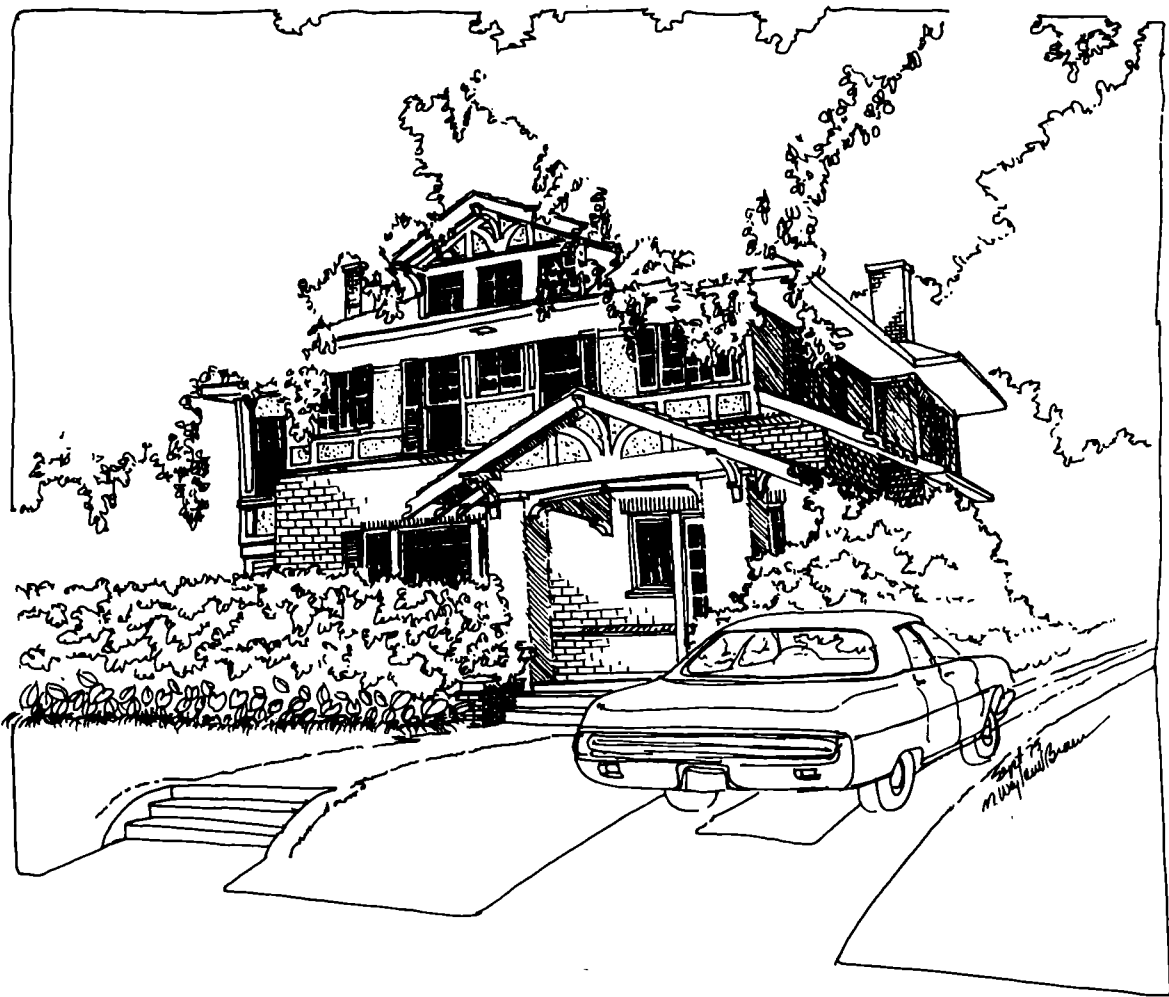

- 1 ARCHITECTURAL CHARACTER SKETCHES
- 2 ARCHITECTURAL DETAIL SKETCHES

4

APPENDIX B

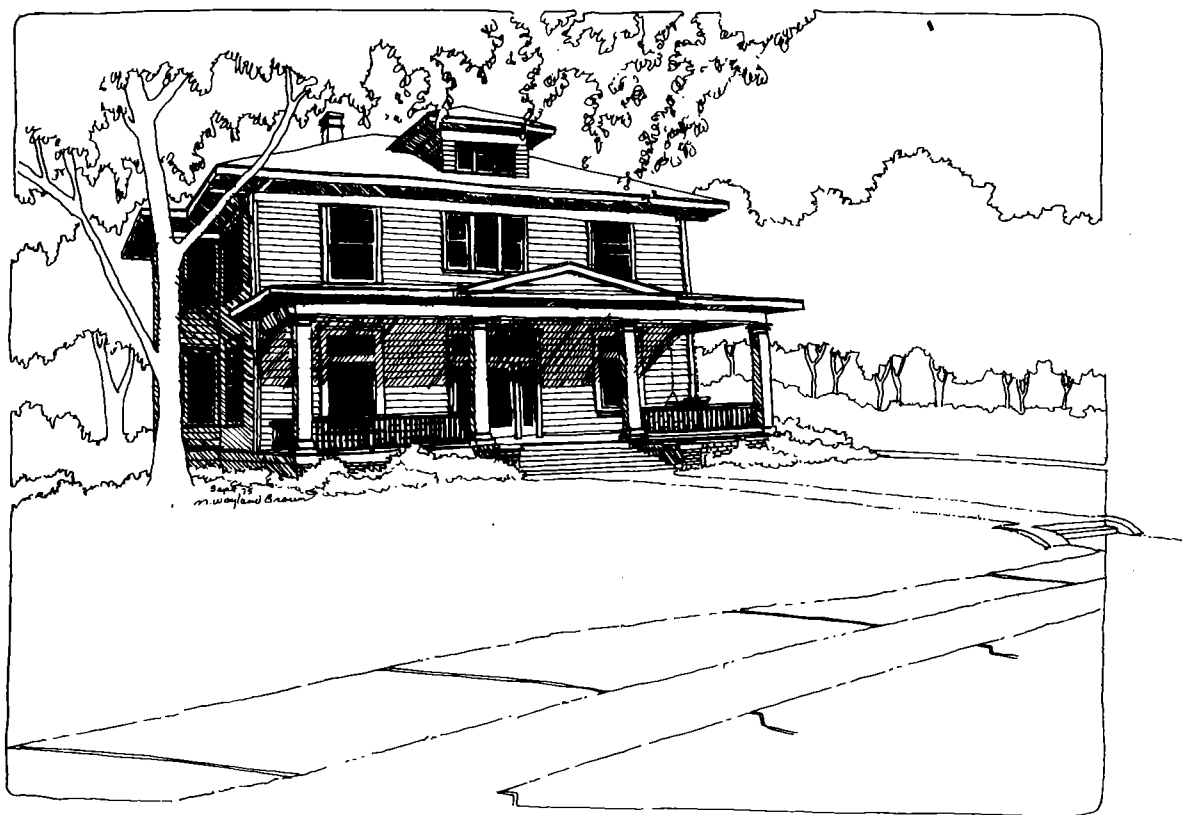

- 1 MAP OF RESEARCH AREA
- 2 SURVEY OUTLINE
- 3 ARCHITECTURAL STYLE INVENTORY
- 4 STRUCTURAL SURVEY
- 5 LAND USE SURVEY

5

APPENDIX C

- VI. Architectural Qualities
 - A. Style Qualities
 - B. Dimensional Qualities
 - 1. Side Yards
 - 2. Set Back
 - 3. Building Heights
 - C. Facade
 - 1. Colour
 - 2. Materials
 - 3. Landscaping
 - D. Rhythm Qualities
 - 1. Doors & Windows
 - 2. Porches
 - 3. Roofs & Dormers
 - 4. Chimneys
 - E. Photographs

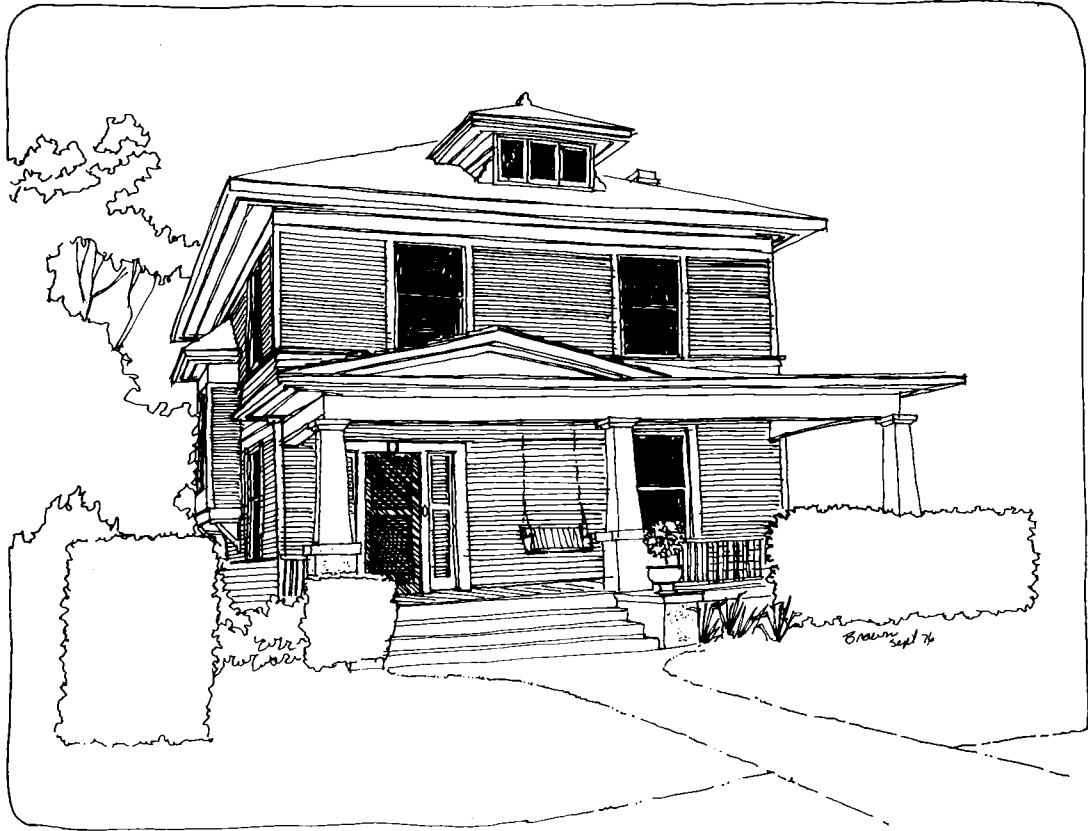

6

CREDITS

CREDITS

This survey could not have been completed without the help of the many people who gave up their Saturdays, weekday evenings, burned untold gallons of gasoline, wore out their shoe leather, dodged abusive language and dogs with big teeth and answered inquiries from interested (and sometimes irate) neighbors, braved freezing winter weather and sweltered in summer heat to gather their tidbits of information. To all of those die-hards go our sincere thanks and appreciation.

TASK FORCE CHAIR PERSONS

| | |
|--------------------------------|--------------------------------------|
| Historic Research | <i>R. Hal Williams</i> |
| Land Use | Richard Trimble |
| Natural Fabric | Gary Johnson |
| Structural Qualities | Tom Dance Lee McAlester |
| Renovation Qualities | Doug Newby |
| Architectural Qualities | Lee McAlester Robert Butler |
| Dimensional Qualities | Mike Longcrier |
| Photograph Identification | Jim and Beth Richards |
| Special Secretarial Assistance | Susan Evans |
| Special Background Assistance | Virginia Talkington Lyn Dunsavage |
| Sketches | M. Wayland Brown |

And to all others, too numerous a list, who assisted in some aspect of the survey, our appreciation is expressed.

Special Appreciation Is Given To
The Dallas City Plan Department,
Weiming Lu, And Alan Mason.

All Rights Reserved
An Historic Preservation League, Inc. Publication
P. O. Box 140460
Dallas, Texas 75214

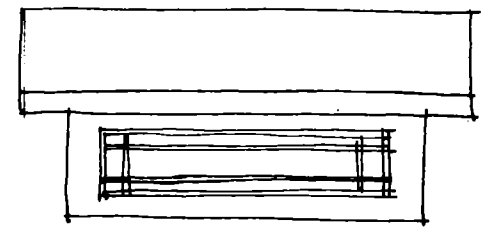
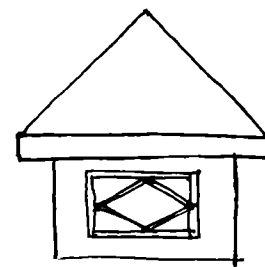
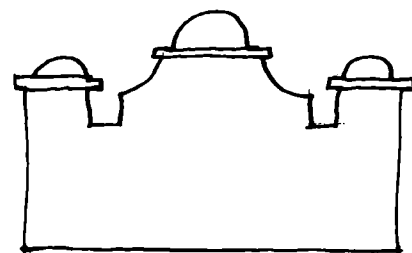
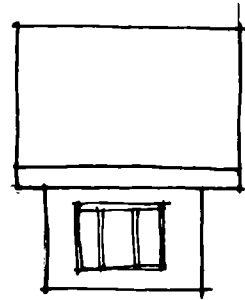

DORMERS

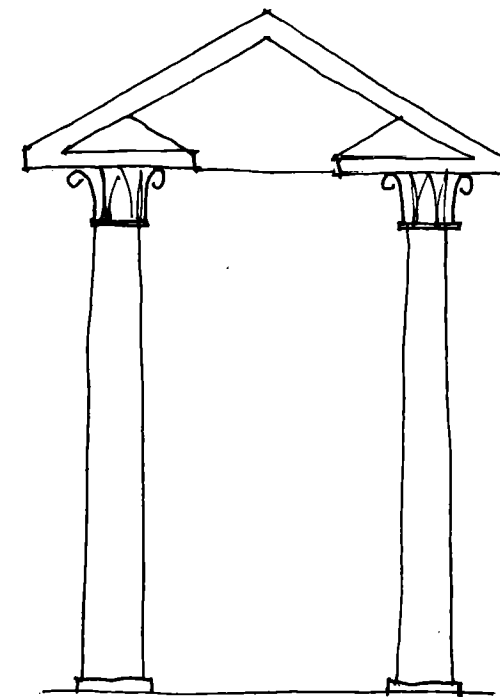
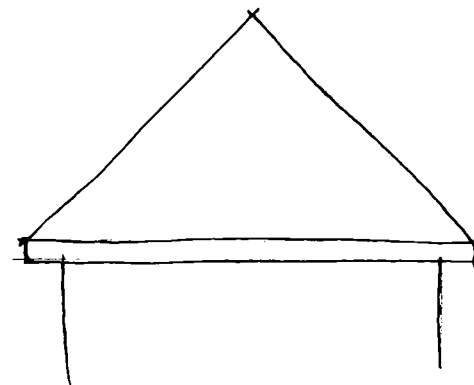
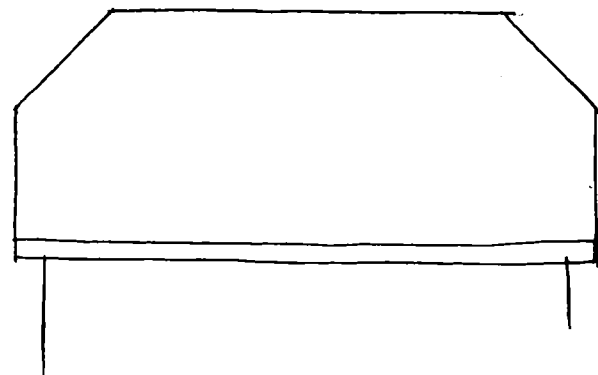
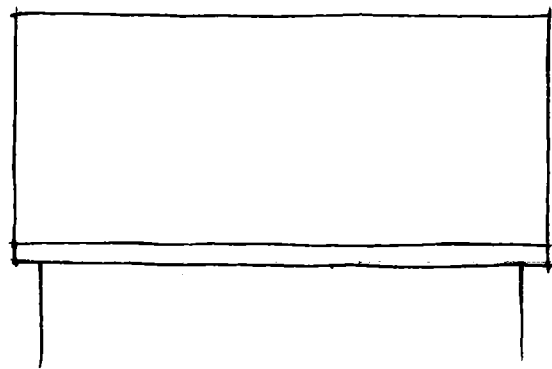

ROOFS

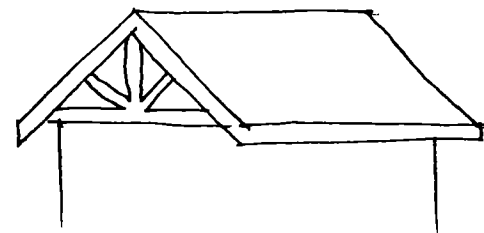
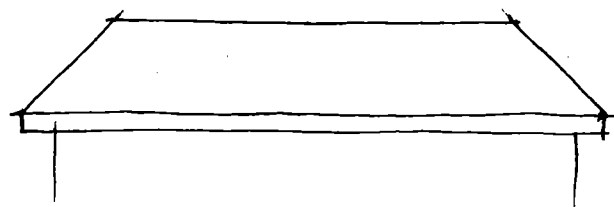
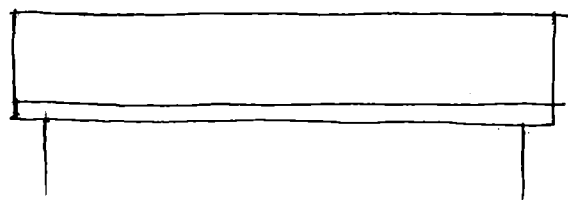

PORCHES

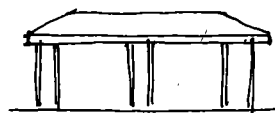
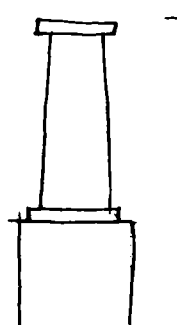
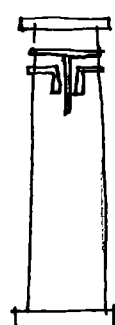
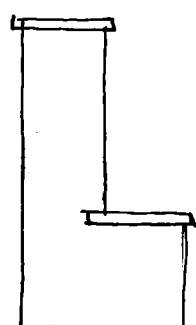
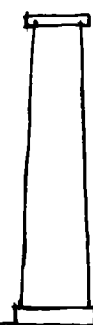

TYPICAL COLUMN PATTERNS

COLUMNS

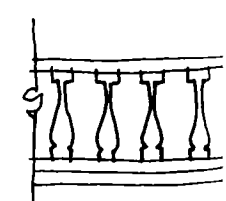
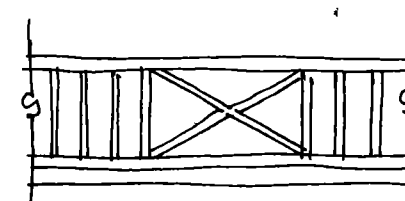
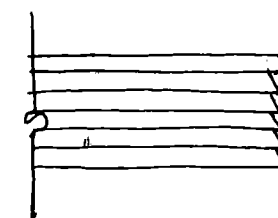
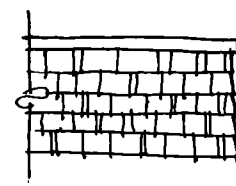
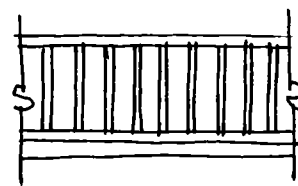

PORCH RAILS

TYPICAL MOTIFS

BOXE
RAF

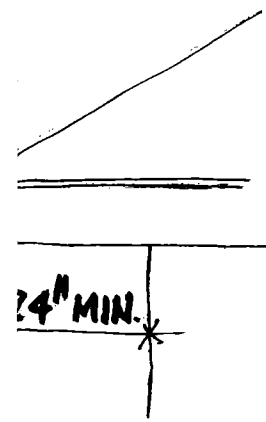

ED IN
TER

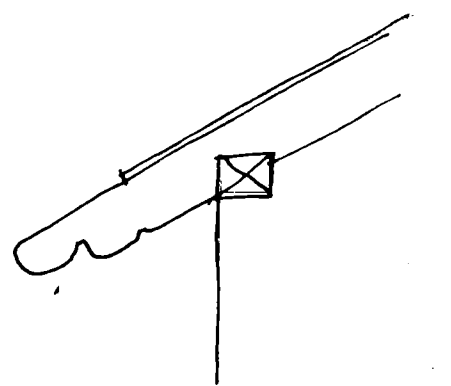

DECORATIVE
OPEN END RAFTERS

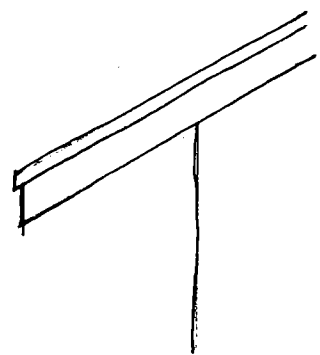

PLAIN OPEN
END RAFTERS

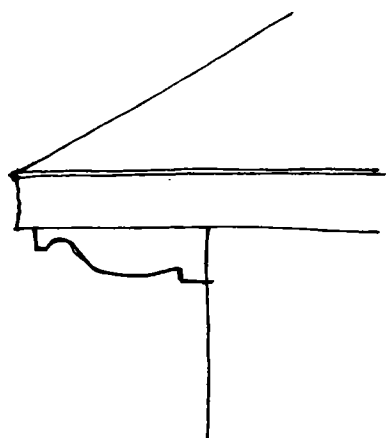

BRACKET

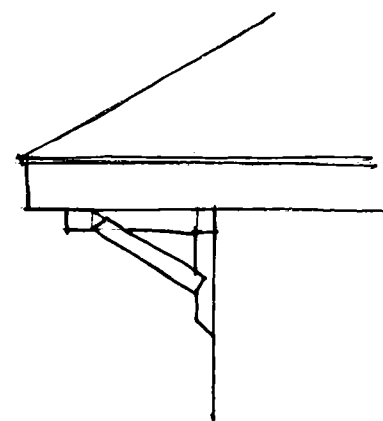

BRACKET

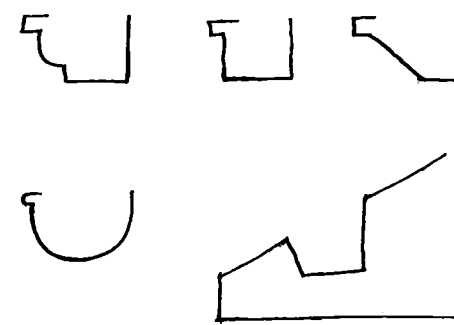

TYPICAL GUTTER
SHAPES

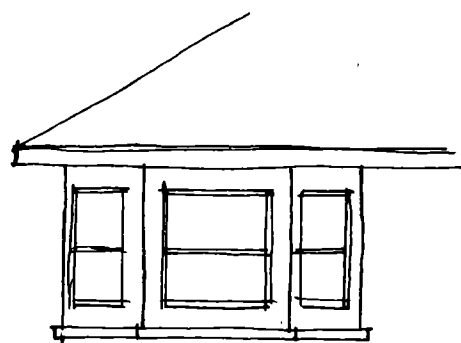
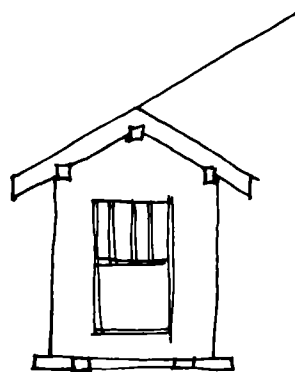
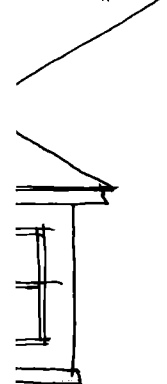

BAY WINDOWS

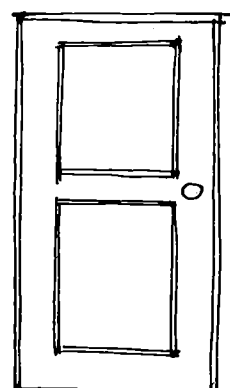
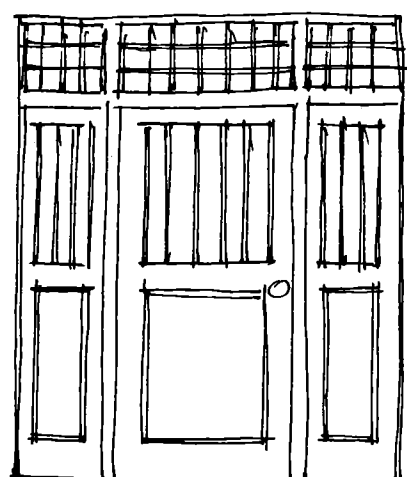
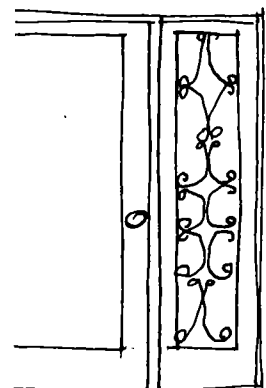
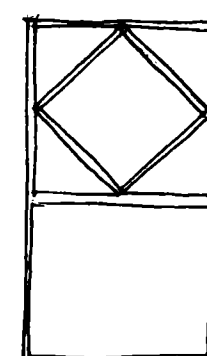
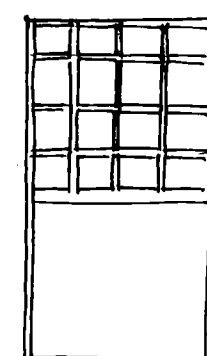
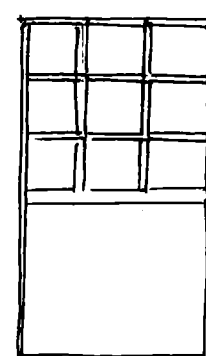
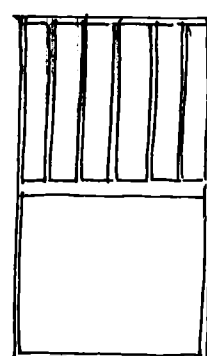
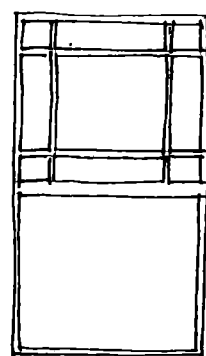

FRONT DOORS

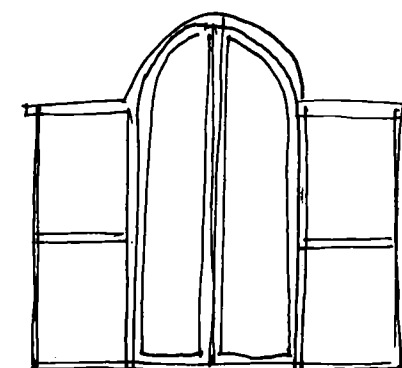

TYPICAL WINDOWS

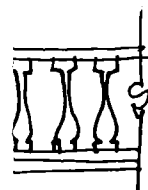

- A - BUILDING HEIGHT 26' MIN - 32' MAX
- B - ROOFS NO FLAT OR MANSARD - USUALLY HIPPED - GABLED OR BROKEN HIP
- C - LARGE EAVE OVERHANGS - 24" MIN.
- D - ENTRANCES - STRONG VISUAL DEFINITION
- E - PORCHES - FULL FRONT WIDTH - SOMETIMES "L" SHAPED - RARELY "U" SHAPED

- F - FOUNDATION UNDERPINNING - BRICK - PRESSED METAL SHINGLES - CLAPBOARD OR SHAPED SIDING
- G - FRONT STEPS - WOOD OR CONCRETE WITH HEAVY WOOD OR BRICK END CLOSURES
- H - SIDING - USUALLY WOOD - OCCASSIONALLY BRICK

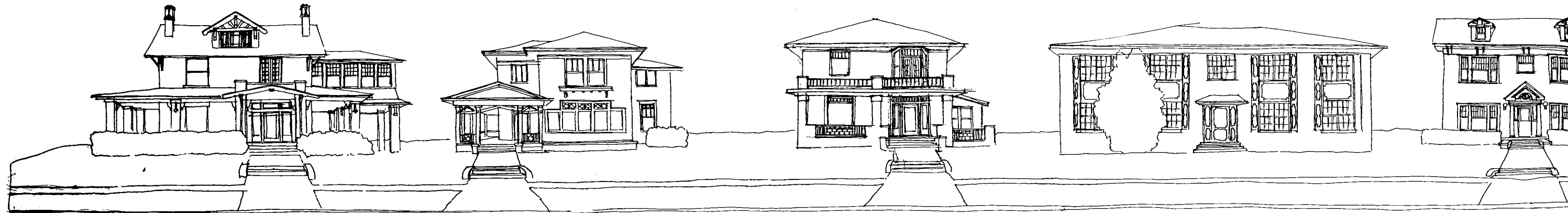

5001

5007

5011

5015

5025

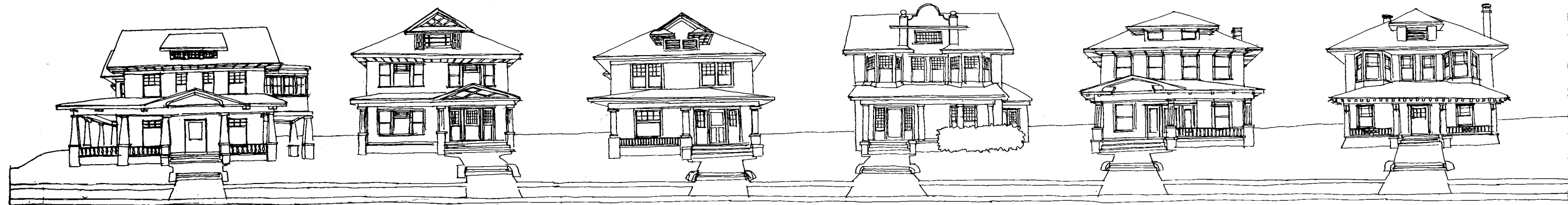

4901

4905

4909

4915

4921-4923

4929

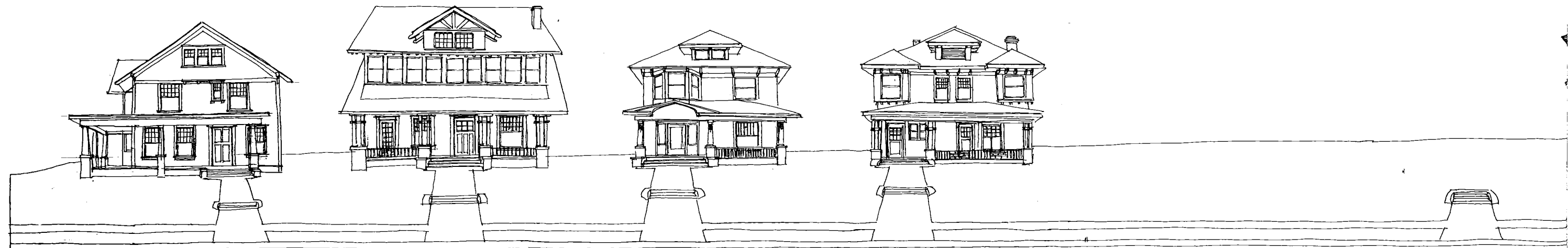

5003

5007

5011

5015

5017

5019

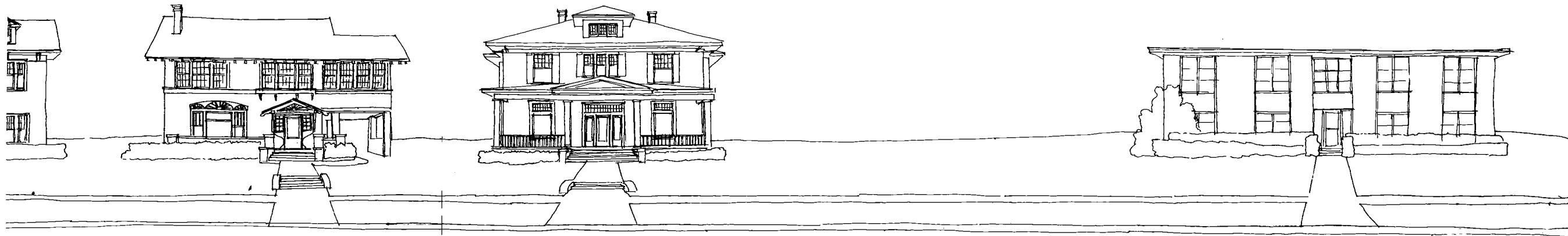

5105

5107

5111

5115

JUNIUS STREET



4933

4935

4937

4943

4947

4940

VICTOR STREET



5101

5107

5111

5115

5119

5123

VICTOR STREET

TYPICAL STREETScape