

OFF-STREET PARKING AND DRIVEWAYS HANDBOOK

June 2004

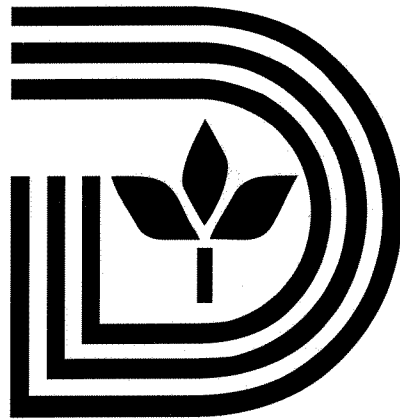

**CITY OF DALLAS
DEPARTMENT OF
DEVELOPMENT SERVICES**

ACKNOWLEDGMENTS

The City of Dallas wishes to acknowledge the assistance of many individuals who contributed in the preparation of this document.

Primary responsibility for the compilation, review coordination, authorship of much of the manual revisions was from Elias Sassoon, P.E. of the Development Services Department. Others providing review and additional assistance were David Dybala, P.E., Liz Fernandez, P.E., Jack Antebi, P.E., John Brunk, P.E., Ben Cernosek, P.E., Ken Melston, P.E. of the Public Works and Transportation Department, Hamid Darbandi-Fard, P.E., Chau Q. Nguyen, P.E., Carol Buckingham, Francena Holloway of the Development Services Department and Kathy Glegg of the City Attorney Office.

It must be mentioned that without the overall support and encouragement of Theresa O'Donnell, the Director of the Development Services and David Dybala, P.E., the Director of Public Works and Transportation, this document would not have materialized. Furthermore, all the hard work of Hamid Darbandi-Fard, P.E. and Chau Q. Nguyen, P.E. is hereby acknowledged and appreciated.

Many other City staff not mentioned also contributed to this Off-Street Parking and Driveways Handbook. The City is very appreciative of the dedicated efforts of all the groups and individuals who have made this possible.

NOTE

This **OFF-STREET PARKING AND DRIVEWAYS HANDBOOK** is a guideline, and is not intended to replace the city code, or state or federal law. Always check the city code, state and federal law for details, exceptions, and amendments.

In the event of a conflict between this document and the city code or other legal authority, the city code or other legal authority supersedes.

TABLE OF CONTENTS

PART ONE DRIVEWAYS

I.	INTRODUCTION	page 6
II.	CHOOSING LOCATION FOR A DRIVEWAY	page 6
	A. COORDINATING DRIVEWAY ACCESS WITH STREET FUNCTION	page 6
	1. Determining Street Functional Classification	page 6
	2. Choosing the Street for Access	page 7
	3. Spacing Between Driveways	page 7
	4. Property Clearance for Driveway	page 8
	5. Intersection Clearance for Driveway	page 8
	6. Joint Driveway Access	page 8
	7. Driveways on Service Roads, or near Railroad	page 8
	B. ENVIRONMENTAL CONSTRAINTS FOR DRIVEWAYS	page 8
	1. Proximity to Utilities and Drainage Devices	page 9
	2. Adjacency to Free Right-Turn Lanes	page 9
	3. Coordinating with Existing Roadway Features	page 9
	4. Providing Adequate Visibility for a Driveway Approach	page 9
	a. Visibility Triangles at a Driveway Approach	page 9
	b. Stopping and Intersection Sight Distances at a Drive Approach	pg 10
III.	DESIGN GUIDELINES FOR DRIVEWAYS	page 11
	A. PLAN GEOMETRICS OF DRIVEWAYS	page 11
	1. Number of Driveway Approaches	page 11
	2. One-way Driveways	page 11
	3. Driveway Angle of Approach	page 11
	4. Driveway Entry Width and Curb Return Radii	page 12
	a. The Design Vehicle	page 12
	b. Curb Return Radius	page 12
	c. Entry Width vs. Overall Width	page 12
	d. Practical Design	page 13
	e. Accommodating Large Trucks	page 13
	5. Deceleration Lanes for Driveways	page 14
	6. Channelization of Driveways	page 14
	a. Island Size	page 14
	b. Turning Roadway Width and Radii	page 14
	7. Storage Considerations for Driveways	page 15
	a. Storage Length	page 15
	b. Drive-through Design	page 15
	8. Control Gate Setback for Private Streets/Driveways	page 15

	B. DRIVEWAY GRADES AND DRAINAGE CONTROL	page 16
	1. Driveway Grades	page 16
	a. Minimum and Maximum Grades, G1	page 16
	b. Grade Beyond the Property Line, G2	page 16
	2. Accommodating Drainage Facilities	page 16
IV.	MEDIAN OPENINGS	page 17
	A. GENERAL	page 17
	B. DESIGN CRITERIA	page 17
	1. Arterials and Collector Thoroughfares	page 17
	2. Freeways and Expressways	page 18
V.	PERMITS FOR AND CONSTRUCTION OF DRIVEWAYS	page 18
	A. APPLYING FOR PERMITS	page 18
	B. REQUIREMENTS FOR PERMIT APPLICATION	page 18
	C. CONSTRUCTION OF DRIVEWAYS	page 19
	1. Removal of Curb and Gutter Where Required	page 19
	2. Concrete	page 19
	3. Reinforcing Steel	page 19
	4. Placement and Compaction of Concrete	page 19
	5. Finishing	page 20
	6. Protection from Vehicular Traffic	page 20
	D. FINAL ACCEPTANCE OF DRIVEWAYS	page 20
	E. ABANDONMENT OF DRIVEWAY APPROACHES	page 20

* * *

PART TWO

OFF-STREET PARKING

I.	INTRODUCTION	page 21
II.	OFF-STREET PARKING SPACES	page 21
	A. COMPUTING NUMBER OF REQUIRED PARKING SPACES	page 21
	1. Special Parking Regulations	page 21
	a. Shared Parking	page 21
	b. Remote Parking	page 22
	c. Packed Parking	page 22
	2. Procedures for Special Parking Approval	page 22
	B. HANDICAPPED PARKING SPACES	page 22
	1. General	page 22
	2. Number of Required Handicapped Parking Spaces	page 22
	3. Location of Handicapped Parking Space	page 23
	4. Specifications of Handicapped Parking Space	page 23
	5. Parking Structures and Remote Lots for the Handicapped	page 23
	6. Passenger Loading Zone for the Handicapped	page 23
	C. SMALL OR COMPACT CAR ALLOWANCE	page 24
III.	TYPES OF PARKING LAYOUTS	page 24
	A. RIGHT ANGLE PARKING (90°)	page 24
	B. OTHER ANGLES PARKING (30° TO 80°)	page 24
	C. PARALLEL PARKING SPACES	page 25
IV.	PROVIDING ADEQUATE CIRCULATION FOR PARKING SPACES	page 25
V.	DESIGN CONSIDERATIONS FOR PARKING SPACES	page 25
	A. GEOMETRICS: TURNING RADIUS OF DESIGN VEHICLES	page 25
	B. VISIBILITY TRIANGLES AT DRIVEWAYS, ALLEYS, AND STREET INTERSECTIONS	page 25
	C. MATERIALS FOR PARKING SPACES	page 26
	1. Pavement Standards	page 26
	2. Wheel Guards	page 26
	3. Pavement Markings	page 27
	D. DRAINAGE FOR PARKING SPACES	page 27
	E. LIGHTING AND SCREENING FOR OFF-STREET PARKING	page 27
	1. Lighting Provisions for Off-Street Parking	page 27
	a. Lighting Provisions for Commercial Parking Lots	page 27
	b. Lighting Provisions for Other Off-Street Parking	page 28
	2. Screening Provisions for Off-Street Parking	page 28
VI.	CONSTRUCTION AND MAINTENANCE OF PARKING SPACES	page 28
	A. CONSTRUCTION OF PARKING SPACES	page 28
	1. Single Family or Duplex Use	page 28
	2. Other Uses	page 28
	B. MAINTENANCE OF PARKING SPACES	page 29
	* * *	
	REFERENCE LIST	page 5
	LIST OF TABLES/ FORMS/ FIGURES	page 5

REFERENCE LIST :

- A POLICY ON GEOMETRIC DESIGN OF HIGHWAYS AND STREETS, AASHTO, 1994
- DALLAS CITY CODE
- DEPARTMENT OF PW&T, PAVING DESIGN MANUAL, JUNE 1998
- DEPARTMENT OF PW&T, STANDARD CONSTRUCTION DETAILS, UPDATED SEPT 2002.

LIST OF TABLES/ FORMS/ FIGURES :

TABLES :

TABLE 1:	SPACING BETWEEN DRIVEWAYS, MIN. PROPERTY CLEARANCE	page 30
TABLE 2:	CLEARANCE DISTANCE TO INTERSECTION FOR DRIVEWAYS	page 30
TABLE 3:	D-VALUE FOR USE WITH FIGURE 2	page 30
TABLE 4:	STOPPING AND INTERSECTION SIGHT DISTANCES	page 31
TABLE 5:	SIGHT DISTANCE ADJUSTMENTS DUE TO GRADE	page 32
TABLE 6:	ENTRY WIDTHS OF DRIVEWAYS	page 32
TABLE 7:	DECELERATION LANE LENGTH INCLUDING TAPER	page 32
TABLE 8:	PAVEMENT WIDTHS FOR TURNING ROADWAYS	page 33
TABLE 9:	VEHICLE STORAGE LENGTHS FOR DRIVEWAY EGRESS	page 33
TABLE 10:	DRIVEWAY PROFILE, STANDARDS FOR GRADES	page 33
TABLE 11:	PARKING BAY WIDTH	page 34.

FORMS :

FORM 1:	BUILDING INSPECTION APPLICATION
FORM 2:	CITY OF DALLAS PAVING BOND FORM
FORM 3:	PERMIT APPLICATION (FOR CONSTR. ACTIVITY WITHIN THE R-O-W)
FORM 4:	PERMIT APPLICATION (SHORT FORM)
FORM 5:	STREET EXCAVATION DATA FORM
FORM 6:	STREET EXCAVATION PERMIT (SAMPLE).

FIGURES :

FIGURE 1:	DRIVEWAY STANDARDS
FIGURE 2:	MINIMUM DISTANCES FROM INTERSECTION FOR DRIVES
FIGURE 3:	PREFERRED ACCESS CONTROL – ENTRANCE AND EXIT RAMP
FIGURE 4:	VISIBILITY TRIANGLE GUIDELINES
FIGURE 5:	SIGHT DISTANCE AT INTERSECTIONS
FIGURE 6:	DETAIL FOR GATED ENTRY
FIGURE 7:	DRIVEWAY PROFILE
FIGURE 8:	DRIVES WITHOUT CULVERTS
FIGURE 9:	DRIVES WITH CULVERTS
FIGURE 10:	HANDICAPPED PASSENGER LOADING ZONE AND SIGNAGE
FIGURE 11:	HANDICAPPED PARKING
FIGURE 12:	DESIGN VEHICLE FOR PARKING STALL DESIGN
FIGURE 13:	RIGHT ANGLE PARKING (90°)
FIGURE 14:	30° ANGLE PARKING
FIGURE 15:	40° ANGLE PARKING
FIGURE 16:	50° ANGLE PARKING
FIGURE 17:	60° ANGLE PARKING
FIGURE 18:	70° ANGLE PARKING
FIGURE 19:	80° ANGLE PARKING
FIGURE 20:	STRUCTURED PARKING GARAGE
FIGURE 21:	P DESIGN VEHICLE TURNING RADIUS
FIGURE 22:	SU DESIGN VEHICLE
FIGURE 23:	BUS DESIGN VEHICLE
FIGURE 24:	WB-50 SEMI-TRAILER COMBINATION VEHICLE
FIGURE 25:	FIRE TRUCK TURNING TEMPLATE
FIGURE 26:	AUTOMOBILE OVERHANG DIMENSIONS
FIGURE 27:	METHODS FOR MARKING PARKING STALLS
FIGURE 28:	STRIPING DETAILS FOR COMPACT CAR SPACES
FIGURE 29:	SAMPLE LAYOUT FOR PARKING ON 50' AND 60' LOTS.

PART ONE

DRIVEWAYS

I. INTRODUCTION

Any owner, authorized agent, lessee, or contractor who intends to construct, enlarge, or alter any driveway approach within the City of Dallas right-of-way must first apply to the Building Official to obtain a permit.

The issuance of driveway permit is based on compliance with several ordinances and policies governing the location and design of driveways.

This document is intended to guide interested parties through these policies by providing information necessary in planning a safe and efficient access point for their property.

Reference:

Dallas City Code, Sec. 43-78 thru 43-95, and Sec. 43-140 thru 43-146,
Public Works and Transportation, Standard Construction Details, File 251D-1, Sept 2002,
Public Works and Transportation, Paving Design Manual, June 1998.

II. CHOOSING LOCATION FOR A DRIVEWAY

The location and layout of a driveway can have considerable impact on the effective operation of adjoining streets and of the property itself. It is for this reason that the City of Dallas has adopted several policies regulating the location of driveways.

Applicable policies and statutes include those governing the coordination of driveway access with street function, and those outlining limitations regarding potentially hazardous environmental conflicts.

A. COORDINATING DRIVEWAY ACCESS WITH STREET FUNCTION

Several of the policies that the City has adopted with regards to driveway location involve an appraisal of the driveway's impact on the adjoining street's operation. This evaluation is often dependent on what is called the functional classification of the street.

1. Determining Street Functional Classification

Streets are classified into three functional classes: local streets, collectors, and arterials.

Local Streets provide access to adjacent property, and generally link properties to the formal roadway network.

Collectors provide the link between the local streets and the arterials. They serve the function of collecting or distributing traffic between the arterials and local streets.

Arterials provide the link between areas of the city by moving traffic within the city and between cities. Arterials provide a minimal role in providing property access, and their use as such should be limited to major traffic generators only.

To determine the official classification of a given street, refer to the City of Dallas Thoroughfare Plan or consult with an appropriate city official.

2. **Choosing the Street for Access**

In situations where a property has access to two (2) or more streets, City of Dallas policy prescribes locating driveways on those streets whose function is most consistent with providing appropriate access.

In new development, for residential property abutting a divided thoroughfare, driveway access to the thoroughfare is not allowed. Refer to Dallas City Code 51A-8.503(c).

3. **Spacing Between Driveways**

When driveways are located too close together, areas of conflict with the main flow of traffic overlap causing an increase in the accident potential for the area and a reduction in the operating efficiency of the street.

This effect is much more exaggerated on higher-speed facilities such as arterials whose designs are intended to promote efficiency through movement.

For this reason, the City of Dallas recommends desirable spacing between driveways for a given street functional classification (see Table 1).

Should a property not be of sufficient frontage to provide this spacing, joint driveway access with an adjacent property may be pursued as a desirable solution.

The following are additional points to consider:

- * The minimum distance between driveways, measured from the edges of driveway throats, is normally 20 feet except for local streets.
- * The island separating a pair of one-way, 90-degree driveways should have a minimum width of 20 feet (Dallas City Code, Sec. 43-85). The island between a pair of angle-driveway approaches should equal or exceed 75 square feet in area.
- * The number of driveway approaches serving a property abutting arterials should be minimized. No more than two driveway approaches should be designed on any parcel of property with a frontage of 150 feet or less (Dallas City Code, Sec. 43-84).
- * Driveways generating at least 250 vehicles in a 12-hour period should be located and designed to align with existing or proposed median opening to facilitate efficient and safe traffic access.
- * Driveways should be designed to line up with the centerline of existing driveways on the other side of street.

4. **Property Clearance for Driveway**

Property Clearance is the distance between the side property line (perpendicular and intersecting with the roadway) and the nearest edge of the driveway.

The minimum property clearance distance is shown in Table 1 and Figure 1.

Dallas City Code also requires that the driveway's curb radius not encroaching upon the property line of adjacent properties.

See City of Dallas, Standard Construction Details, File 251D-1 for more details.

5. **Intersection Clearance for Driveway**

Spacing between the adjacent cross-street and a driveway should be adequate to avoid having driveway-conflict-areas which would interfere with the safe and efficient operation of the intersection.

In addition, queuing, which occurs at signalized intersections, can interfere with the movement of vehicles into and out of the property. Tables 2 and 3, and Figure 2 specify City of Dallas requirements for minimum clearances to intersection for driveways.

6. **Joint Driveway Access**

Sharing driveway access with adjoining property owners is an option that is encouraged by the City, and is in most cases permitted providing that joint application is made by all affected parties.

The utilization of joint driveways can be beneficial to those properties that abut arterials with relatively restricted access points.

7. **Driveways on Service Roads, or near Railroad**

Driveway cuts on service roads not operated by the City of Dallas, such as State Highways and Tollway facilities, are regulated by the appropriate governmental agency. Therefore, plans for any access abutting such facilities must be approved by the appropriate party as well as by the City of Dallas (See Figure 3).

A driveway approach must not be located within 50 feet of a railroad right-of-way.

B. ENVIRONMENTAL CONSTRAINTS FOR DRIVEWAYS

In planning the location of a driveway, it is important to be aware of several environmental constraints that may influence the placement of the driveway.

1. **Proximity to Utilities and Drainage Devices**

Dallas City Code prohibits the location of driveways within three (3) feet of any utility structures within the public right-of-way. These include fire hydrants, power poles, guy wires, anchors, and mailboxes.

Provisions for the possible relocation of these impeding structures are addressed in the Dallas City Code, Sec. 43-141.

An additional regulation in this respect addresses a driveway's proximity to stormwater drainage curb inlets: the point of tangency between the driveway radius and the street curb shall not be located within ten (10) feet of the edge of a curb inlet.

2. **Adjacency to Free Right-Turn Lanes**

Refer to Figure 2 for driveways located adjacent to free right-turn lanes because of the difficulty for vehicles performing weaving movements necessary to exit the property across the free right-turn lane in order to merge with the through-traffic.

3. **Coordinating with Existing Roadway Features**

When choosing a location for a driveway, the existing roadway features such as median openings, opposing driveways, and cross streets should be examined.

Creating offsets with opposing driveways or streets that might create left-turn conflicts should be avoided. If any median openings exist or are proposed, align the driveway with the median opening or locate the driveway a sufficient distance away from the median opening so that drivers do not attempt to use the median opening illegally (by driving a short distance against the flow of traffic to enter or exit the property).

Also, careful coordination of the driveway's location with the internal circulation patterns of the property is important.

4. **Providing Adequate Visibility for a Driveway Approach**

a. **Visibility Triangles at a Driveway Approach**

It is important that vehicles using the proposed driveway approach be provided sufficient sight distance to allow safe and non-conflicting egress and ingress from the property.

To provide for such visibility, the City of Dallas requires an unobstructed path of sight called "Visibility Triangle" for driveway approaches, as shown in Figure 4.

According to Section 51A-4.602(d)(2)(C) of the Dallas Development Code, the visibility triangle at a driveway approach means the portion

of a lot within a triangular area formed by connecting together the point of intersection of the edge of a driveway or alley and an adjacent street curb line (or, if there is no street curb, what would be the normal street curb line) and points on the driveway or alley edge and the street curb line twenty (20) feet from the intersection, for all zoning districts.

The area bound by the above defined triangle must be free from any visual obstruction between two and one half feet and eight feet in height measured from the top of the adjacent street curb (if there is no adjacent street curb, the measurement is taken from the grade of the portion of the street adjacent to the visibility triangle); this includes parked vehicles, signs, fences, landscaping, berm, or any structure.

b. Stopping and Intersection Sight Distances at a Drive Approach

However, variations in the vertical and horizontal alignment of the intersecting street may create situations where the driver is not given adequate sight distances through the use of the above visibility triangle.

Consequently, the City of Dallas requires that clear sight paths be provided such that vehicles traveling on the through-street can perceive, react, and stop for any potential conflict at the driveway's intersection. This minimum measure is defined as the stopping sight distance.

In addition to stopping sight distance, intersection sight distance should be checked in cases where potential visual obstructions occur in combination with horizontal or vertical curves.

Adequate intersection sight distance means that there should be sufficient sight distance for the driver waiting at the driveway to safely cross the street without requiring the approaching traffic to reduce speed.

Figure 5 shows an example where minimum intersection sight distance is not provided for either direction as a result of poor design and landscaping. It also gives method to check for intersection sight distances.

To prevent hazardous situations such as that shown in Figure 5 from occurring, always check for the provisions of minimum intersection sight distance either by inspecting the location or by examining the site plans.

Table 4 provides standard stopping and intersection sight distances for various speeds. Table 5 is to be used for Sight Distance Adjustment due to grade.

III. DESIGN GUIDELINES FOR DRIVEWAYS

After choosing the appropriate location for the driveway, one should next concentrate on providing the most efficient design possible in accommodating the needs of the property. The guidelines outlined in the subsequent sections are provided to assist users in interpreting current standards and regulations required for efficient driveway design.

A. PLAN GEOMETRICS OF DRIVEWAYS

1. Number of Driveway Approaches

The number of approaches or access points to any property should be limited to the minimum necessary for safe operation on the property.

For most non-service facilities, one driveway usually is sufficient to meet the demands of the property.

However, additional access points may be considered if adequate driveway spacing can be maintained and the following conditions apply:

- The average driveway volume is expected to exceed 5,000 vehicles per day, or
- The expected peak hour volume would exceed the capacity of a stop sign controlled intersection, or
- A competent traffic analysis shows that more than one access point is needed to properly and safely serve the property.

Refer to this handbook Part II.A.3 and Dallas City Code, Section 43-84.

2. One-way Driveways

In some cases, it may be desirable to plan the access point as a pair of one-way driveways. Such arrangement can be used to separate potentially conflicting maneuvers, and the approaches can be angled so that vehicles can enter or exit at higher speeds.

Provided that there is sufficient frontage to accommodate such design, a pair of one-way driveways should be considered when the average daily traffic exceeds 10,000 vehicles per day on the through street, or if the left-turn volume into the driveway is expected to exceed 40 vehicles per hour.

The principal disadvantage to the use of one-way driveways is the problem in enforcing their directional operation. The one-way driveway should be signed and designed so as not to create potential confusion or situations where drivers may attempt to circumvent the intended operation of the driveway.

3. Driveway Angle of Approach

The minimum allowable angle of approach for a one-way driveway is 45 degrees. Two-way driveways should be designed to intersect the roadway at 90 degrees.

4. **Driveway Entry Width and Curb Return Radii**

The operational efficiency of a driveway can be greatly enhanced by coordinating a driveway's geometric layout with the turning limitations of a critical design vehicle. Ideally, a vehicle should be able to turn into or out of a driveway at a reasonable speed without encroaching upon adjacent lanes.

a. **The Design Vehicle**

As a first step in planning the layout of the driveway, one should identify the critical "design vehicle" to be accommodated by the facility. For example, most residential and small commercial driveways need only to accommodate passenger cars; whereas other commercial or industrial developments will require one driveway that can accommodate the efficient entry of larger vehicles such as single-unit trucks, buses, or full-trailer rigs (WB-50).

The American Association of State Highway and Transportation Officials (AASHTO) have compiled critical dimensions for such design vehicles. In addition, AASHTO publishes several templates, which delineate the minimum turning radii, and swept paths for each of the design vehicles. See Figures 21 thru 25.

b. **Curb Return Radius**

After a design vehicle has been identified, a compatible driveway can be designed by selecting a suitable curb return radius and a corresponding driveway entry width.

The driveway entry width dimension is dependent on the adequacy of the curb return radius in transitioning the design vehicle through the turn necessary to exit or enter the driveway. A longer curb return radius provides a better turning transition and will require less entry width than a small radius will.

Table 6 outlines suggested minimum combinations of driveway entry width and curb return radii for three (3) design vehicles.

c. **Entry Width vs. Overall Width**

The entry width is the approximate width needed at the driveway throat to accommodate the swept path of the turning design vehicle.

The entry widths given in Table 6 are minimums developed from design vehicles turning into a driveway from the rightmost lane of an arterial or collector street. The entry width will differ from the designed driveway's overall width depending on how the driveway will be operated.

Residential driveway approaches have a maximum of 30' in width at the property line. For all uses other than residential, the driveway width has a minimum of 12' and maximum of 40' except for motor

vehicle docks where the maximum is 60' for driveway width. Refer to Dallas City Code, Sec. 43-94 and 43-95, and Figure 1 in this handbook.

d. Practical Design

For practical design, one should provide longer curb return radii in situations where vehicles enter or exit at higher speed or when a high volume of driveway traffic is expected. This is often accomplished when designing for the critical vehicle.

For example, the majority of traffic entering a retail facility is often passenger-type vehicles. However, by designing the driveway for the occasional delivery truck, one has accommodated the entry of delivery trucks and allowed for the higher entry speed of passenger vehicles.

To provide for such practical operation, a pair of one-way driveways separated by a median should provide at least the minimum entry width at the throat of each approach. Likewise, overall width for two-way driveways should ideally be twice the specified entry width.

The overall width may be reduced to as low as the minimum entry width if the environment will permit a turning vehicle's occasional encroachment into adjacent driveway lanes. Justification for such a width reduction is sometimes also warranted for driveways abutted local streets or very low volume collector streets, where vehicles can unobstructively encroach into adjacent street lanes to enter or exit a property.

However, when driveways are located on arterial or high volume collector streets, it is not practical to expect large vehicles to encroach upon adjacent lanes to enter a property. Therefore, driveways on such streets should be designed to ideal standards to allow a design vehicle to turn into the property from the right-most lane.

e. Accommodating Large Trucks

For properties expecting moderate volumes of large truck traffic, it is desirable to provide one well-designed "industrial" driveway to accommodate such vehicles, allowing passenger-type vehicles to use other appropriately designed driveways within the development.

At an industrial driveway, the most efficient design for a large vehicle's turning transition can be made by constructing a curb return with a series of compound curves or by using a simple curb radius with transitioning tapers. The AASHTO's "A Policy on Geometric Design of Streets and Highways, 1994" outlines the procedures for such designs.

5. **Deceleration Lanes for Driveways**

Deceleration lanes for right turns may greatly ease the negative impact a driveway will have on the flow of traffic on a through street. Such a provision will enable right-turning vehicles to decelerate away from the through lanes, therefore lessening the risk of rear-end accidents and reducing impedance to the through-traffic movements.

A deceleration lane should be considered on arterials operating at speeds greater than 35 miles per hour or the average inbound right-turn volume into the driveway is expected to exceed 120 vehicles in the peak hour. Table 7 gives practical deceleration lane lengths including taper.

In cases where several successive driveways warrant the use of deceleration lanes and the spacing is not adequate to avoid encroachment of the deceleration lane into another driveway, a continuous right-turn lane should be used. Also, a continuous right-turn lane should be considered in sections of arterials where 20 percent or more of the directional volume on the arterial makes right turns.

6. **Channelization of Driveways**

Channelization of driveways is the separation of conflicting traffic movements by the use of pavement markings or traffic islands.

The safe, efficient operation of a driveway can be significantly enhanced through the appropriate use of an island separating right-turn egress and left-turn ingress movements (sometimes designed in coordination with a deceleration lane).

Such an island adds efficiency by allowing for simultaneous turning movements, and increases safety by separating potentially conflicting movements and providing a refuge for crossing pedestrians.

a. **Island Size**

Raised islands should be constructed so as to be readily visible and to make obvious the directed course of travel. For this reason islands are required to be at least 75 square feet in area, with 100 square feet of area preferred for most designs.

See Figure 1 for minimum and desirable dimensions.

b. **Turning Roadway Width and Radii**

To facilitate the wide swept paths of turning vehicles and to accommodate higher entry speeds, a minimum width of the turning roadway should be provided to permit the outer and inner wheel tracks of a turning design vehicle to clear the pavement gores by about 2 feet on each side.

Table 8 shows recommended pavement widths and inner radii for accommodating design vehicles on such channelized intersections.

7. **Storage Considerations for Driveways**

Proper storage location and length are crucial to the efficient operation of a driveway. The facility should be designed to maximize the on-site storage of vehicles by providing sufficient driveway throat length and by prudently designing any drive-through facilities.

a. **Storage Length**

The length of storage provided by the throat of the driveway should be sufficient so that divergent or conflicting maneuvers may take place at a distance far away from the driveway's intersection with the street so as to not interfere with or block ingress/egress movements.

Table 9 shows required storage lengths for different land uses.

If a driveway meets the requirements for a Traffic Signal, the minimum storage length and geometry will be determined by the Public Works and Transportation Department.

The combination of sub-standard storage length and insufficient outflow metering can result in situations where police control or unwarranted signalization is requested to alleviate congestion from a property; such means of control are considered undesirable and costly.

b. **Drive-through Design**

On-site storage can also be optimized by the resourceful design of drive-through facilities. Storage of vehicle queuing into a drive-through or other services should be placed so that vehicles do not backup onto the street.

A practical design is one that would orient any drive-through queues around the rear of the lot, thereby maximizing on-site storage.

8. **Control Gate Setback for Private Streets/ Driveways**

If a control gate is used within a private street or driveway to restrict the entry of vehicles, a distance of 40 feet of throat length should be provided to accommodate the queuing of vehicles, and an opening provided for the turn-around maneuver of vehicles (see Figure 6). In addition, for locations with high-speed or high-volume of traffic, throat length of more than 40 feet may be required.

For a private drive such as multi-family districts, the gate must be set back a minimum distance of 20 feet from the back of street curb per Dallas City Code, Sec. 51A-4.602 (a) (2) (B).

B. DRIVEWAY GRADES AND DRAINAGE CONTROL

The profile, or grade, of a driveway should be carefully designed to accommodate the storm water drainage system of the roadway, and to provide a comfortable and safe transition for drivers.

1. Driveway Grades

Driveway grades have standards to ensure adequate drainage of the roadway, and to accommodate mobility of pedestrians and vehicles using the driveway. Figure 7 shows a typical driveway profile. Refer to City of Dallas, Standard Construction Details, File 251D-1 for more information.

a. Minimum and Maximum Grades, G1

The minimum grade for this section between the gutter line and the property line (G1) is 2%, it must be sufficient to bring the finished grade elevation of the driveway at the property line to two inches above the elevation of the top of curb. This is to ensure that the roadway will drain properly and the stormwater drainage runoff does not enter the private property.

The maximum grade for G1 is 8% from the gutter to the proposed outside edge of sidewalk. Crossfall across sidewalk should not exceed 2%, and longitudinal grades for sidewalk should not exceed 8%.

A further limitation on this grade specifies that the maximum change in grade without using a vertical curve in any ten (10) feet of distance is 12% in order to avoid car bumper drag.

b. Grade Beyond the Property Line, G2

City of Dallas policy requires that, where applicable, at least 25 feet of consistent grade be profiled beyond the right-of-way line to ensure adequate replacement design. Such a grade is governed by the limitations listed in Table 10.

The maximum allowable grade beyond the property line (G2) is 14%. See City of Dallas, Public Works and Transportation, Paving Design Manual, June 1998, Section 4.03.12 for further details.

2. Accommodating Drainage Facilities

Drainage in roadside ditches shall not be impeded by any driveway or structure. If an open drainage facility exists, it will be necessary to accommodate the existing system with the utilization of a pipe, culvert, or other drainage device.

Such structures must be of a design approved by the Public Works & Transportation Department. If pipes are used for driveway culverts, the minimum required diameter is 15 inches for residential uses and 18 inches for other uses.

In addition, a driveway must be designed such that drainage water is not diverted from the roadway onto the property.

IV. MEDIAN OPENINGS

A. GENERAL

A median opening is defined as any opening in a center divider on a dedicated public street or a private road to allow for left- or U-turns.

The minimum median opening width is 60 feet. For spacing of median openings, refer to Dallas City Code, Section 51A-8.607; and City of Dallas Standard Construction Details, File 251D-1, page 1001; and City of Dallas, Public Works and Transportation, Paving Design Manual, June 1998, Section 3.02.03 and Section 4.03.11 for further details.

Any owner, developer, or authorized agent who desires to construct, alter or close a median opening within the City of Dallas must submit engineering plans to the Department of Development Services for review and approval.

A private development contract must be executed for any work within public right-of-way and/or easement.

B. DESIGN CRITERIA

Wherever possible, median openings should serve both sides of a street. The following standards for median openings are established to facilitate traffic movement and promote traffic safety.

Median openings will normally be permitted at all intersections with public or private streets. Exceptions would be at certain local streets and driveway approaches where, due to unusual conditions, a hazardous situation would result.

1. Arterials and Collector Thoroughfares

Mid-block median openings or other openings with turns permitted into adjacent property shall meet the following criteria:

- a. The property to be served is a significant traffic generator with demonstrated or projected trip generation of not less than two hundred fifty (250) vehicles in a twelve-hour period.
- b. The following spacing requirements are measured from the noses of the medians:
 - no closer than 350 feet from minor arterial intersections.
 - no closer than 425 feet from principal arterial intersections.
 - no closer than 300 feet from any other median opening.
- c. The median width is sufficient to permit the construction of a left turn lane.

2. **Freeways and Expressways**

There shall be no median opening on freeways and expressways unless it is designed by the responsible government agency.

V. **PERMITS FOR AND CONSTRUCTION OF DRIVEWAYS**

A. **APPLYING FOR PERMITS**

Permits must be obtained prior to starting actual construction of driveway approach.

To obtain the permits, first the “Building Inspection Application” (see Form #1) and the “City of Dallas Paving Bond Form” (see Form #2) should be submitted to the Department of Development Services, Building Inspection Division. If the driveway approach is on an Arterial Thoroughfare, the “Barricade” on Form #1 should be marked so that an appropriate “Barricade Permit” can also be issued.

Then the “Permit Application” (see Form #3) or “Permit Application/ Short Form” (see Form #4) and “Street Excavation Data Form” (see Form #5) should be submitted to the Department of Public Works and Transportation, Inspection Services so that a “Street Excavation Permit” (see Form #6) can be issued. These forms are required for any construction activity within the right-of-way.

B. **REQUIREMENTS FOR PERMIT APPLICATION**

A bonded contractor who is registered with the City of Dallas must be shown on the “Building Inspection Application” (see Form #1) and the “City of Dallas Paving Bond Form” (see Form #2).

The completed Building Inspection Application, Form and plans are submitted to:
Building Inspection Division
Department of Development Services
City of Dallas
320 E. Jefferson Blvd, Room 118
Dallas, Texas 75203.

The “Permit Application” (see Form #3) requires three (3) sets of plan drawn to scale, clearly delineating: the property boundaries, roadway pavement, existing and proposed driveway approaches, any natural or artificial features which might affect the drive approaches. Measured dimensions should be shown wherever relevant.

The completed Permit Application, Form and plans are submitted to:
Inspection Services, Cut Control Section
Department of Public Works and Transportation
City of Dallas
320 E. Jefferson Blvd, Room 312
Dallas, Texas 75203.

C. CONSTRUCTION OF DRIVEWAYS

1. Removal of Curb and Gutter where Required

Where a driveway approach is to be constructed at a location where there exists a curb and gutter, such curb and gutter should be removed to the nearest construction joint.

The driveway approach should extend to the property line. On concrete pavement with monolithic curb, the breakout line needs to be eighteen inches from the back of curb line and should be parallel to and form a right angle with the concrete surface.

Pages 1004, 1004A and 1005 of the City of Dallas, Department of Public Works & Transportation, Standard Construction Details, File 251D-1, show the construction details of driveway approaches.

If there is no curb and gutter along the street:

- Figure 8 shows the construction details of the driveway approaches without culverts.
- Figure 9 shows the construction details of driveway approaches with culverts.

2. Concrete

Driveway approaches should be constructed of one-course concrete, reinforced, six inches minimum thickness. The portion of the driveway between the back of the curb and the breakout line needs to be:

- 6 inches minimum thickness for local residential streets.
- 8 inches minimum thickness for any other street, or to match existing pavement thickness.

The concrete should have a minimum compressive strength of 4000 pounds per square inches at 28 days.

The quantity of mixing water should not exceed seven gallons per sack (94 pounds) or Portland cement. The slump of the concrete should not exceed four (4) inches.

3. Reinforcing Steel

Reinforcement steel should consist of No. 3 (three eighths of an inch in diameter) round bars placed not more than 24 inches on centers, both directions. Where steel is lapped, the overlap should not be less than 12 inches or 30 times the bar diameter, whichever is greater.

4. Placement and Compaction of Concrete

Concrete should be compacted with an open face taper and struck off with a straight edge. Concrete should be free from honeycombing, rock pockets and segregation of ingredients.

5. **Finishing**

The surface may have a monolithic finish by floating with a wooden float until a slight excess of sand appears on the surface or may be brushed after troweling in lieu of floating. The surface should not be left slick or with a gloss finish.

Exposed edges of driveway should be rounded with an edger to a radius of one-half inch.

6. **Protection from Vehicular Traffic**

Driveway approaches should be protected from vehicular traffic for a minimum of seven days.

On the seventh day, one set of concrete cylinders should be tested for compressive strength. If the result of this test exceeds 67 percent of design strength, the driveway may be open to traffic.

If this test fails, the other set of concrete cylinders should be tested for compressive strength on the 28th day while the driveway is kept closed to traffic. If the result of this test meets with the design strength, the driveway may be open to traffic. If this test also fails, the standard specification for Public Works Construction, North Central Texas Council of Governments will apply.

D. **FINAL ACCEPTANCE OF DRIVEWAYS**

Upon completion of the field work, the applicant should call for inspection. The assigned inspector will make the necessary field inspection and will review the results of the tests. The inspector will process all the necessary paper work for final acceptance if the work performed meets the minimum standards set by the City of Dallas.

E. **ABANDONMENT OF DRIVEWAY APPROACHES**

Whenever a driveway approach is abandoned and no longer used for vehicular access to the abutting property, it is the responsibility of the abutting property owner to restore the curb and gutter section.

The construction plans must be submitted to and approved by the building official and a "Drive Approach Permit" must be obtained prior to any work to be done.

* * *
*

PART TWO

OFF-STREET PARKING

I. INTRODUCTION

Any owner, authorized agent, lessee, or contractor who intends to construct, enlarge or alter any parking facility within the City of Dallas must first apply to the Building Official to obtain a permit.

The purpose of this document is to guide interested parties for the design and layout of open off-street parking facilities as established by City of Dallas ordinances and policies. Refer to Dallas City Code, Divisions 51A-4.300, 51A-4.310 and 51A-4.320 for more information.

For an enclosed parking space such as garage, the parking space must be at least 20 feet from the property line adjacent to the street or alley if the space faces upon or can be entered directly from the street or alley per Dallas Development Code, Sections 51A-4.301 (a) (9).

II. OFF-STREET PARKING SPACES

A. COMPUTING NUMBER OF REQUIRED PARKING SPACES

The number of required spaces for off-street parking facilities is based upon the type and nature of the land use and the existing and/or proposed development. For example, if an office building is proposed, one (1) parking space is required for every 333 square foot of floor area.

The Dallas Development Code, Sections 51A-4.201 through 51A-4.217 specifies the number of parking spaces required for various developments and uses.

When a lot is used for a combination of uses, the off-street parking requirements are the sum of the requirements for each use, and no off-street parking space for one use is included in the calculation of off-street requirements for any other use, except as otherwise provided in Section 51A-4.301 or Division 51A-4.320 of Dallas Development Code.

1. Special Parking Regulations

There are basically three special parking options available which would allow the reduction of the required number of parking spaces. These options are: shared parking, remote parking and packed parking.

These options are fully described in the Dallas Development Code, Division 51A-4.320.

a. Shared Parking

Shared parking is the use of the same off-street parking stall(s) to satisfy the off-street parking requirements for two or more uses. The uses sharing the parking must have either mutually exclusive or compatibly overlapping normal hours of operation.

Shared parking allows an exception to the requirement that no off-street parking space for one use be included in the calculation of the parking space required for any other use.

b. Remote Parking

Remote parking is off-street parking provided on a lot not occupied by the main facility. It must be located within a walking distance of 300 feet. Remote Parking allows an exception to the requirement that all off-street parking be provided on the lot occupied by the main use facility.

c. Packed Parking

Packed Parking is off-street parking that allows maximal parking on a lot when an attendant is provided to park vehicles. A special parking license and proper signage are also required.

2. Procedures for Special Parking Approval

All Special Parking must be approved by the Building Official. The applicant seeking approval of Special Parking must submit an application to the Building Official for approval. The Dallas City Code, Sections 51A-4.323 through 51A-4.331 describe the details of the approval process.

B. HANDICAPPED PARKING SPACES

1. General

The design of handicapped parking spaces must be in accordance with the “Texas Accessibility Standards (TAS)”. It is the policy of the City of Dallas and the State of Texas to encourage and promote the rehabilitation of handicapped or disabled citizens and to eliminate unnecessary barriers encountered by aged, handicapped, or disabled persons, whose ability to engage in gainful occupation or to achieve maximum personal independence is needlessly restricted when such persons cannot readily use buildings otherwise accessible to the general public.

The Dallas City Code, Section 51A-4.305 provides regulations on handicapped parking. These regulations are based on TAS requirement. In case of any discrepancy, the TAS requirements are applicable.

2. Number of Required Handicapped Parking Spaces

The appropriate number of handicapped parking spaces should be based on the location and function of the building or facilities the parking is to serve but not less than the number specified in the following table in accordance with TAS:

Total Parking in Lot	Req'd. Min. No. of Accessible Spaces	Total Parking in Lot	Req'd. Min. No. of Accessible Spaces
1 to 25	1	201 to 300	7
26 to 50	2	301 to 400	8
51 to 75	3	401 to 500	9
76 to 100	4	501 to 1000	2 percent of total
101 to 150	5	1001 and over	20 plus 1 for each 100 over 1000
151 to 200	6		

3. **Location of Handicapped Parking Space**

Accessible parking spaces and accessible passenger loading zones that serve a particular building should be located on an accessible circulation route and as near as reasonably possible to the accessible primary entries of the building or facility to serve the handicapped.

In multi-level parking garages, remote lots, overhead walkways, handicapped parking spaces shall be located on the shortest possible circulation route.

4. **Specifications of Handicapped Parking Space**

- Head-in or diagonal handicapped parking spaces shall be at least 96 inches wide with an adjacent aisle or clear space of 60 inches wide. In order to accommodate handicapped persons using vans with side lifts, an aisle of 96 inches is preferred (see Figure 11).
- Texas Accessibility Standards (TAS) requires a minimum of 1 designated “van accessible” space for every 8 accessible spaces. Minimum of one “van accessible” space is required.
- An accessible parking space is one that is open on at least one side and allows room for individuals in wheelchairs, crutches, or braces to safely get in and out of a vehicle onto a level surface suitable for wheeling and walking, but not behind and obstructed by parked vehicles.
- Parallel parking is discouraged except when it can be situated in such a manner that handicapped persons entering and exiting vehicles will be out of the flow of traffic (see Figure 10).
- Parking surfaces and accessible aisles shall not have a slope in any direction in excess of 1:50 (2.0%).
- Accessible parking spaces shall be identified and reserved for the handicapped by a sign incorporating the symbol of accessibility and placed so that parked vehicles will not obscure it.

5. **Parking Structures and Remote Lots for the Handicapped**

In instances where parking garages, underground lots, or remote lots are used to serve a particular building or facility, required handicapped parking spaces and conditions shall conform to the following criteria in addition to other specifications contained in the Dallas City Code, Section 51A-4.305:

- There shall be an accessible route from the handicapped parking spaces to the nearest accessible primary entrance to the use.
- Elevators or overhead walkways, if required, shall comply with applicable standards and specifications.

6. **Passenger Loading Zone for the Handicapped**

If passenger loading zone is provided, it should be 13 feet wide and 24 feet long. Barrier-free ramp may also be required for access (see Figure 10).

Handicapped persons entering and exiting vehicles should be kept out of the traffic flow.

C. SMALL OR COMPACT CAR ALLOWANCE

The Dallas Development Code allows that up to 35% of required parking spaces may be allocated to small or compact cars. Refer to Dallas City Code, Section 51A-4.301 (d)(1)(C)(ii).

See Figure 12 for small or compact-car dimensions, and Figure 28 for its striping layout detail requirements.

III. TYPES OF PARKING LAYOUTS

Various forms of parking stall layouts are available for use in a parking lot. Selection of the best parking angle depends primarily on the size and shape of the parking lot.

All parking requires that the stalls closest to the driveway must be placed outside the 20 feet driveway visibility obstruction triangle.

A one-way access lane must be at least 10 feet wide, and a two-way access lane must be at least 20 feet wide.

When an aisle is designated as a fire lane, it must conform to the Dallas Fire Code for minimum aisle size and turning radius.

Table 11 contains the City of Dallas Parking Stall Dimensions as they are listed in the Dallas Development Code, Section 51A-4.301(d)(1)(B). The 7.5-foot wide parking stall is intended for design of compact car spaces only.

A. RIGHT ANGLE PARKING (90°)

In larger lots, placing the stalls at right angles to the aisle provides the most number of parking spaces. The aisle can be used in either direction, and travel distances are reduced.

An example layout for a right angle parking lot is shown in Figure 13.

B. OTHER ANGLES PARKING (30° TO 80°)

Angle parking allows fewer stalls for a given length or aisle than right-angle parking, but is more accessible by self parkers. Another advantage of angle parking is that it permits the use of narrow lot because the stall lengths are variable.

Angle parking requires that the first stall must be placed a minimum of 10 feet from the property line. This is a safety measure to protect occupants of the sidewalk from vehicles backing out of the stall.

Examples of parking lot layouts for various angle parking stalls are shown in Figures 14 through 19.

C. PARALLEL PARKING SPACES

The Dallas City Code 51A-4.301 (d) (1) (A) states that a parking space parallel with the access lane must be 22 feet long and 8 feet wide. At both ends of each row of the parallel parking spaces, 20 feet may be provided for maneuvering.

IV. PROVIDING ADEQUATE CIRCULATION FOR PARKING SPACES

Ease of entry/exit the parking lot and circulation are important to the design success.

Circulation and the parking angle should be matched. One-way aisles may restrict circulation and should be used in pairs. Driver misuse of one-way aisles may be a problem in some situations.

In the design of parking spaces for parking garages, the location of columns is a major factor. Columns should not be closer than 1 foot from the circulation aisle and should not interfere with the door clearance area for the Standard Car as shown in Figure 20.

In providing adequate circulation, the design of parking lots should be coordinated with locations of driveways, any drive-through facilities, and the layout of the parking lot. An appropriate width of aisle should be utilized for Right Angle and/or Angled Parking lots.

Refer to Table 11 for details.

V. DESIGN CONSIDERATIONS FOR PARKING SPACES

A. GEOMETRICS: TURNING RADIUS OF DESIGN VEHICLES

The geometric design of driveways and the layout of parking lots must be based on certain vehicles operating characteristics and vehicle dimensions. The American Association of State Highway and Transportation Officials, 1984, has developed turning templates for ten design vehicles. Four of the design vehicles (passenger car, SU truck, bus and WB-50) are applicable in the design of parking lots and are included in Figures 21 through 24.

The turning templates are used to verify that the geometric layouts for parking lots designed for any of the four vehicles will function well. The passenger car template should be used as a minimum and only for lots where no large vehicles are likely.

The design should also consider the turning characteristics of dumpster/trash trucks and fire trucks. The turning template for the City of Dallas fire truck is show on Figure 25.

B. VISIBILITY TRIANGLES AT DRIVEWAYS, ALLEYS, AND STREET INTERSECTIONS

The visibility triangle affects the layout of parking at the intersection of driveways with alleys and streets; and at the street intersections for corner lots.

According to the Dallas Development Code, Section 51A-4.602(d), a person shall not erect, place, or maintain a structure, berm, plant life, or any other item on a lot if the item is in the "visibility triangle" and is between two and one-half feet and eight feet

in height measured from the top of the adjacent street curb. If there is no adjacent street curb, the measurement is taken from the grade of the portion of the street adjacent to the visibility triangle.

“Visibility triangle” is defined as:

- Portion of a lot within a triangular area formed by connecting together the point of intersection of the edge of a driveway or alley and an adjacent street curb line (or, if there is no street curb, what would be the normal street curb line) and points on the driveway or alley edge and the street curb line 20 feet from the intersection, for all zoning districts.

- Portion of a corner lot within a triangular area formed by connecting together the point of intersection of adjacent street curb lines (or, if there are no street curbs, what would be the normal street curb lines) and points on each of the street curb lines:
 - (a) 45 feet from the intersection in all zoning districts except central area districts, the Deep Ellum/Near Eastside District (Planned Development District No. 269), and the State-Thomas Special Purpose District (Planned Development District No. 225); or
 - (b) 30 feet from the intersection in central area districts, the Deep Ellum/Near Eastside District (Planned Development District No. 269), and the State-Thomas Special Purpose District (Planned Development District No. 225).

Figure 4 shows the dimensions of the visibility triangles for various situations.

C. MATERIALS FOR PARKING SPACES

Refer to Dallas Development Code, Section 51A-4.301(d).

1. Pavement Standards

The surface of the parking lot must be constructed on a compacted subgrade and consist of:

- Concrete paving, or
- Hot mix asphalt paving consisting of a binder and surface course, or
- A material which has equivalent characteristics and approved by the Director of Public Works and Transportation.

2. Wheel Guards

Off-street parking spaces for non-residential uses and parking spaces along the perimeter of a commercial parking lot or garage must have wheel guards not less than 6 inches in height.

The wheel guard or barrier must be at least three feet from the screening or the property line so that no part of a vehicle shall extend onto public sidewalks, or adjoining property. Their placement depends upon the angle for which the parking is planned and the design vehicles used.

Figure 26 illustrates suitable wheel guard and the amount of overhang for both design vehicles at various angles.

3. **Pavement Markings**

Recommended pavement markings are illustrated in Figure 27. Typically, white markings provide the greatest contrast on asphalt lots. On concrete lots, yellow may be preferred.

Figure 28 is a typical striping layout detail for a compact-car parking stall.

D. **DRAINAGE FOR PARKING SPACES**

The parking area should be adequately sloped to minimize the possibility of low or flat spots. The ponding of water in a parking lot is undesirable for both vehicle and pedestrian movement.

If the 100-year peak runoff is less than five (5) cubic feet per second (cfs), with no underground drainage facility and the abutting street has adequate excess drainage capacity, the parking lot should be sloped toward the driveway approach allowing the runoff to be discharged onto the street.

If the 100-year peak runoff exceeds five (5) cfs and/or the abutting street does not have any excess drainage capacity, an underground drainage system with an adequate outfall should be designed to convey the 100-year frequency rainfall runoff.

The drainage plans should be submitted to the Department of Development Services for review and approval.

Since the stormwater runoff ultimately drains onto drainage ditches or creeks, it is important to keep the storm drainage runoff as clean as possible. Therefore, it is highly recommended to use combination curb-grate inlets to intercept the trash as part of any proposed underground storm drainage system. This is especially true in the development of shopping centers and fast-food restaurants.

E. **LIGHTING AND SCREENING FOR OFF-STREET PARKING**

1. **Lighting Provisions for Off-Street Parking**

The lighting of off-street parking lots must meet the minimum requirements described in Section 51A-4.301(e) of the Dallas Development Code.

a. **Lighting Provisions for Commercial Parking Lots**

A commercial parking lot which offers service and collects revenue for use after dark (including attended, self-park, coin-actuated gated lots, and rentals on any basis) must be lighted beginning one-half hour after sunset and continuing throughout the hours of use or until *midnight*, whichever is earlier.

If only a portion of the parking lot is offered for use after dark, only that part must be lighted. However, the portion offered for use must be clearly designated.

b. Lighting Provisions for Other Off-Street Parking

Off-street parking for a use other than single family, duplex, or the commercial parking lot use that offers service after dark must be lighted beginning one-half hour after sunset and continuing throughout the hours of use or until *10 o'clock p.m.*, whichever is earlier.

If only a portion of a parking area is offered for use after dark, only that part must be lighted. However, the portion offered for use must be clearly designated.

2. Screening Provisions for Off-Street Parking

The owner of off-street parking must maintain the screening in compliance with standards set forth in Section 51A-4.301(f) of Dallas Development Code.

Screening for off-street parking must be a brick, stone, concrete masonry, stucco, concrete, or wooden wall or fence that is not less than six feet in height. The wall or fence may not have more than ten square inches of open area for each square foot of surface area, and may not contain any openings or gates for vehicular access.

VI. CONSTRUCTION AND MAINTENANCE OF PARKING SPACES

Refer to Dallas Development Code, Section 51A-4.301(d).

A. CONSTRUCTION OF PARKING SPACES

1. Single Family or Duplex Use

For a single family or duplex use, the surface of a parking space, maneuvering area for parking, or driveway must consist of an all-weather and drainable material which is approved by the building official, or a material specified in the following Subsection 2 "Other Uses".

2. Other Uses

For a use other than a single family or duplex use, the surface of an enclosed or unenclosed parking space, maneuvering area for parking, or a driveway which connects to a street or alley must be constructed on a compacted sub-grade, and must consist of:

- Concrete paving; or
- Hot mix asphalt paving which consists of a binder and a surface course; or
- Material which has equivalent characteristics and has the approval of the Building Official.

B. MAINTENANCE OF PARKING SPACES

The owner of off-street parking for a use other than single family or duplex use must:

- Keep the parking surface free of potholes; and
- Maintain wheel guards and barriers; and
- Maintain non-permanent parking space markings such as paint, so that clear identification of each parking space is apparent; and
- Keep the parking lot clean.

* * *

*

TABLE 1 – SPACING BETWEEN DRIVEWAYS, MIN. PROPERTY CLEARANCE

Functional Classification	DESIRABLE Spacing between Driveways	MINIMUM Spacing between Driveways	Minimum Property Clearance Distance
ARTERIAL(Principal)	200'	20' normally See Fig. 1	10'
ARTERIAL(Minor)	20'	20' normally See Fig. 1	10'
COLLECTOR (Community)	150'	14' normally See Fig. 1	7'
COLLECTOR (Residential)	20'	14' normally See Fig. 1	7'* 5'***
LOCAL (Residential)	20'	14' normally See Fig. 1	7'* 5'***

NOTES :

- * 7' for driveway with dustpan turnout, 5' min. for driveway width of 15' or greater
(The distance is measured from the edges of driveway throat).
- ** 5' for driveway with radius turnout.

TABLE 2 - CLEARANCE DISTANCE TO INTERSECTION FOR DRIVEWAYS

Street abutted by Driveway	Intersecting with	MINIMUM Clearance Distance	DESIRABLE Clearance Distance
Arterial	Arterial	See Fig. 2	250'
Arterial	Collector	See Fig. 2	125'
Arterial	Local	See Fig. 2	50'
Collector	Any	See Fig. 2	50'
Local	Any	See Fig. 2	50'

TABLE 3 - D-VALUE FOR USE WITH FIGURE 2 CLEARANCE DISTANCE TO INTERSECTION FOR DRIVEWAYS

ARTERIAL DESIGN SPEED (MPH)	D-VALUE (feet) CLEARANCE DISTANCE TO INTERSECTION FOR DRIVEWAYS		
	Percent of Right Turns		
	<10%	10%-20%	>20%
35	30'	40'	50'
40	35'	50'	60'
45	40'	55'	65'
50	45'	60'	70'
55	75'	80'	85'

TABLE 4- STOPPING AND INTERSECTION SIGHT DISTANCES

Design Speed MPH	Street Section Type ***	Stopping Sight Distance (Feet)		Intersection Sight Distance (Feet)			
		Min.	Desirable	Left Side		Right Side	
				Min.	Desirable	Min.	Desirable
25	L-2-U(B)	150	200	110	235	150	240
25	L-2-U(A)	150	200	110	235	150	240
30	M-2-U	200	200	145	315	200	315
30	S-2-U	200	200	145	315	200	315
35	M-2-U	225	250	180	405	225	410
35	S-2-U	225	250	180	405	225	410
35	M-4-U*	225	250	180	405	225	410
40	M-2-U	275	315	225	485	275	485
40	S-2-U	275	315	225	485	275	485
40	M-4-U*	275	315	225	485	275	485
40	M-4-U	275	315	225	485	275	485
40	M-4-D(B)	275	315	225	485	275	500
45	M-4-U couplet	325	385	270**	575**	270**	575**
45	S-4-U	325	385	270	575	325	580
45	M-4-D(A)	325	385	270	575	325	595
45	M-6-D(B)	325	385	270	575	325	610
45	M-3-U couplet	325	385	270**	575**	270**	575**
45	S-4-U couplet	325	385	270**	575**	270**	575**
45	S-3-U couplet	325	385	270**	575**	270**	575**
50	S-4-D	400	460	325	675	400	700
50	M-6-D(B)	400	460	325	675	400	705
50	M-6-D(A)	400	460	325	675	400	710
55	M-6-D(B)	450	540	375	780	450	815
55	M-6-D(A)	450	540	375	780	450	820
55	S-6-D	450	540	375	780	450	825
55	S-8-D	450	540	375	780	450	840

NOTES :

* Striped for four lanes

** Applicable for oncoming traffic side on one-way couplet

*** For street section types, see Paving Design Manual, June 1998, Section II, Table II-4, "Street and Thoroughfare Geometric Standards"

For distance adjustment due to grade of street, use Table 5

TABLE 5- SIGHT DISTANCE ADJUSTMENTS DUE TO GRADE

Design Speed (MPH)	Upgrades (Decrease) in Feet			Downgrades (Increase) in Feet		
	3%	6%	9%	3%	6%	9%
25	4	8	10	5	15	25
30	6	10	20	10	20	30
35	8	15	25	15	30	50
40	10	20	30	20	40	70
45	15	25	40	25	50	95
50	20	30	50	30	70	120
55	25	40	60	40	90	145

TABLE 6 – ENTRY WIDTHS OF DRIVEWAYS

Curb Return Radius (feet)	ENTRY WIDTHS OF DRIVEWAYS (feet *)		
	P (Passenger Car)	SU (Single-Unit Truck)	WB-50 (Semi-Trailer Truck)
5 **	15	-	-
10	12	34	-
15	11	30	-
20	-	26	-
25	-	22	34
30	-	18	30

NOTES :

- * for 90-degree entry on ARTERIALS and COLLECTOR THOROUGHFARES.
- ** for use on LOCAL STREETS only.

TABLE 7 – DECELERATION LANE LENGTH INCLUDING TAPER

STREET FUNCTIONAL CLASSIFICATION	DECELERATION LANE LENGTH (feet)
Arterial	350
Collector	250
Local	200

TABLE 8 – PAVEMENT WIDTHS FOR TURNING ROADWAYS

Radius of Inner Edge of Pavement	Recommended Pavement Width for Design Vehicle		
	Passenger Car	Single Unit Truck	Semi-Trailer Truck
50'	14'	18'	26'
75'	14'	17'	22'

TABLE 9 – VEHICLE STORAGE LENGTHS FOR DRIVEWAY EGRESS

Parking Spaces per Egress Lane	VEHICLE STORAGE LENGTH * (feet, measured from property line)			
	MF Residential	Retail	Office	Industrial
0 - 200	20	20	20	50
201 - 400	20	20	80	150
401 - 600	40	120	160	More lanes
601 - 700	80	160	More lanes	More lanes
over 700	160	More lanes	More lanes	More lanes

* At point of major ingress/ egress, the length of the storage is minimum of 60 feet.
Rev2 – Jan 2005

**TABLE 10 – DRIVEWAY PROFILE, STANDARDS FOR GRADES
(see Figure 7)**

	Minimum G2	Maximum G2
Low Volume Driveway* on Local Street	-10%	10%
Low Volume Driveway* on Collector Thoroughfare	-4%	8%
Low Volume Driveway* on Arterial	-1%	5%
High Volume Driveway** on any Street	-1%	5%

NOTES :

- * Low Volume Driveway – a driveway with less than 100 vehicles in the peak hour in the peak direction.
- ** High Volume Driveway – a driveway with more than 100 vehicles in the peak hour in the peak direction.

TABLE 11 - PARKING BAY WIDTH

		7.5' STALL WIDTH x 16'					8.5' STALL WIDTH x 18'					
		B										
Parking Angle	AISLE		ONE ROW		TWO ROWS		AISLE		ONE ROW		TWO ROWS	
	ONE WAY	TWO WAY	ONE WAY	TWO WAY	ONE WAY	TWO WAY	ONE WAY	TWO WAY	ONE WAY	TWO WAY	ONE WAY	TWO WAY
A	D		Y1		Y2		D		Y1		Y2	
30	12.0'	18.0'	26.5'	32.5'	41.0'	47.0'	11.1'	20.0'	27.5'	36.4'	43.9'	52.8'
40	12.0'	18.0'	28.0'	34.0'	44.0'	50.0'	11.4'	20.0'	29.5'	38.1'	47.6'	56.2'
50	12.0'	18.0'	29.1'	35.1'	46.2'	52.2'	12.7'	20.0'	32.0'	39.3'	51.3'	58.6'
60	14.0'	18.0'	31.6'	35.6'	49.2'	53.2'	15.2'	20.0'	35.0'	39.8'	54.8'	59.6'
70	15.0'	18.0'	32.6'	35.6'	50.2'	53.2'	18.2'	20.0'	38.0'	39.8'	57.8'	59.6'
80	18.0'	18.0'	35.1'	35.1'	52.2'	52.2'	21.8'	21.8'	41.0'	41.0'	60.2'	60.2'
90	18.0'	18.0'	34.0'	34.0'	50.0'	50.0'	24.0'	24.0'	42.0'	42.0'	60.0'	60.0'
		9.0' STALL WIDTH x 18'					10.0' STALL WIDTH x 18'					
		B										
Parking Angle	AISLE		ONE ROW		TWO ROWS		AISLE		ONE ROW		TWO ROWS	
	ONE WAY	TWO WAY	ONE WAY	TWO WAY	ONE WAY	TWO WAY	ONE WAY	TWO WAY	ONE WAY	TWO WAY	ONE WAY	TWO WAY
A	D		Y1		Y2		D		Y1		Y2	
30	10.7'	20.0'	27.5'	36.8'	44.3'	53.6'	9.3'	20.0'	27.0'	37.7'	44.7'	55.4'
40	11.0'	20.0'	29.5'	38.1'	47.6'	56.9'	9.3'	20.0'	28.5'	39.2'	47.7'	58.4'
50	11.4'	20.0'	31.0'	39.8'	50.6'	59.2'	9.9'	20.0'	30.1'	40.2'	50.3'	60.4'
60	14.0'	20.0'	34.0'	40.0'	54.0'	60.0'	10.4'	20.0'	31.0'	40.6'	51.6'	61.2'
70	17.0'	20.0'	37.0'	40.0'	57.0'	60.0'	13.7'	20.0'	34.0'	40.3'	54.3'	60.6'
80	19.7'	20.0'	39.0'	39.3'	58.3'	58.6'	17.5'	20.0'	37.0'	39.5'	56.5'	59.0'
90	22.0'	22.0'	40.0'	40.0'	58.0'	58.0'	20.0'	20.0'	38.0'	38.0'	56.0'	56.0'

NOTES :

Refer to Figures 13 thru 19

TYPE APPLICATION

- PERMIT CO
 OTHER _____



CITY OF DALLAS BUILDING INSPECTION APPLICATION

DATE		USE OF PROPERTY			ADDRESS OF PROPOSED PROJECT																																																																
OWNER/TENANT			ADDRESS			CITY		STATE	ZIP																																																												
DBA (IF APPLICABLE)																																																																					
APPLICANT(PRINT)			CONTR.#	SSN# OR PIN# (IF APPLICABLE)			COMPANY NAME																																																														
ADDRESS			CITY	STATE	ZIP	PHONE#		FAX#																																																													
DESCRIPTION OF PROPOSED PROJECT					SQ.FT.	NEW SQ FT		VALUE	NEW CONST \$																																																												
						REMODEL SQ FT			REMODEL \$																																																												
						LEASE			TOTAL \$																																																												
						TOTAL																																																															
PLEASE INDICATE ALL TYPES OF WORK THAT WILL BE PART OF THIS PROJECT BY CHECKING THE APPROPRIATE CIRCLE AND PROVIDE CONTRACTOR/SUBCONTRACTOR INFORMATION ON THE BACK OF THIS FORM FOR THIS PROJECT.																																																																					
<input type="radio"/> BUILDING		<input type="radio"/> PLUMBING		<input type="radio"/> LAWN SPRINKER		<input type="radio"/> FENCE		<input type="radio"/> SWIMMING POOL																																																													
<input type="radio"/> ELECTRICAL		<input type="radio"/> FIRE SPKLR		<input type="radio"/> FLAMM LIQUID		<input type="radio"/> BARRICADE		<input type="radio"/> FIRE ALARM																																																													
<input type="radio"/> MECHANICAL		<input type="radio"/> LANDSCAPE		<input type="radio"/> DRIVE APPROACH		<input type="radio"/> SIGN		<input type="radio"/> OTHER _____																																																													
WILL YOU SELL/SERVE ALCOHOL? <input type="radio"/> YES <input type="radio"/> NO					DO YOU HAVE A DANCE FLOOR? <input type="radio"/> YES <input type="radio"/> NO																																																																
I HAVE CAREFULLY READ THE COMPLETED APPLICATION AND KNOW THE SAME IS TRUE AND CORRECT AND HEREBY AGREE THAT IF A PERMIT IS ISSUED ALL PROVISIONS OF THE CITY ORDINANCES AND STATE LAWS WILL BE COMPLIED WITH WHETHER HEREIN SPECIFIED OR NOT. I AM THE OWNER OF THE PROPERTY OR THE DULY AUTHORIZED AGENT. PERMISSION IS HEREBY GRANTED TO ENTER PREMISES AND MAKE ALL INSPECTIONS.								APPLICANT SIGNATURE																																																													
BELOW FOR OFFICE USE ONLY																																																																					
and Use	Type Work	Act.	Own.	Occ	Block		Lot	Base Zoning																																																													
Pd.	SUP.	DR.	FP.	Dry	Hist.	Type Const.	Req. Park	Pro Park																																																													
Lot Area			Spkter.	Bdrm.	Bath	Dw. Units	Stones	BDA																																																													
Prkg. Agrmt.	Early Release	RAR		DIR	Spec. Inspec.	LL	Airpt.																																																														
REMARKS:																																																																					
<table border="1" style="width:100%; border-collapse: collapse;"> <thead> <tr> <th>ROUTE TO</th> <th>CH'KD</th> <th>DATE</th> <th>COMMENTS</th> </tr> </thead> <tbody> <tr><td>PRE-SCREEN</td><td></td><td></td><td></td></tr> <tr><td>PRE-INSP</td><td></td><td></td><td></td></tr> <tr><td>ZONING</td><td></td><td></td><td></td></tr> <tr><td>BUILDING</td><td></td><td></td><td></td></tr> <tr><td>ELECTRICAL</td><td></td><td></td><td></td></tr> <tr><td>PLUMB/MECH</td><td></td><td></td><td></td></tr> <tr><td>HISTORICAL</td><td></td><td></td><td></td></tr> <tr><td>PUB. WORKS</td><td></td><td></td><td></td></tr> <tr><td>WATER</td><td></td><td></td><td></td></tr> <tr><td>HEALTH</td><td></td><td></td><td></td></tr> <tr><td>FIRE</td><td></td><td></td><td></td></tr> <tr><td>AVIATION</td><td></td><td></td><td></td></tr> <tr><td>LANDSCAPE</td><td></td><td></td><td></td></tr> <tr><td>OTHER</td><td></td><td></td><td></td></tr> </tbody> </table>					ROUTE TO	CH'KD	DATE	COMMENTS	PRE-SCREEN				PRE-INSP				ZONING				BUILDING				ELECTRICAL				PLUMB/MECH				HISTORICAL				PUB. WORKS				WATER				HEALTH				FIRE				AVIATION				LANDSCAPE				OTHER				FORM #1				
					ROUTE TO	CH'KD	DATE	COMMENTS																																																													
					PRE-SCREEN																																																																
					PRE-INSP																																																																
					ZONING																																																																
					BUILDING																																																																
					ELECTRICAL																																																																
					PLUMB/MECH																																																																
					HISTORICAL																																																																
					PUB. WORKS																																																																
					WATER																																																																
					HEALTH																																																																
FIRE																																																																					
AVIATION																																																																					
LANDSCAPE																																																																					
OTHER																																																																					
					FEE CALCULATIONS																																																																
					PERMIT FEE																																																																
					SURCHARGE																																																																
					PLAN REV.																																																																
					POSTAGE																																																																
OTHER FEES																																																																					
					TOTAL FEE																																																																

For Fax Customers Only
 Credit Card Type
 Please Circle
VISA MASTERCARD AMEX
CARTE BLANCHE DINERS CLUB
 Credit Card Number:
 # _____
 Customer No. _____
 Expiration Date. _____
 Billing Zip Code: _____

CITY OF DALLAS PAVING BOND FORM



THE STATE OF TEXAS) KNOW ALL MEN BY THESE PRESENTS:

COUNTY OF DALLAS)

THAT WE, _____, AS PRINCIPAL, AND _____, AS SURETY,

HEREBY ACKNOWLEDGE OURSELVES HELD AND FIRMLY BOUND AND PROMISE TO PAY TO THE CITY OF DALLAS, A MUNICIPAL CORPORATION, THE SUM OF TWO THOUSAND DOLLARS AND NO/100 (\$2,000.00) FOR THE PAYMENT OF WHICH AT DALLAS, DALLAS, COUNTY, TEXAS WELL AND TRULY TO BE MADE, WE BIND OURSELVES, OUR HEIRS, EXECUTORS, ADMINISTRATORS, SUCCESSORS AND ASSIGNS JOINTLY AND SEVERALLY.

THE CONDITION OF THIS OBLIGATION IS SUCH THAT :

WHEREAS, THE ABOVE BOUNDEN PRINCIPAL IS ENGAGED IN THE BUSINESS OF CONSTRUCTION, RECONSTRUCTION AND REPAIR OF SIDE WALKS, CURBS, GUTTERS OR DRIVEWAY APPROACHES IN THE CITY OF DALLAS AND DESIRES TO CONTINUE SO TO DO. NOW THEREFORE, IF THE IS SAID PRINCIPAL SHALL DO ALL IN THE CONSTRUCTION, RECONSTRUCTION AND REPAIR OF THE SIDEWALKS, CURBS, GUTTERS OR DRIVEWAY APPROACHES IN A GOOD WORKMANLIKE MANNER AND SHALL IN THE CONSTRUCTION, RECONSTRUCTION AND REPAIR OF SIDEWALKS, CURBS, GUTTERS OR DRIVEWAY APPROACHES, STRICTLY COMPLY WITH THE SPECIFICATIONS PRESCRIBED BY THE CITY OF DALLAS AND ANY AMENDMENTS THAT MAY BE MADE THERETO, AND WITH TERMS AND PROVISIONS OF ALL ORDINANCES, RESOLUTIONS AND REGULATIONS OF THE CITY OF DALLAS NOW IN FORCE, OR THAT MAY BE MADE HERE AFTER PASSED, BY THE CITY COUNCIL OF THE CITY OF DALLAS, GOVERNING AND RELATING TO THE CONSTRUCTION, RECONSTRUCTION AND REPAIR OF SIDEWALKS, CURBS, GUTTERS OR DRIVEWAY APPROACHES, AND IF THE SAID PRINCIPAL SHALL FULLY INDEMNIFY AND HOLD WHOLE AND HARMLESS THE CITY OF DALLAS FROM ANDY AND ALL COSTS, EXPENSE AND OR DAMAGE, REAL OR ASSERTED ON ACCOUNT OF ANY INJURY DONE TO ANY PERSON OR PROPERTY IN THE PROSECUTION OF SAID WORK, FURTHER, IF THE SAID PRINCIPAL SHALL, WITHOUT ADDITIONAL COST TO ANY PERSON, FIRM OR CORPORATION FOR WHOM ANY SUCH WORK IS DONE, MAINTAIN WALKS, CURBS, GUTTERS OR DRIVEWAY APPROACHES SO CONSTRUCTED, RECONSTRUCTED OR REPAIRED BY THE SAID PRINCIPAL FOR A PERIOD OF FIVE (5) YEARS FROM THE DATE SUCH CONSTRUCTION, RECONSTRUCTION, OR REPAIR, TO THE SATISFACTION OF THE DIRECTOR OF PUBLIC WORKS OF THE CITY OF DALLAS AS THE NECESSITY FOR SUCH RECONSTRUCTION OR REPAIR BEING CONCLUSIVE AND BINDING ON THE PARTIES THERETO, THEN THIS OBLIGATION SHALL BECOME NULL AND VOID; OTHERWISE, IT SHALL REMAIN IN FULL FORCE AND EFFECT.

THIS OBLIGATION SHALL EXPIRE ON JANUARY 1, 2004, BUT AS TO THE MAINTENANCE OBLIGATION ON EACH JOB CONSTRUCTION, RECONSTRUCTION OR REPAIR OF SIDEWALKS, CURBS, GUTTERS OR DRIVEWAY APPROACHES, THIS OBLIGATION SHALL CONTINUE FROM DATE OF COMPLETION OF SAME FOR A PERIOD OF FIVE (5) YEARS, RECOURSE ON THIS OBLIGATION MAY BE HAD BY THE CITY OF DALLAS OR BY ANY PERSON, FIRM OR CORPORATION FOR WHOM ANY WORK OF CONSTRUCTION, RECONSTRUCTION, OR REPAIR OF SIDEWALKS, CURBS, GUTTERS OR DRIVEWAY APPROACHES IS DONE BY THE SAID PRINCIPAL; AND WHO MAY BE AGGRIEVED RO INJURED BY A BREACH OF ANY THE FORGOING CONDITIONS, AND THIS OBLIGATION SHALL BE A CONTINUING ONE AGAINST THE PRINCIPAL AND SURETY HEREON AND SUCCESSIVE RECOVERIES MAY BE HAD FOR SUCCESSIVE BREACHES, UNTIL THE ENTIRE AMOUNT SHALL HAVE BEEN EXHAUSTED. IF ANY LEGAL ACTION BE FILLED UPON THIS BOND, VENUE SHALL LIE IN DALLAS COUNTY, TEXAS.

WITNESS OUR HANDS THIS THE _____ DAY OF _____ A.D. 20_____.

PRINCIPAL (PRINT) _____ ADDRESS _____.

BY: (SIGNATURE) _____ CITY _____ ST _____ ZIP _____

RESIDENT AGENT SURETY: _____

NAME _____ ADDRESS _____ CITY _____ ST _____ ZIP _____

..... CONTRACTOR # _____ EXPIRES _____ APPROVED _____

WHERE TO FIND PLANS FOR CITY FACILITIES

PW&T Storm Sewer, PW&T Vault / 214-948-4149, OCMC # 314
 PW&T Projects, Vince Thill / 214-948-4042, OCMC #312
 PW&T Traffic Signal Constr, Jim Easler/ 214-670-3896, 3204
 Canton
 DWU Water, Eddie Gifford / 214-948-4584, OCMC # 215
 DWU Wastewater, Eddie Gifford / 214-948-4584, OCMC # 215



Permit Review/ Approval No.

(for city use only)

City of Dallas
 Attn: Utility Coordinator
 320 E. Jefferson Blvd., #312
 Dallas, TX 75203

PERMIT APPLICATION	
FOR REVIEW & APPROVAL OF ANY CONSTRUCTION ACTIVITY WITHIN THE RIGHT OF WAY	
(Articles VIII and IX of Chapter 43, "Streets and Sidewalks," of the Dallas City Code)	
Date of Application: _____ <input type="checkbox"/> EMERGENCY <input type="checkbox"/> NON-EMERGENCY	
<i>(PLEASE CHECK ALL APPLICABLE)</i>	
<input type="checkbox"/> Public Service Provider Are you registered w/ City of Dallas? Yes ___ No ___ (If Yes, you <u>do not</u> need to provide another proof of insurance)	<input type="checkbox"/> Long Distance Carrier <input type="checkbox"/> Governmental Entity or Agency (other than City of Dallas) <input type="checkbox"/> Contractor <input type="checkbox"/> Other _____
{ Is this project crossing the right of way of other Governmental Entities or Agencies? Yes ___ No ___ If Yes, please check all applicable: <input type="checkbox"/> TxDOT <input type="checkbox"/> NTTA <input type="checkbox"/> County(s): _____ <input type="checkbox"/> City(s): _____ <input type="checkbox"/> Other _____	
{ Do you have a document of approval from each above entity or agency? Yes ___ (please attach) No ___	
{ Is this project crossing or utilizing private property, including abandoned streets? Yes ___ No ___ Do you have a letter of permission from the owner(s)? Yes ___ (please attach) No ___ } Your application will not be processed until receipt of above document(s)	
HAVE YOU ATTACHED THE FOLLOWING ITEMS WITH YOUR SUBMITTAL?:	
1. 3 sets of plans, prepared per section 43-139 (c) (5) of the City Code <i>(To be submitted w/ cover letter from Owner of facility, requesting plan review)</i>	Yes ___ No ___
2. Proof of Insurance as required per section 43-140 of the City Code	Yes ___ No ___
A) Name of the Company that owns the facilities to be constructed: _____	
B) Project Name: _____	
C) Permittee's Name: First: _____ Middle: _____ Last: _____	
D) Permittee's Company Name: _____ Address: _____	
E) Permittee's: Telephone No. _____ Cellular No. _____ Fax No. _____ E-mail Address _____	
F) State name and address of owner of facilities upon completion of construction: Name: _____ Address: _____ Contact Name: _____ Tel. No. _____ E-mail: _____	
G) Permittee's Statement: _____ (print Permittee's Company Name) representatives have collected all available plans for existing City of Dallas underground facilities and other public and private utilities, and have included them in our design, showing no apparent conflict. Further Permittee affirms that _____ (print Permittee's Company Name) will perform field verifications as necessary during construction to locate all city and other existing underground facilities. Permittee's Name (print) _____ Signature: _____	
FOR CITY USE ONLY Permit Approved by City of Dallas : Yes ___ No ___ Name: _____ Title: Utility Coordinator Signature: _____ Date: _____	Comments:
H) If this permit is approved, please complete a "Street Excavation Data Form", (for copies call 214-948-4445), attach it to this form and fax both forms to: PW&T Cut Control Section at: 214-948-4030	

WHERE TO FIND PLANS FOR CITY FACILITIES

PW&T Storm Sewer, Vault / 214-948-4149, OCMC # 314
DWU Water, Eddie Gifford / 214-948-4584, OCMC # 215
DWU Wastewater, Eddie Gifford / 214-948-4584, OCMC # 215



Permit Review/ Approval No.

[Empty box for Permit Review/ Approval No.]

(for city use only)

City of Dallas
Attn: Utility Coordinator
320 E. Jefferson Blvd., #312
Dallas, TX 75203

PERMIT APPLICATION (Short Form)
FOR REVIEW & APPROVAL OF ANY CONSTRUCTION ACTIVITY WITHIN THE RIGHT OF WAY
(Articles VIII and IX of Chapter 43, "Streets and Sidewalks," of the Dallas City Code)

Date of Application: _____ System Subscriber Non-Subscriber

A) Name of the Owner that is requesting this permit: _____

Address: _____

Telephone No. _____ Fax No. _____

B) Applicant's Representative: _____

Telephone No. _____ Fax No. _____

(If applicable)

C) Contractor's Name: _____

Address: _____

Telephone No. _____ Cellular No. _____ Fax No. _____

D) Project Location/Address: _____

Mapsco # _____ Reason for Permit: _____

E) Number of Cuts _____ Excavation Area _____ Ft. X _____ Ft.

Type of surface: Concrete Asphalt Other

Type of Improvement: Street Sidewalk Alley Other

Direction of Cut to Traffic Lanes: Crossing Parallel Bore

Lanes Closed to Traffic _____

F) Start Date _____ Est. Completion Date _____

Owner's Name (print) _____ Signature: _____

FOR CITY USE ONLY

Permit Approved by City of Dallas : Yes No

Name: Vince Thill, Utility Coordinator

Signature: _____ Date: _____

Comments:

**CITY OF DALLAS
STREET EXCAVATION DATA FORM**

PERMIT NUMBER

EFFECTIVE DATE

JOB LOCATION:

Address Intersection From-To

Mapscop Page: _____

Front Rear Side

Is excavation part of a planned project previously approved by the City?

No Yes (If Yes, list reference #)

JOB DESCRIPTION: Excavation Depth

More/ Less than 1 foot

Excavation Area - _____ Ft. X _____ Ft.

Number of Cuts - _____

Type of Surface

Concrete Asphalt Other

Type of Improvement

Street Sidewalk Alley

Median Parkway

Direction of Cut to Traffic Lanes

Crossing Parallel Bore

Lanes Closed to Traffic

0 (Zero) 1 (One) 2 (Two)

3 (Three) 4 (Four) 5 or More

Entire Street

START DATE _____

EST. COMPLETION DATE _____

EMERGENCY NON-EMERGENCY

APPLICANT:

System Subscriber (Skip to "Applicant's Representative")

Non-Subscriber

Name _____

Address _____

Phone _____

APPLICANT'S REPRESENTATIVE:

Name _____

Phone _____

CONTRACTOR:

Name _____

Address _____

Phone _____

Emergency Phone No. _____

REASON FOR JOB: New Service

New Line or Multiple Adjustments

Repair Existing Service

Stop Service or Abandon Line

Exploration Adjustment

COMMENTS: _____

c0043 - 10/15/2003 - 006 - 10/15/03

PERMIT NUMBER EFFECTIVE DATE

EMERGENCY NON-EMERGENCY

APPLICANT:

System Subscriber

Non-Subscriber:

(Subscribers leave the following four lines blank)

Name Cut Control

Address 320 E. Jefferson

Dallas, Texas 75202

Phone 214 948-4445 ext.

APPLICANT'S REPRESENTATIVE:

Name Mik

Phone 281 361-0663 ext.

CONTRACTOR:

Emergency Phone 678 864

Name ENT

Address 5252 Westchester Ste. 250

Houston, Texas 77005

Phone 713 666-6223 ext.

Bond #

Expiration date 1/1/1900

REASON FOR JOB: New Service

New Line or Multiple Adjustments

Repair Existing Service

Stop Service or Abandon Line

Exploration

Adjustment

Base Repair

COMMENTS SUBSCRIBER: HEAT TREATMENT SERVICES, INC. 281-361-0663



CITY OF DALLAS

STREET EXCAVATION PERMIT

JOB LOCATION:

Address Intersection From - To

3000-3200 PEORIA AV

Mapsc0: 42 R District: 2

Front Rear Side

IS EXCAVATION PART OF A PLANNED PROJECT PREVIOUSLY APPROVED BY THE

CITY? No Yes - If Yes, give reference #:

A0400122

JOB DESCRIPTION: Excavation Depth

More / Less than 1 foot

Excavation Area - 1 Ft. X 1 Ft.

Number of Cuts 16

Type of Surface

Concrete Asphalt Other

Type of Improvement

Street Sidewalk Alley

Median Parkway

Direction of Cut Traffic Lanes

Crossing Parallel Bore

Lanes Closed to Traffic

0 / 1 / 2 / 3 / 4 / 5 or More / Entire Street

START DATE 10/27/03

EST. COMPLETION DATE 11/1/03

EXTENSION DATE #OF EXT

FORM #6

I. HIGH-DENSITY RESIDENTIAL (TH3, TH4, MF, MH, CH) or COMMERCIAL

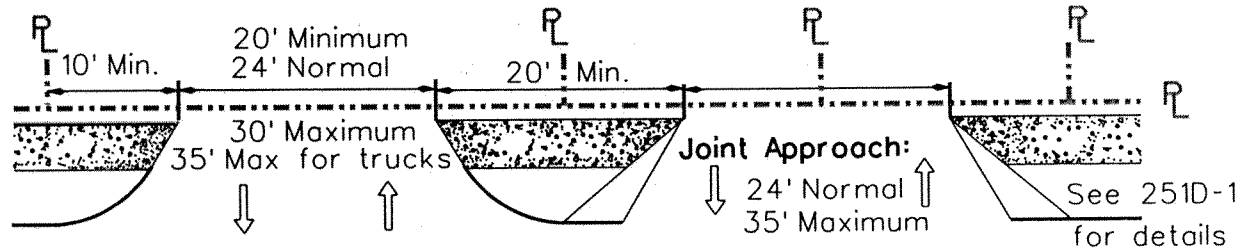

a. Two-Way Operation

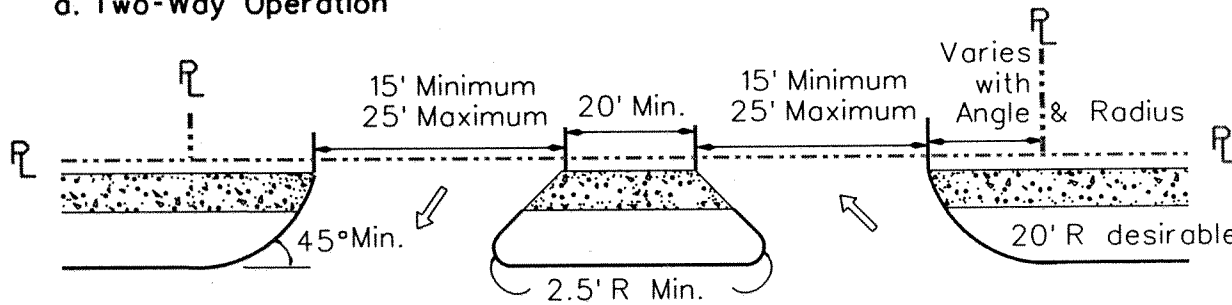

b. One-Way Operation (Angle Approach)

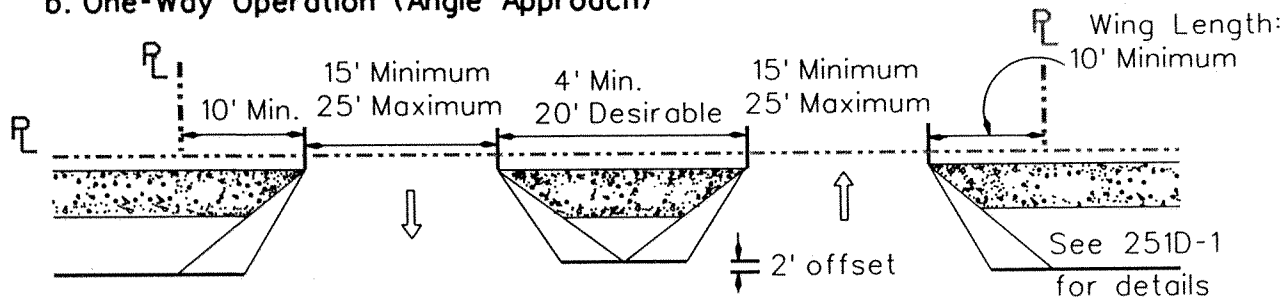

c. One-Way Operation (90° approach)

NOTES:

- 1a. For Driveway Approaches on local and collector streets, use 7' Wing length or R=5' (for driveway width of 15' or greater, use 5' Wing length)
- 1b. For Driveway Approaches on Arterials, use 10' Wing length or R= 10' min.
2. Driveway Spacing 20' min. on Arterials.
3. CBD Driveway Approaches require Special Standards. See Std. Constr. Details, -File 251D-1, page 1007
4. 60' max. width may be used for WB-50 loading docks.

II. LOW- / MEDIUM-DENSITY RESIDENTIAL (R-1 through R-7.5, TH1 and TH2)

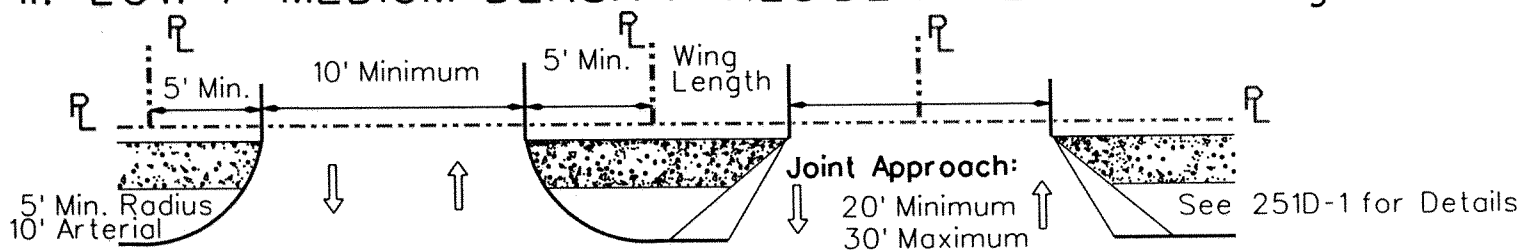

- NOT TO SCALE -

Reference: Fig IV-19 in PWT Paving Design Manual, June 1998

Figure 1: Driveway Standards

Department of Development Services / Engineering Division

I. INTERSECTION WITHOUT FREE-RIGHT-TURN LANE

- A. Arterial at Arterial, Arterial at Community Collector, Arterial at Local St with School / Pedestrian Crosswalks
 1. 90° Driveway Approaches
 2. Angle- or One-Way Approaches

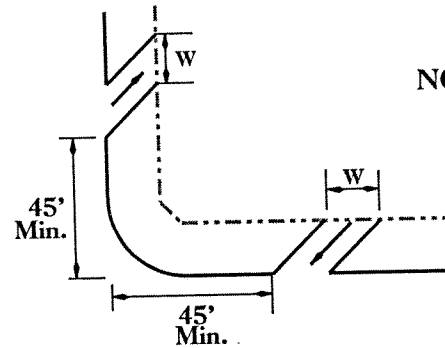
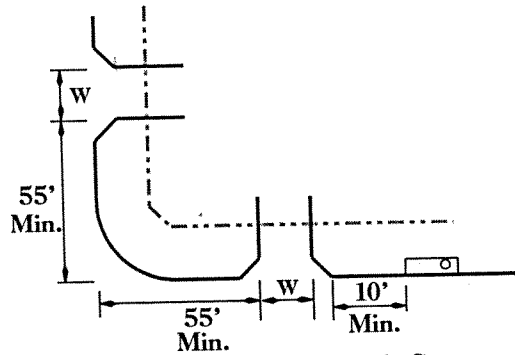

NOTES:

1. For Arterials (both 90° and angle approaches), the location of driveway depends upon speed and percent of free-right-turn traffic volume.
2. For "D" value, see Table 3

- B. Arterial at Residential Collector or at Local Street; Residential Collector at Local Street

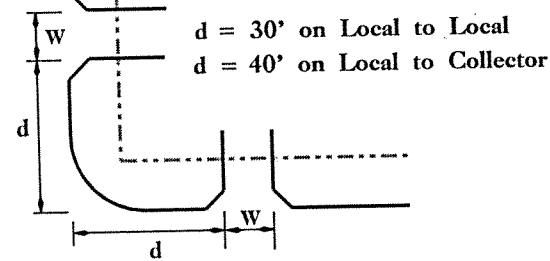
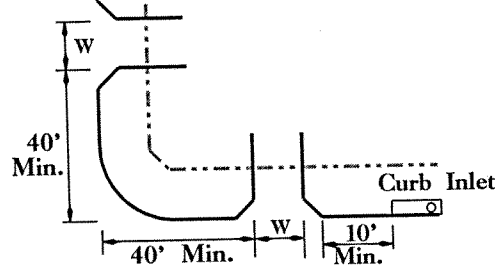

II. INTERSECTION WITH FREE-RIGHT-TURN LANE

- A. without Acceleration or Deceleration lane
 B. with Acceleration or Deceleration lane
 C. with Continuous Flow

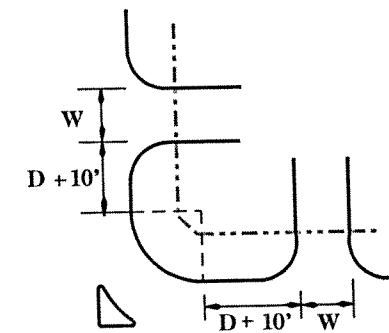
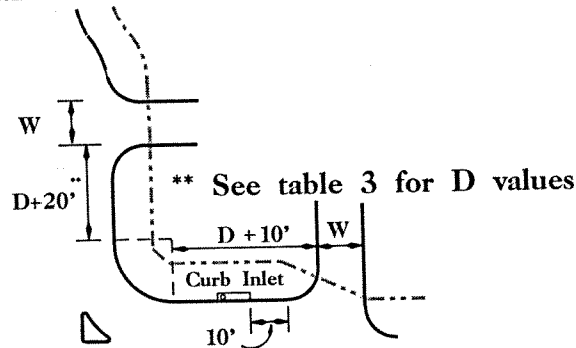
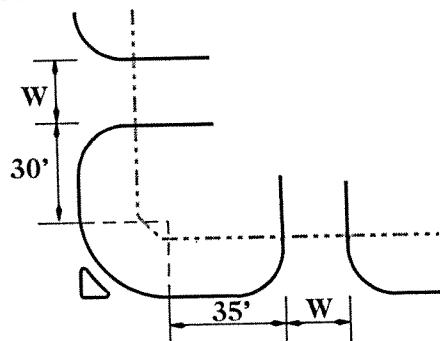

NOTES:

For typical street corner curb return radii, see Plate IV-12, IV-13, and IV-14 of the PW&T Paving Design Manual, June,1998
 For Driveway Flare and Width Standards, see Figure IV-19 of the PW&T Paving Design Manual, June,1998.

Reference: Fig III-2 in PWT Paving Design Manual, June 1998

- Not to Scale-

Figure 2: Minimum Distances from Intersections for Drives

Department of Development Services / Engineering Division



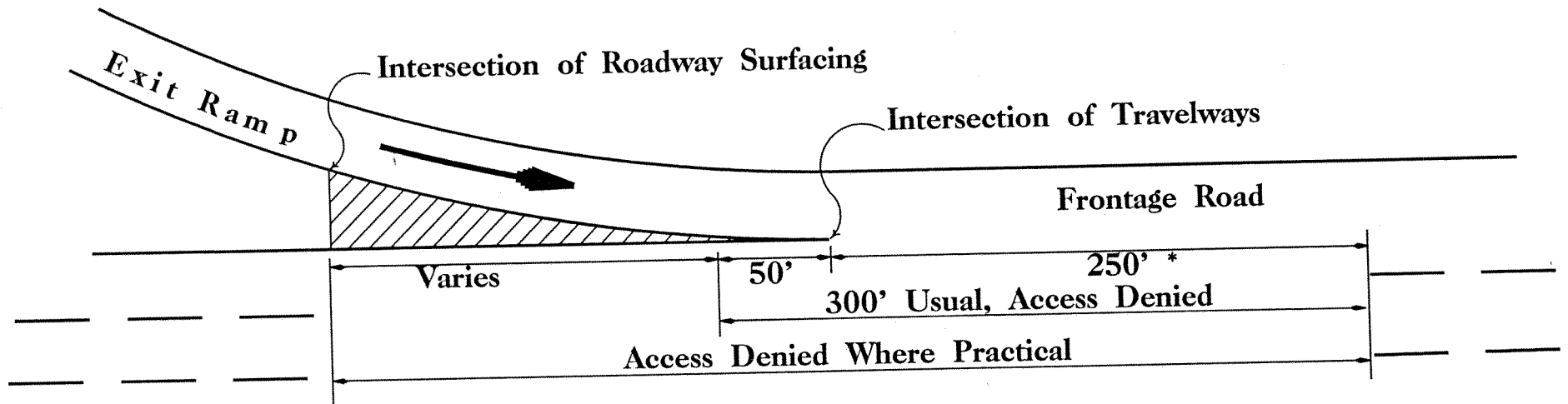

NOTE: It may be desirable to place jiggle bars in Cross-Hatched Area to Discourage Crossing.
 *Longer distance desirable particularly for high volume Exit Ramp and/or Frontage Roads.

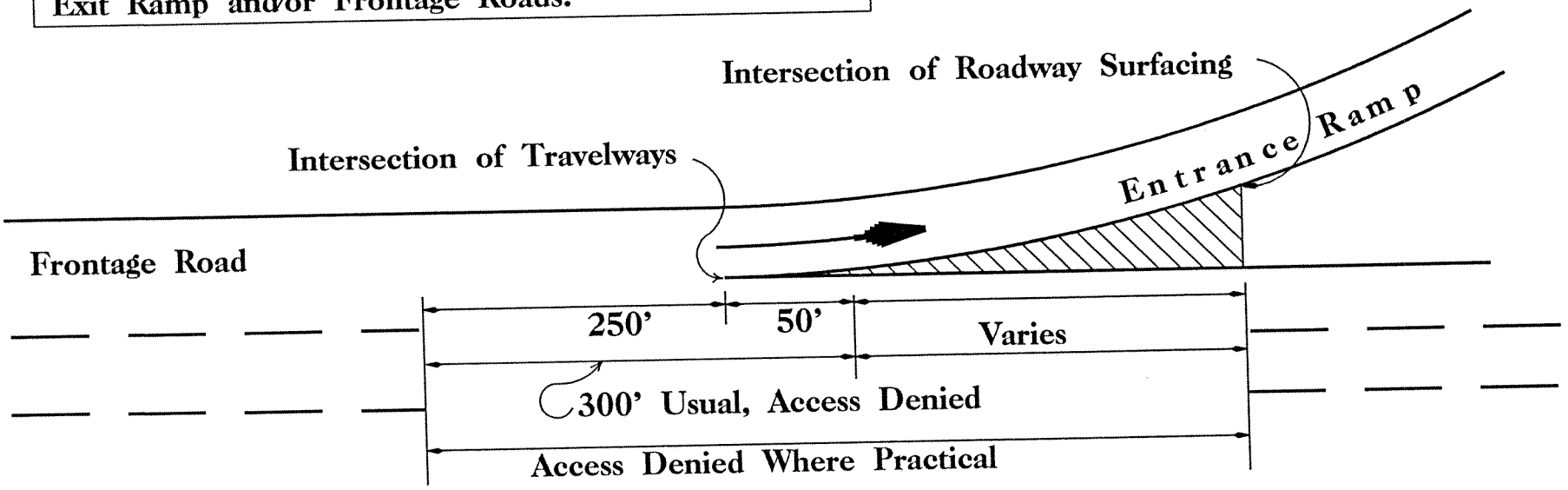

- Not to Scale -

Figure 3: Preferred Access Control at Entrance and Exit Ramp Junction with Freeway Frontage Road

Department of Development Services / Engineering Division



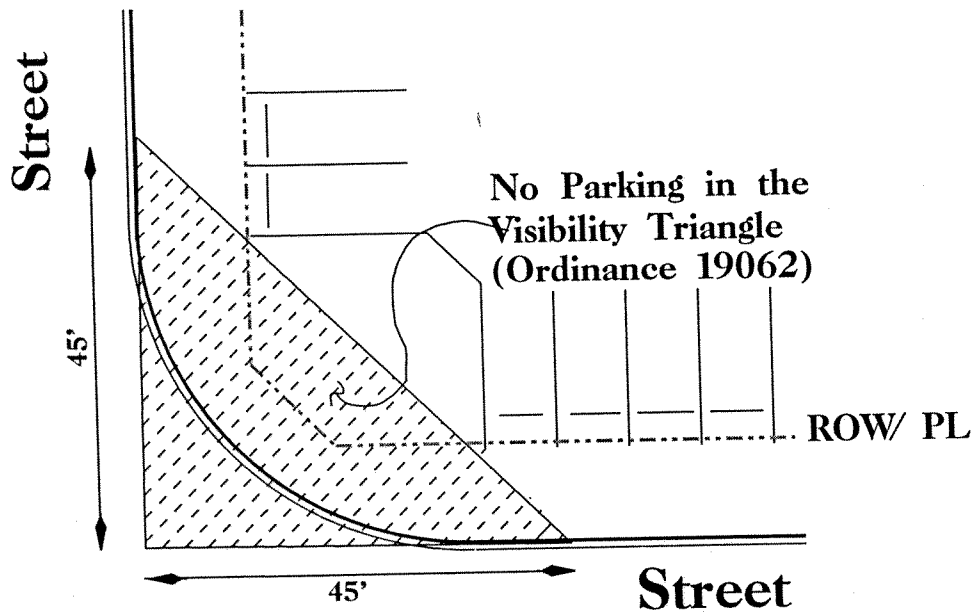

45' x 45' Visibility Triangle in all Zoning except:

- CBD - Central Business District
- PD 269 (Deep Ellum / Near Eastside District)
- PD 225 (State - Thomas Special Purpose District)
- PD 193 (Oak Lawn Special Purpose District: only for streets listed in the Thoroughfare Plan) where the visibility triangle is 30' x 30'

No Parking in the Visibility Triangle (Ordinance 19062)

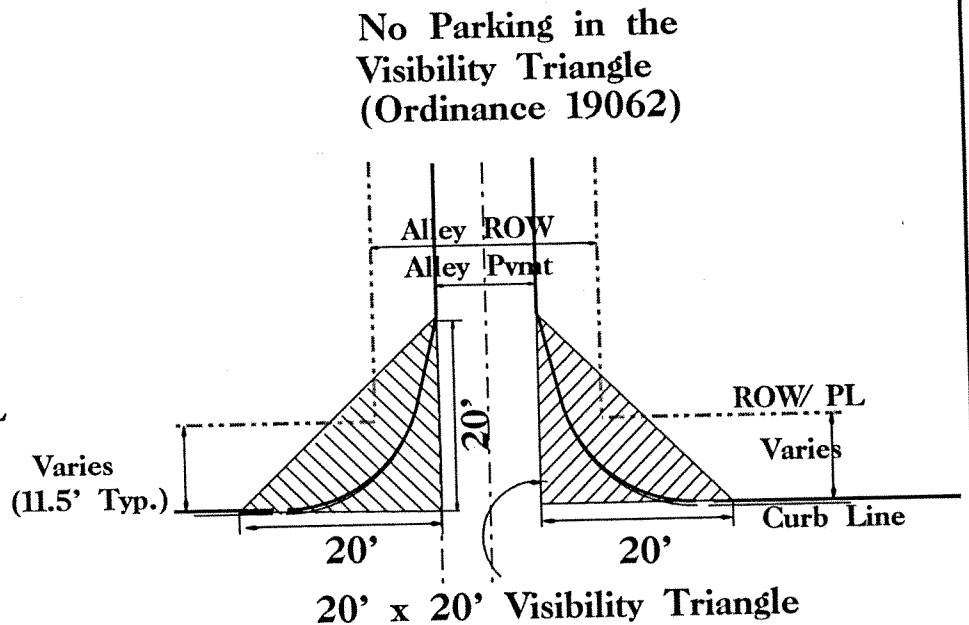
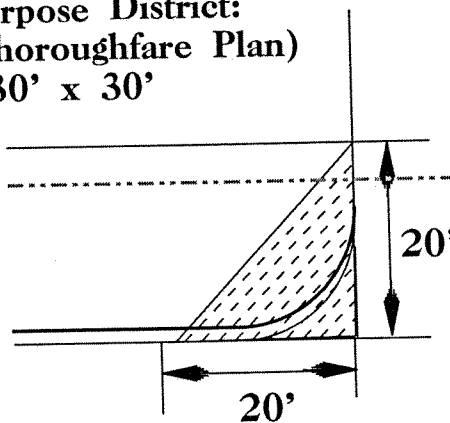

Driveway Entrance / Exit

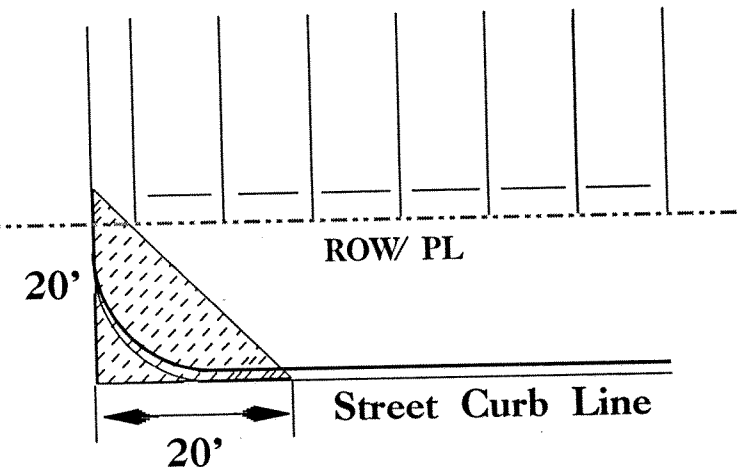

- Scale: 1" = 20' -

Figure 4: Visibility Triangle Guidelines

Department of Development Services / Engineering Division



Central Business District Defined

For the purpose of this division, the Central Business District shall be that area bounded by the following street lines:

- The South line of Young Street from Houston Street to Central Expressway.
 - The East line of Central Expressway from Young Street to Pacific
 - The north line of Pacific Avenue from Central to Pearl
 - The East line of Pearl Street from Pacific to Ross
 - The North line of Ross Avenue from Pearl to Houston.
 - The West line of Houston Street from Ross to Young
- (Ordinance 14584)

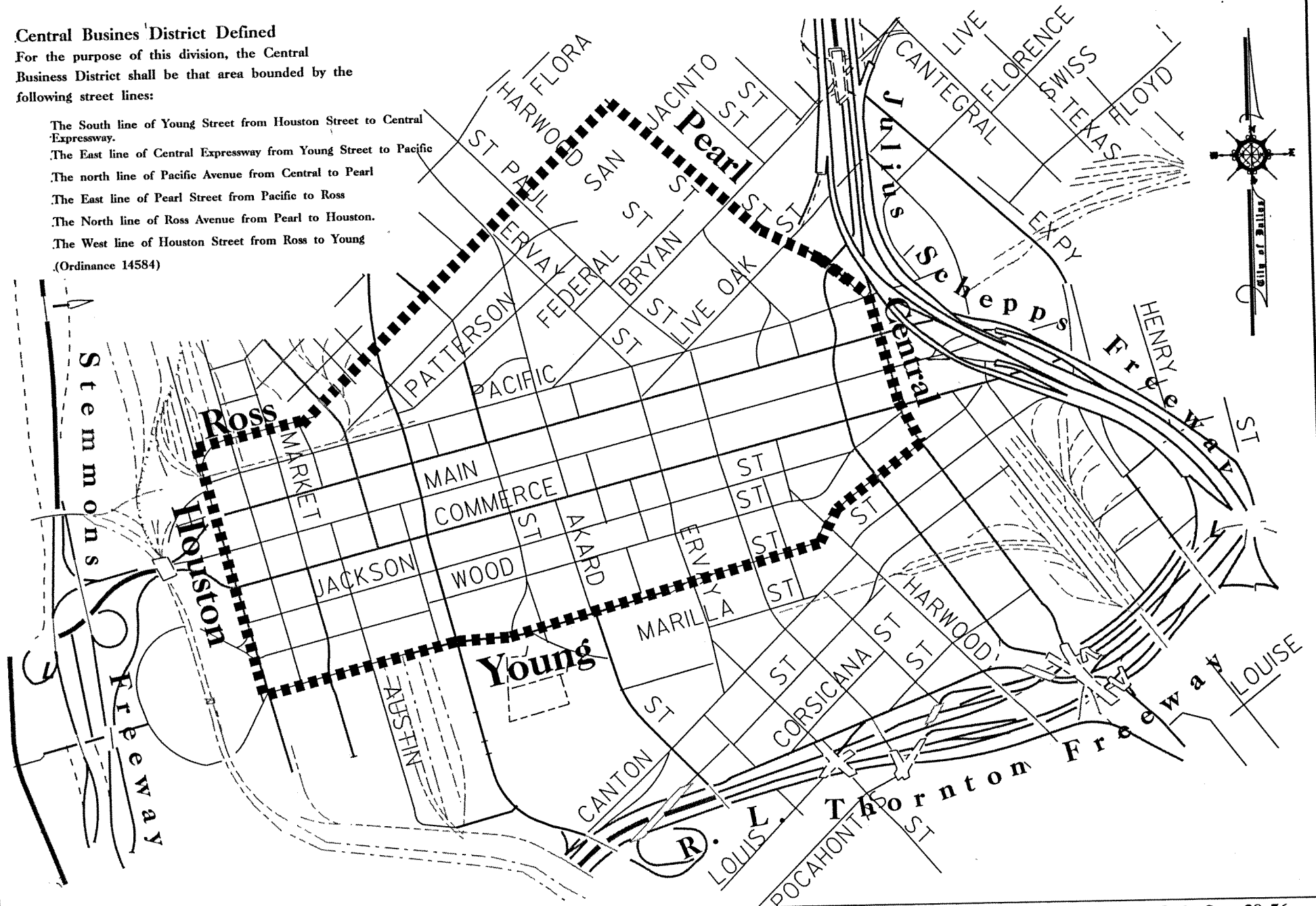

- Not To Scale -

Reference Dallas City Code Sec. 28-56

Figure 4a: Central Business District

Department of Development Services / Engineering Division



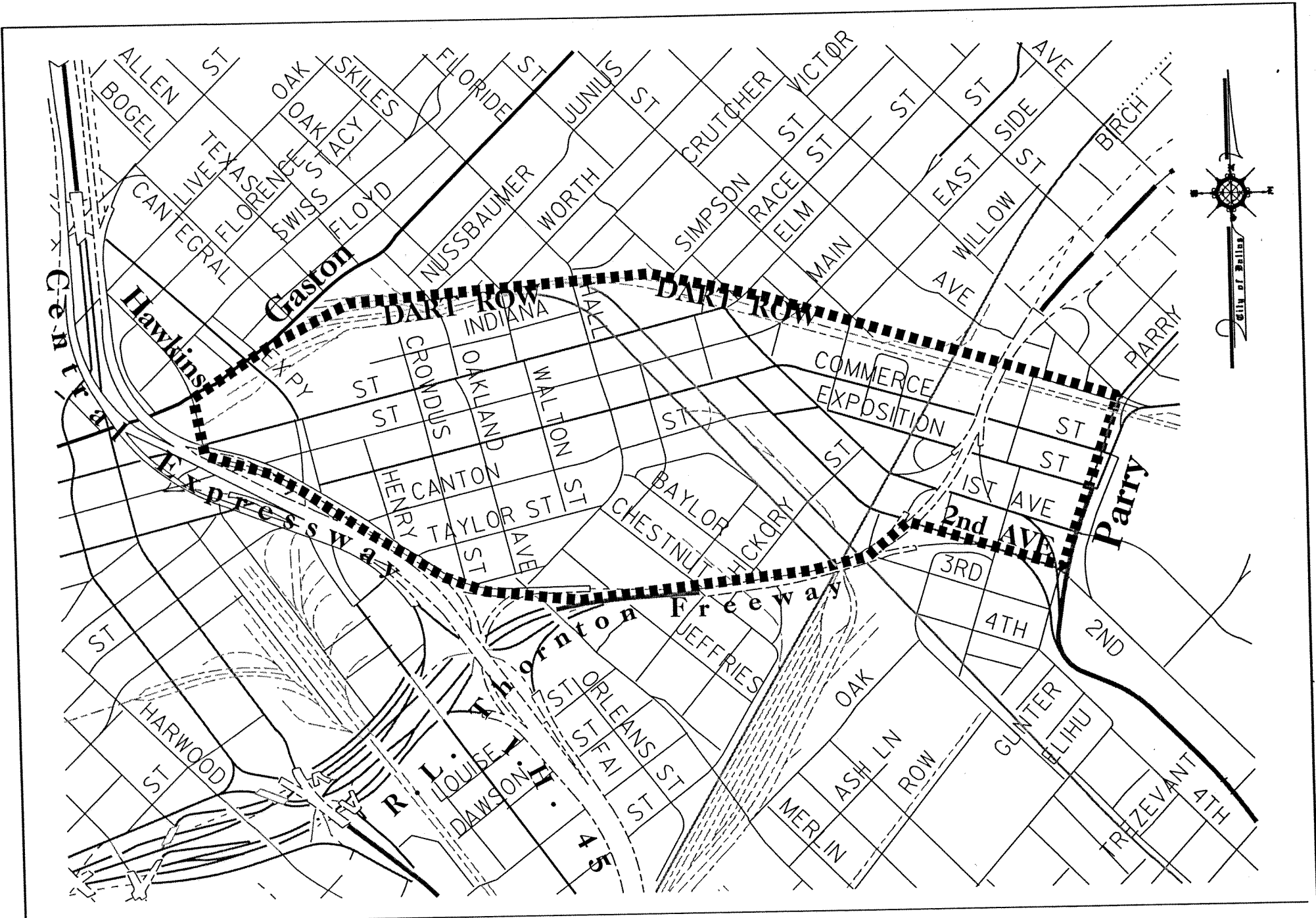

- Not To Scale -



Figure 4b: PD 269 (Deep Ellum / Near Eastside District)

Department of Development Services / Engineering Division



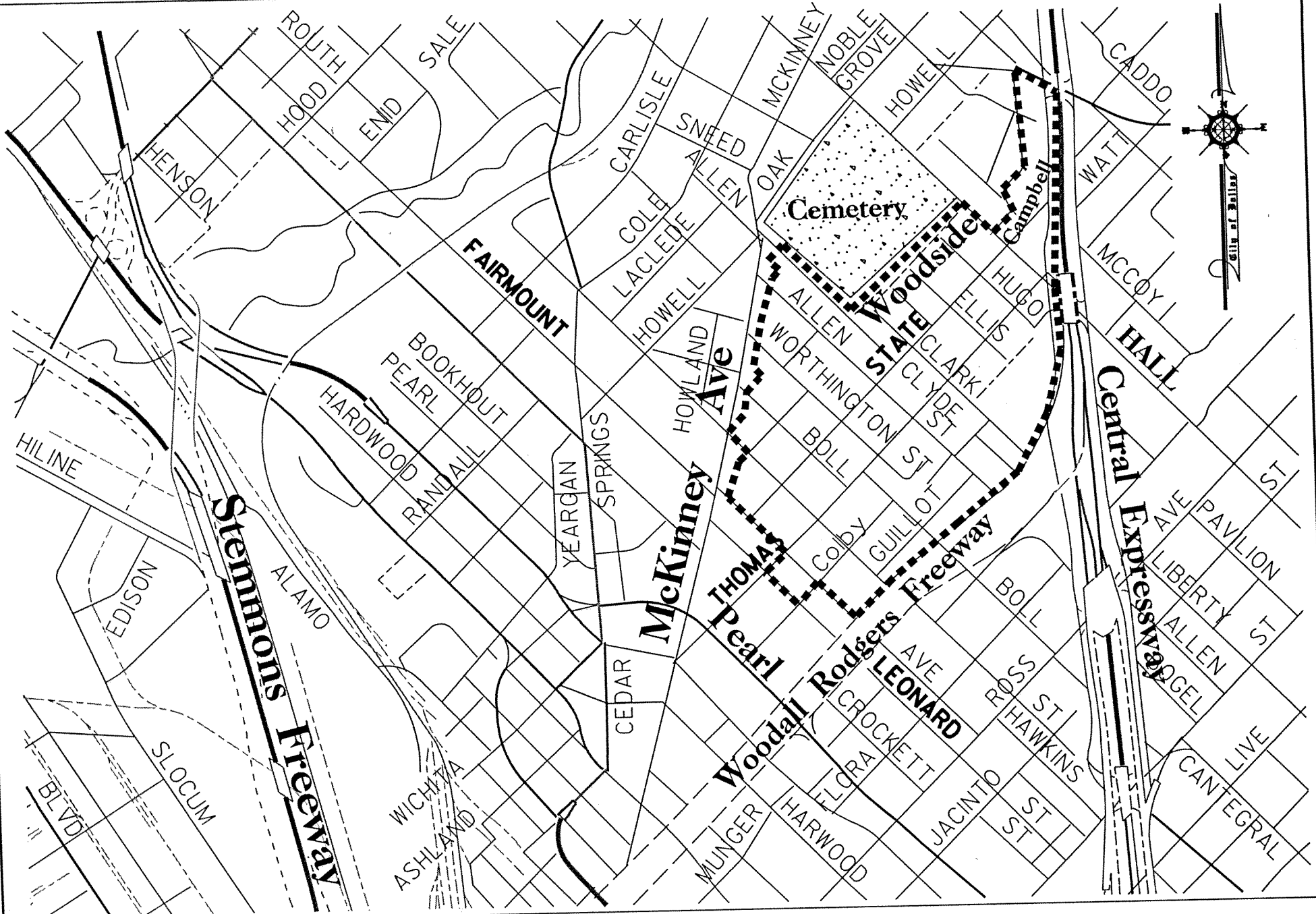

- Not To Scale -



Figure 4c: PD 225 (State-Thomas Special Purpose District)



Department of Development Services / Engineering Division

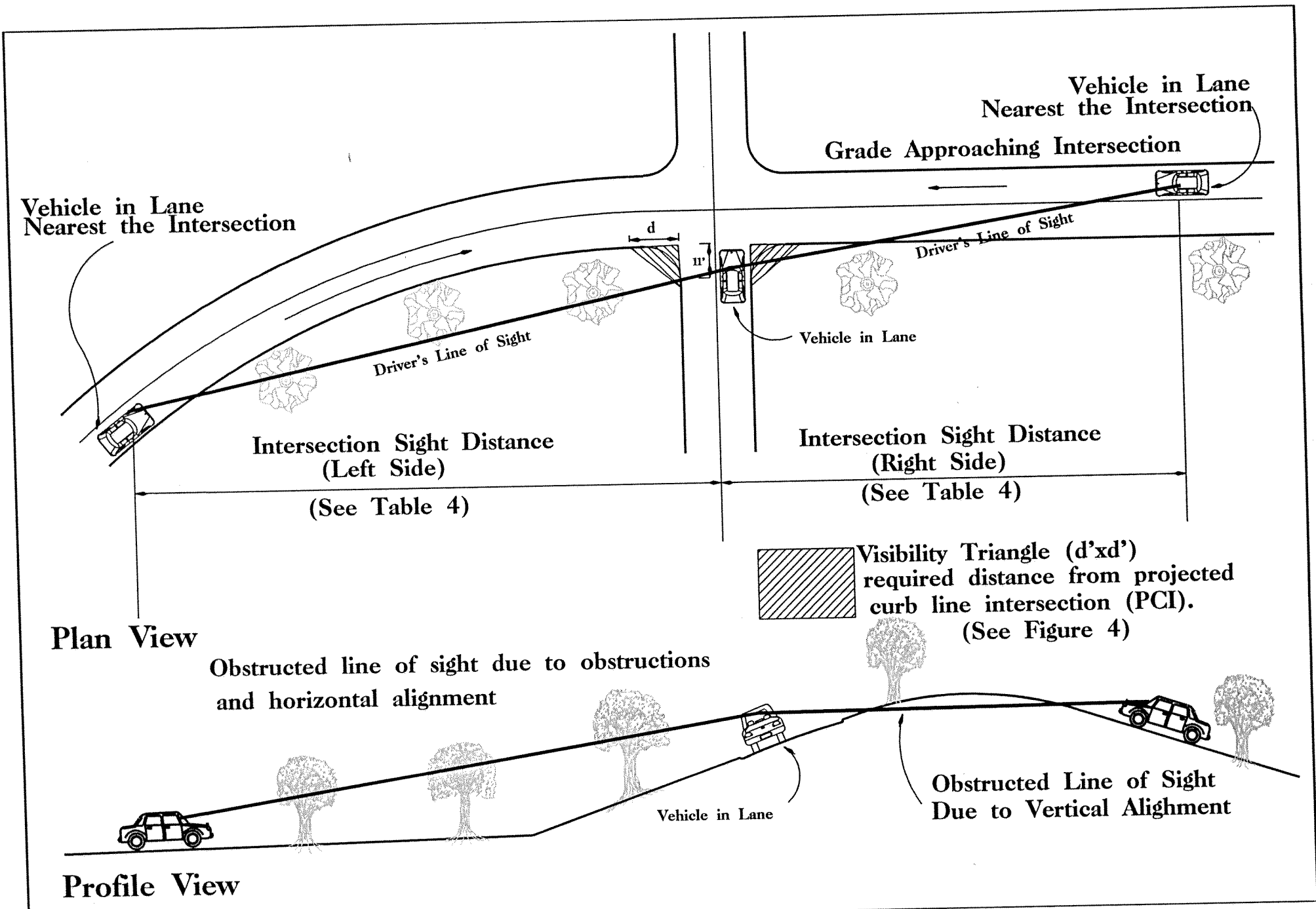
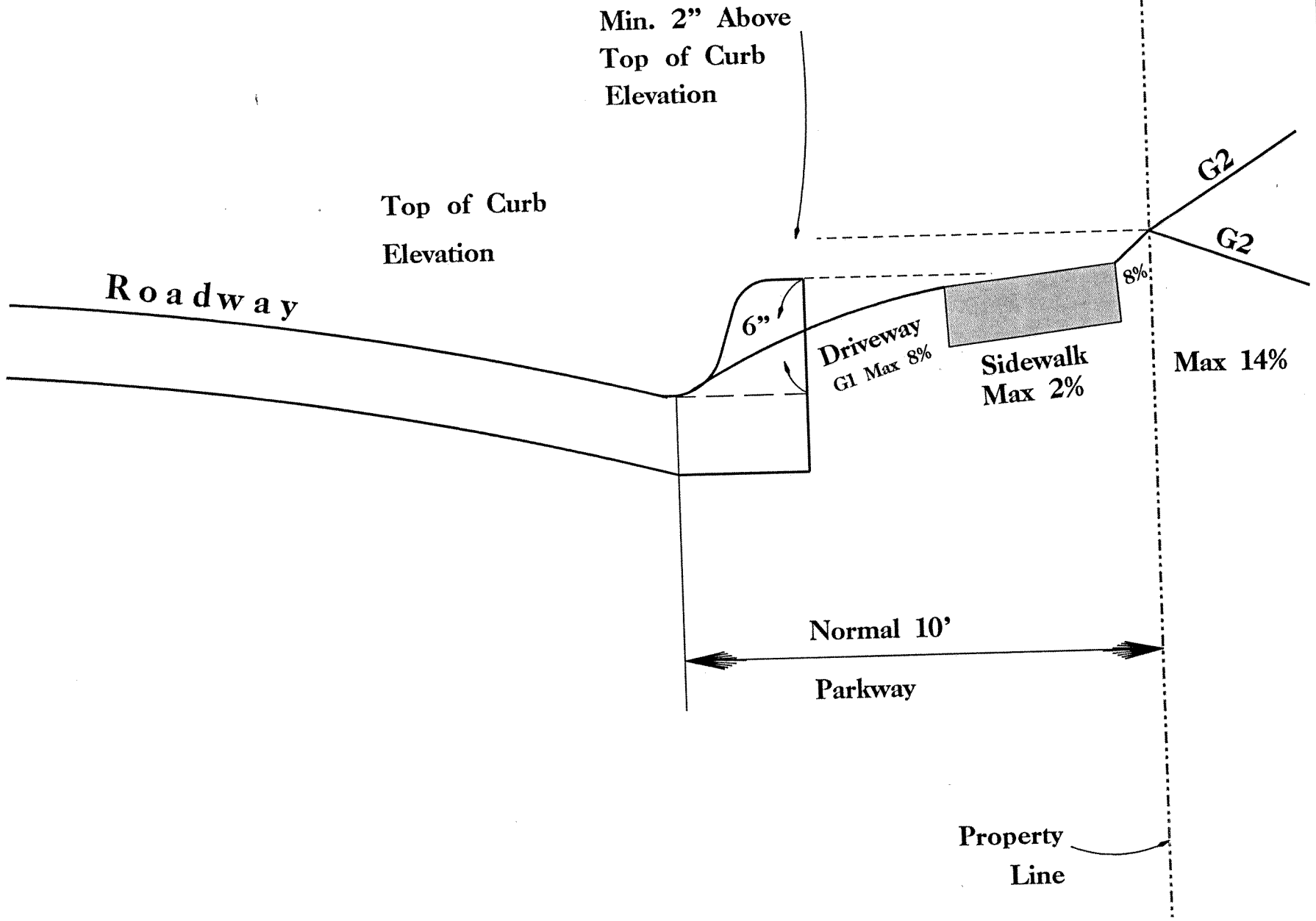

Figure 5: Sight Distance at Intersections

Department of Development Services / Engineering Division





- Not To Scale-

Figure 7: Driveway Profile

Department of Development Services / Engineering Division



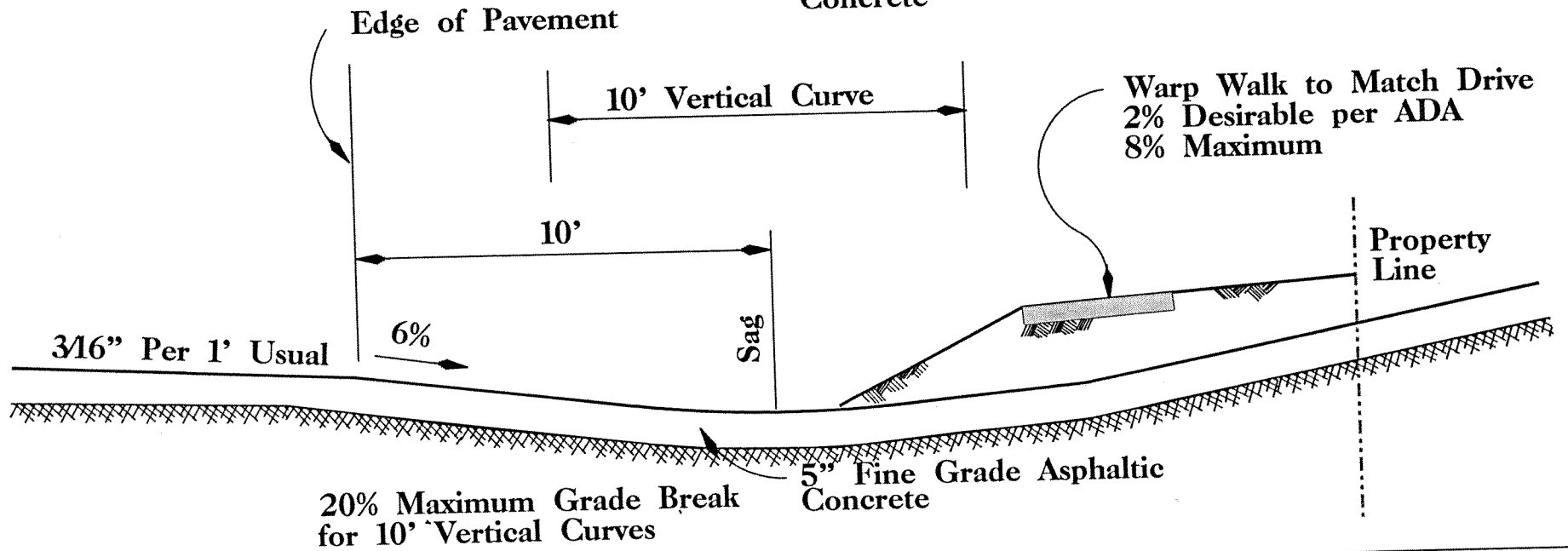
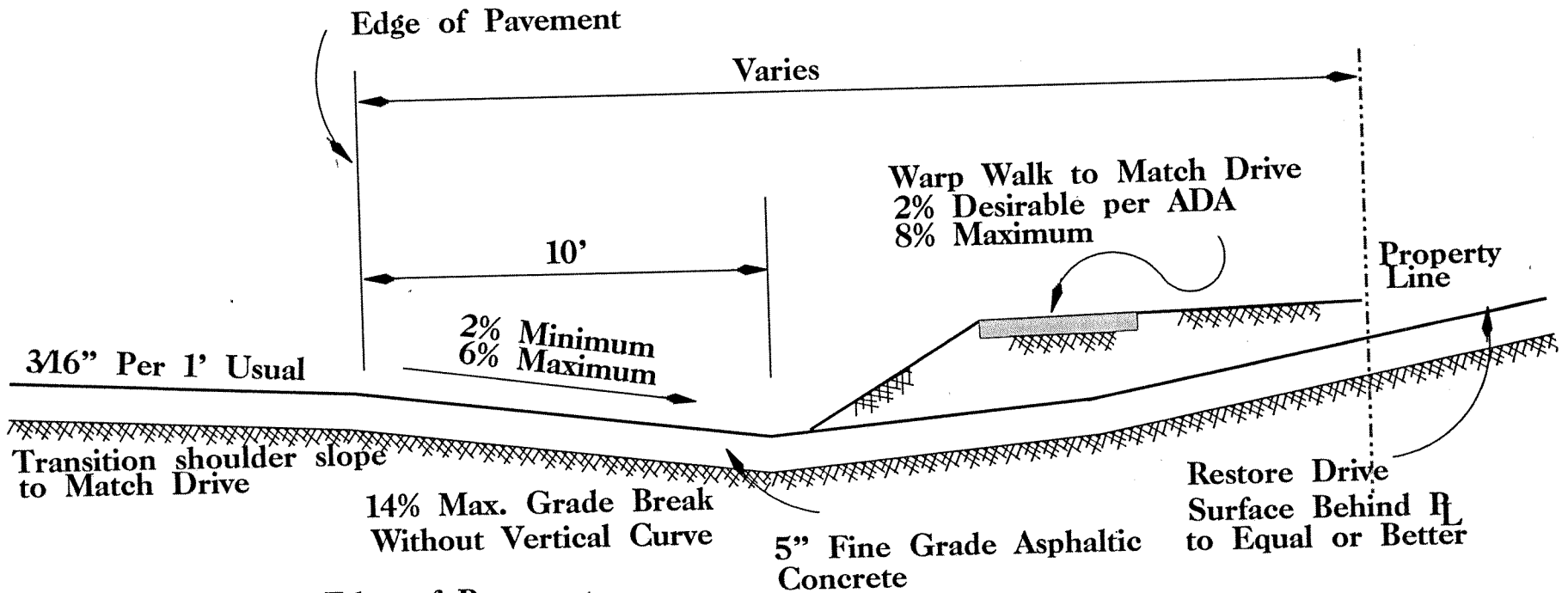

- Not To Scale -

Figure 8: Drives Without Culverts

Department of Development Services / Engineering Division



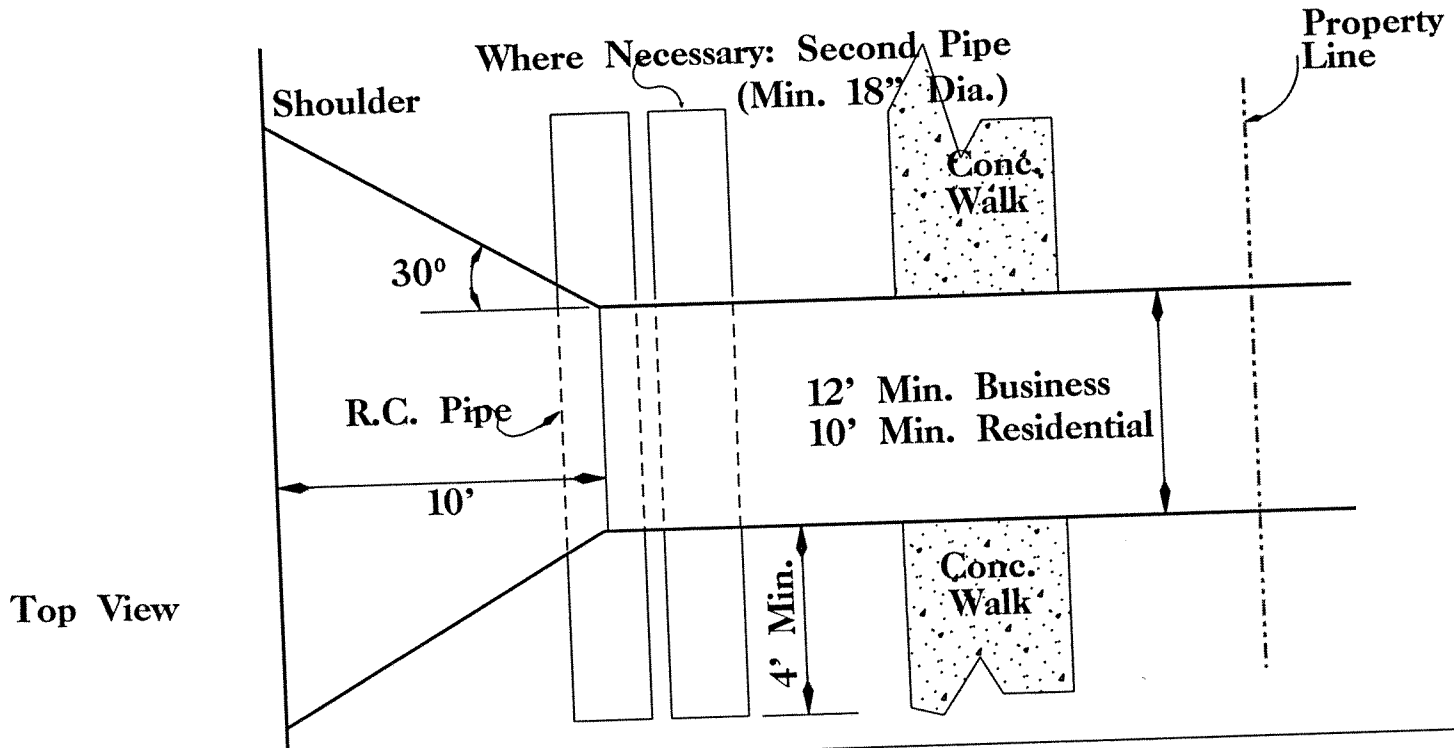
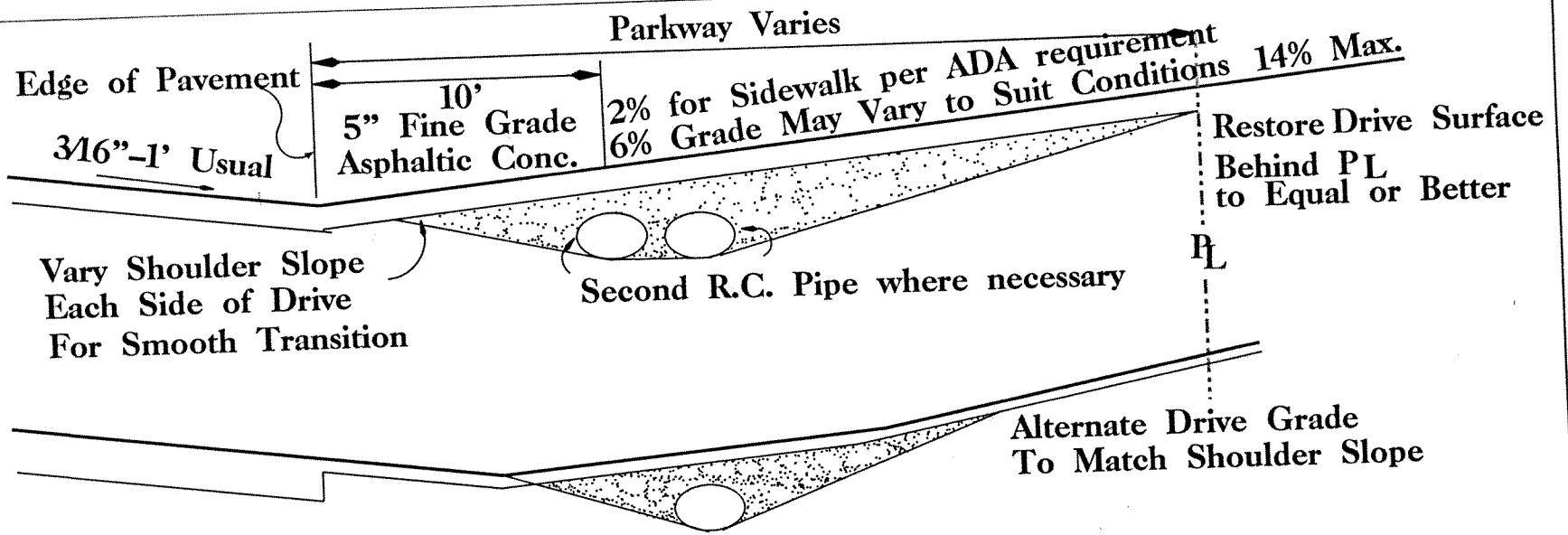

- Not To Scale -

Figure 9: Drives with Culverts

Department of Development Services / Engineering Division



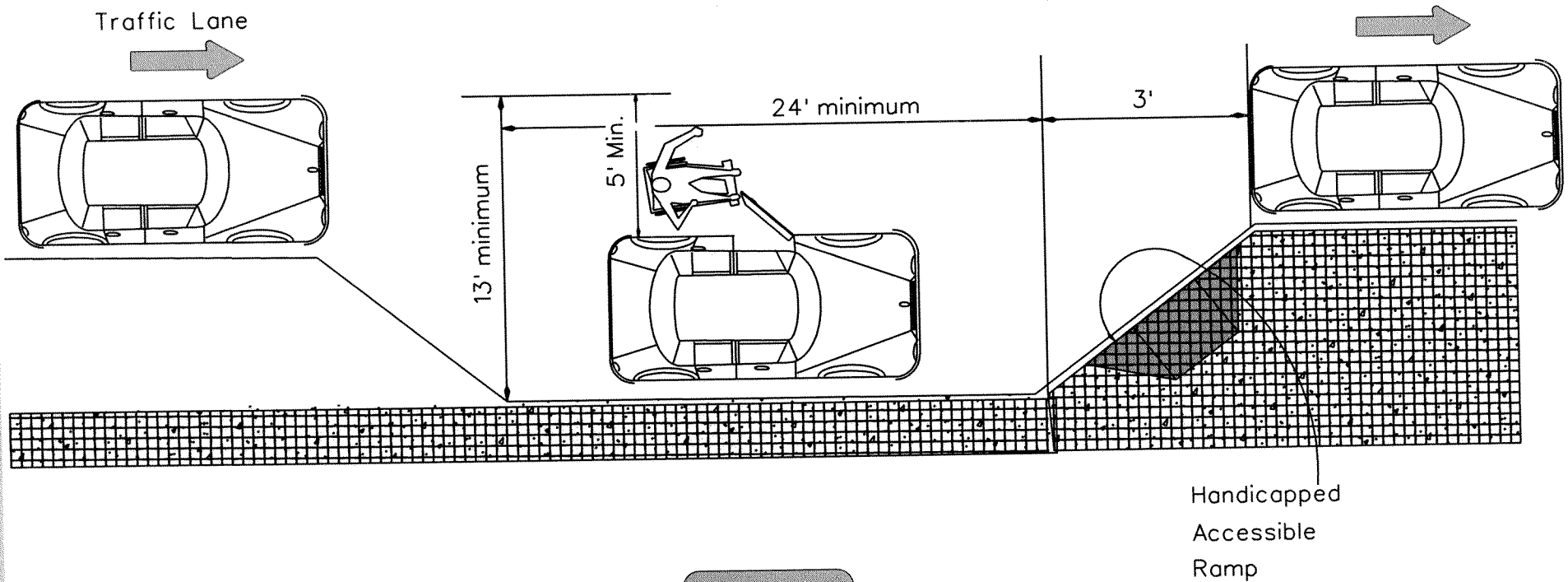

Notes:

1. All Dimensions and Signage must adhere to the Texas Assessibility Standards (TAS)

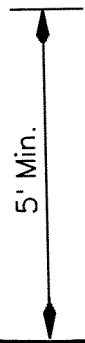

- NOT TO SCALE -

Ref.: PWT Paving Design Manual, June 1998, Page IV-106

Figure 10: Handicapped Passenger Loading Zone & Signage

Department of Development Services / Engineering Division

Rev. 1, Aug 13, 2004

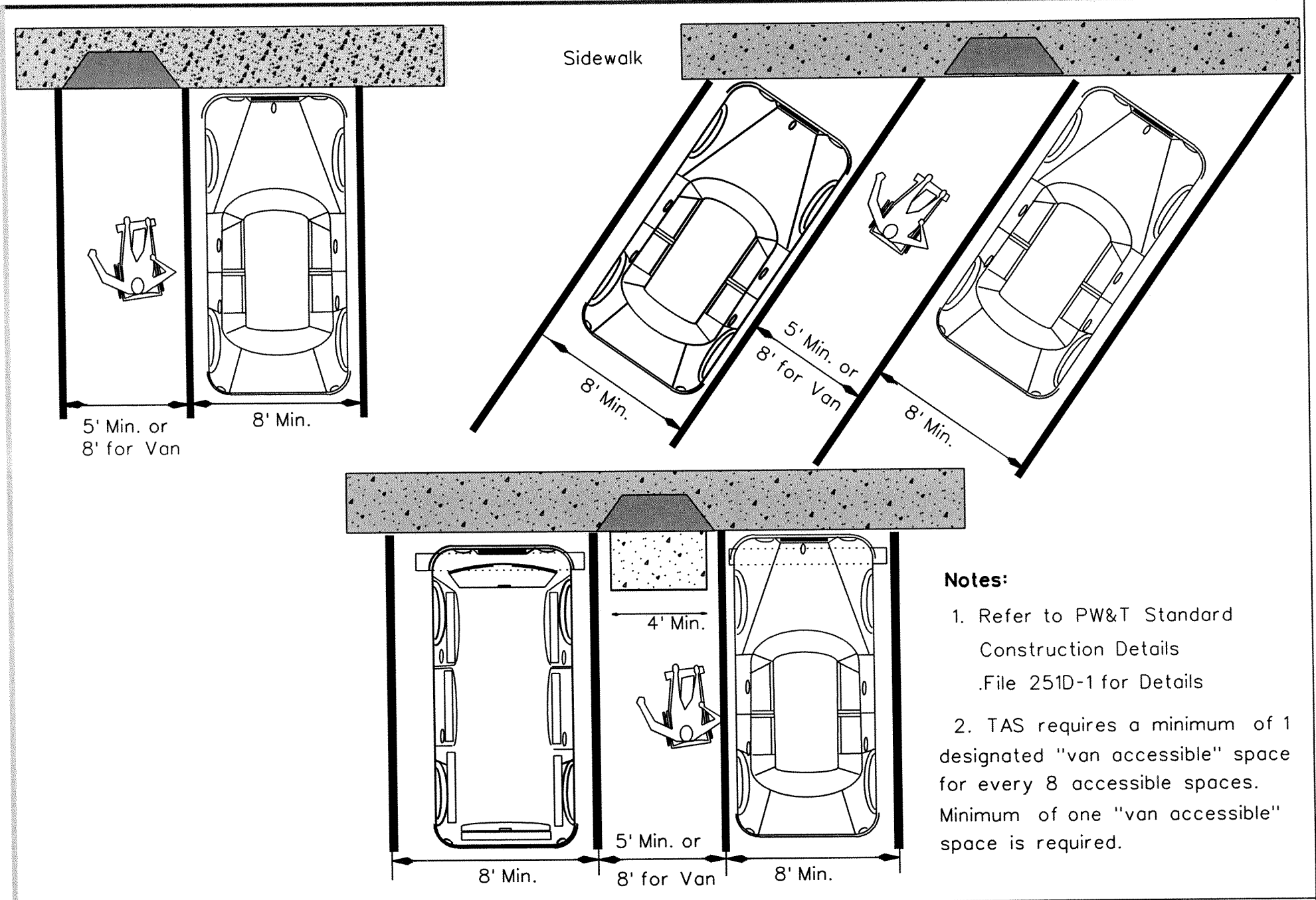

- Not To Scale -

Rev. 1, Aug 13, 2004

Figure 11: Handicapped Parking
 Department of Development Services / Engineering Division

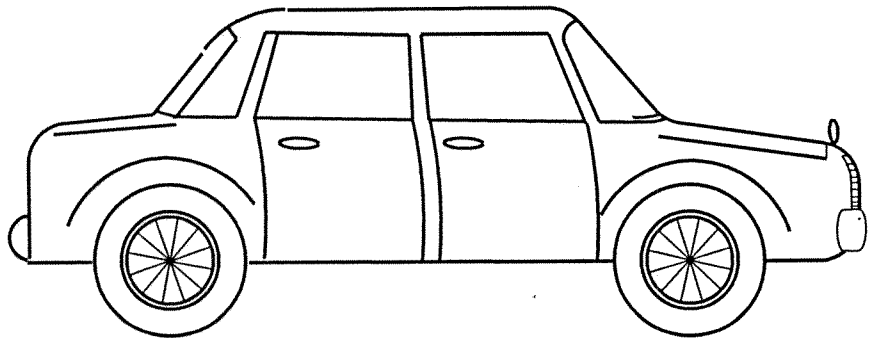

17' - 10"

Standard Size

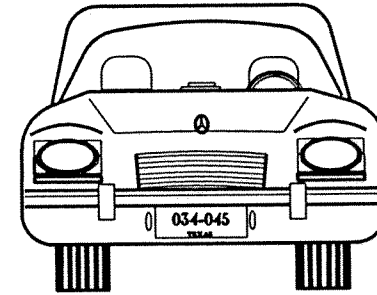

6' - 5"

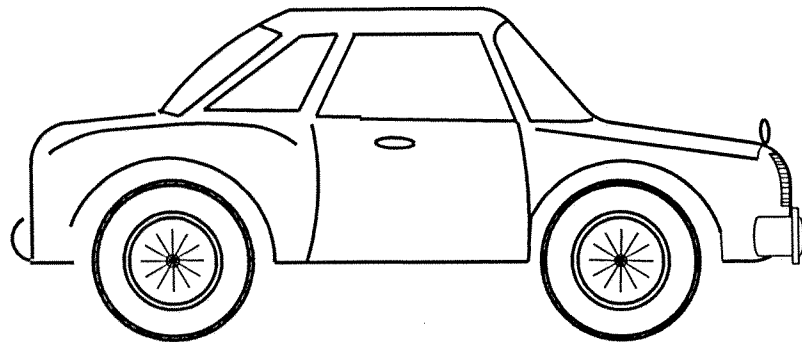

16' - 0"

Compact Size

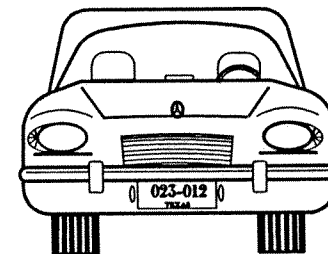

5' - 8"

- Scale: 1" = 40' -

Figure 12: Design Vehicle for Parking Stall Design

Department of Development Services / Engineering Division



For Dimensions, See Table 11

A = Parking Angle

B = Stall Width

D = Aisle Width

Y1 = Module width, one row

Y2 = Module width, two rows

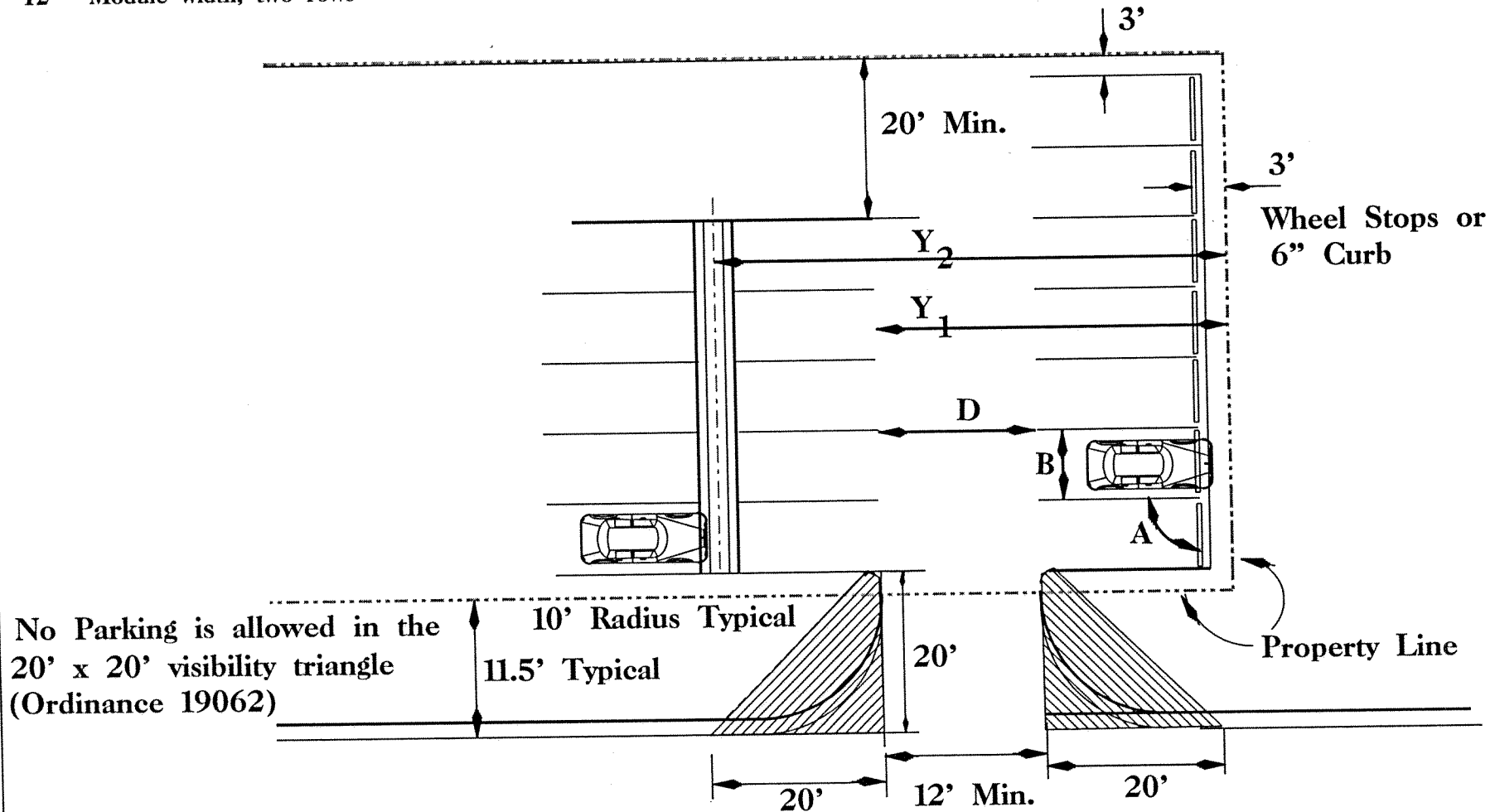

- Not To Scale -

Figure 13: Right Angle (90°) Parking

Department of Development Services / Engineering Division



For Dimensions, See Table II

A = Parking Angle

B = Stall Width

D = Aisle Width

Y1 = Module width, one row

Y2 = Module width, two rows

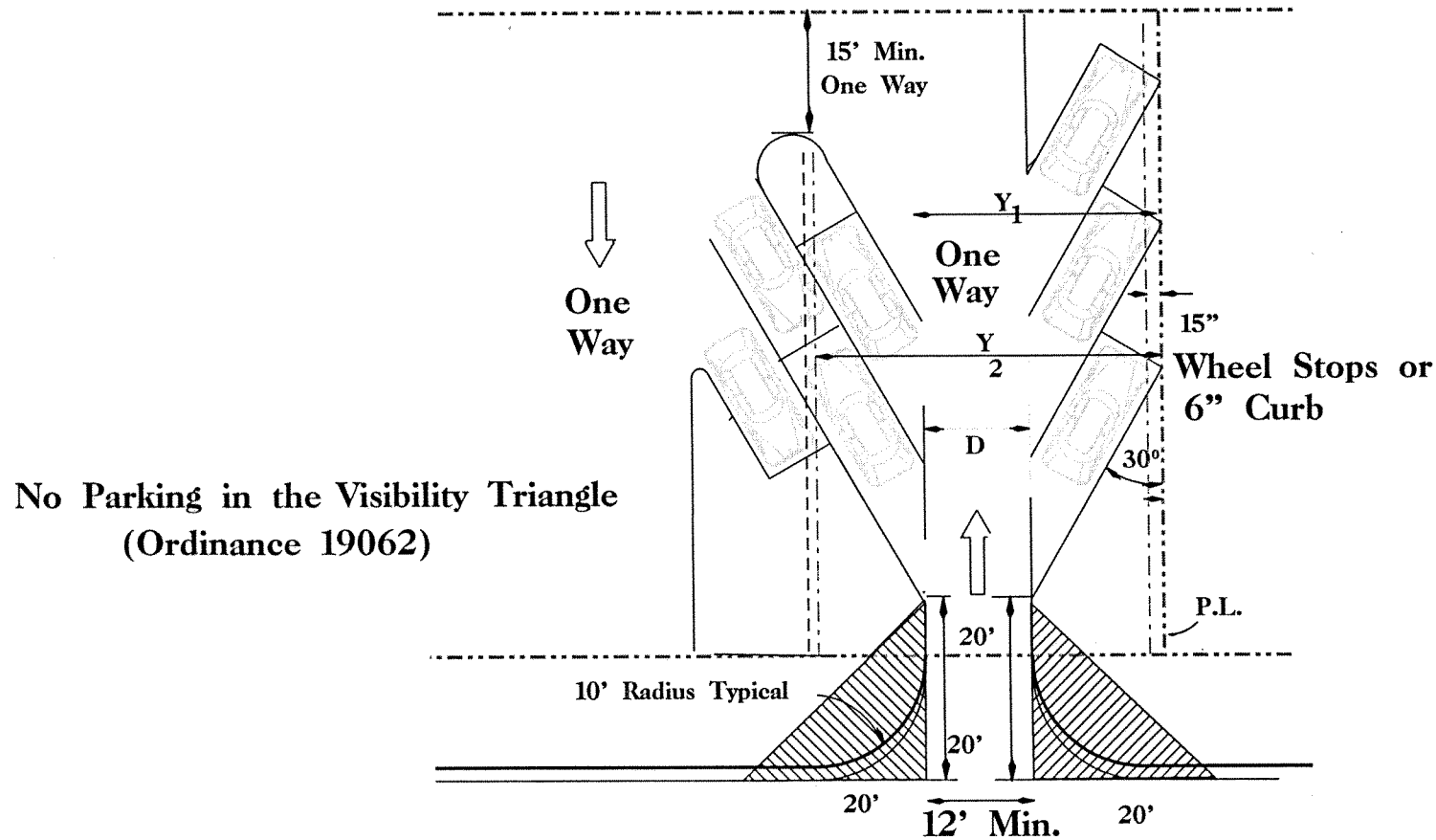

- Scale: 1" = 20' -

Figure 14: 30° Angle Parking

Department of Development Services / Engineering Division



For Dimensions, See Table 11

A = Parking Angle

B = Stall Width

D = Aisle Width

Y1 = Module width, one row

Y2 = Module width, two rows

No Parking is allowed in
Visibility Obstruction Triangle
(Ordinance 19062)

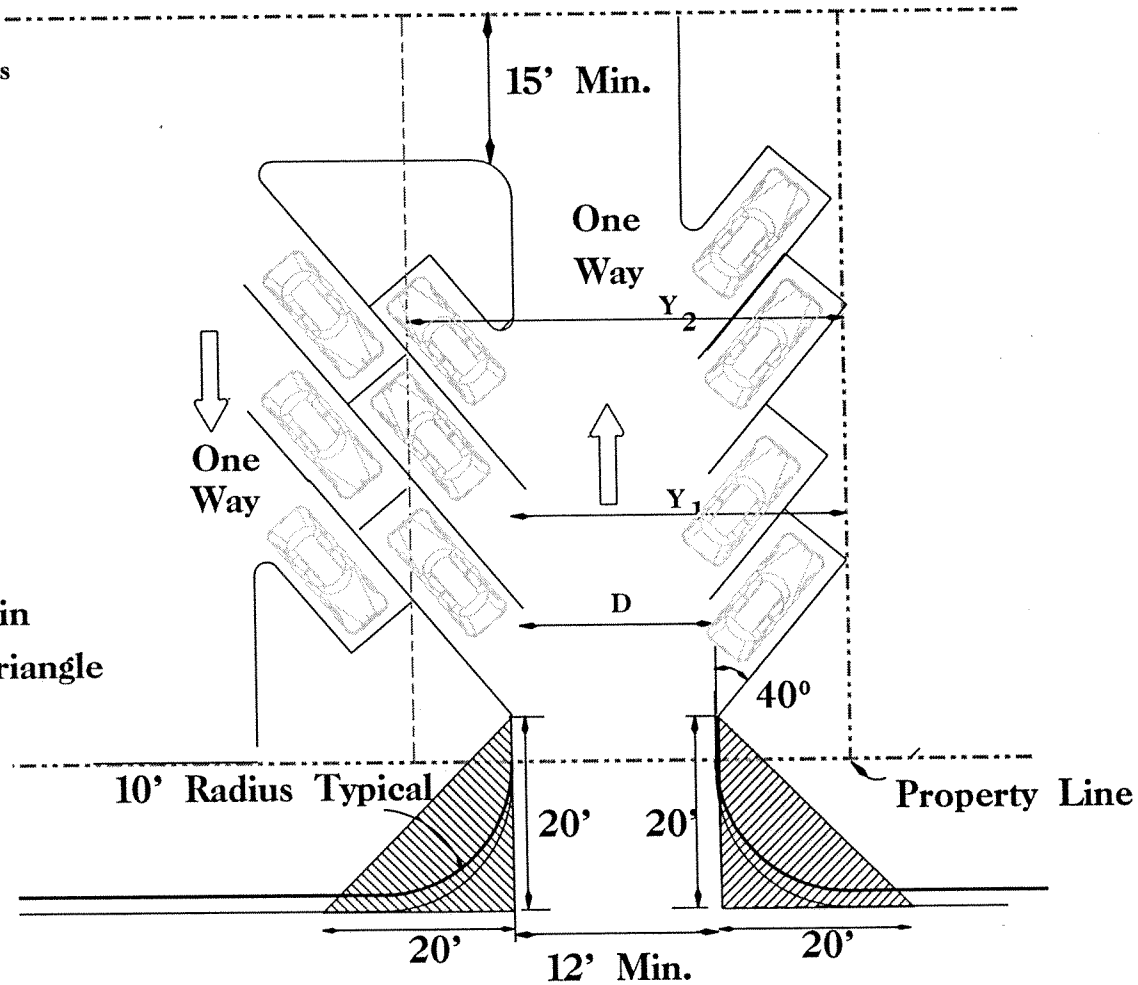

- Not To Scale -

Figure 15: 40° Angle Parking

Department of Development Services / Engineering Division



For Dimensions, See Table II

A = Parking Angle

B = Stall Width

D = Aisle Width

Y1 = Module width, one row

Y2 = Module width, two rows

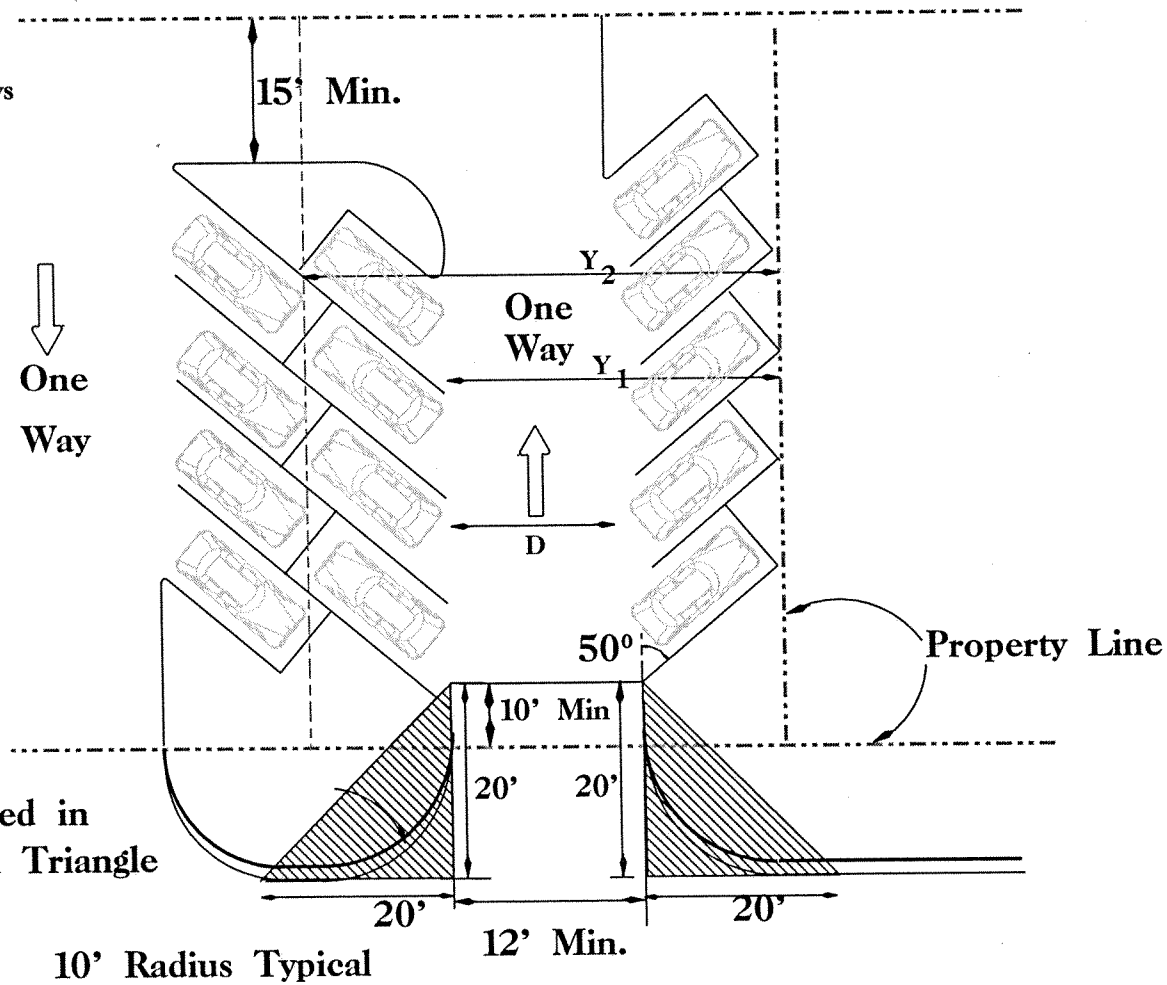

No Parking is allowed in
Visibility Obstruction Triangle
(Ordinance 19062)

10' Radius Typical

12' Min.

- Not To Scale -

Figure 16: 50° Angle Parking

Department of Development Services / Engineering Division



For Dimensions, See Table 11

A = Parking Angle

B = Stall Width

D = Aisle Width

Y1 = Module width, one row

Y2 = Module width, two rows

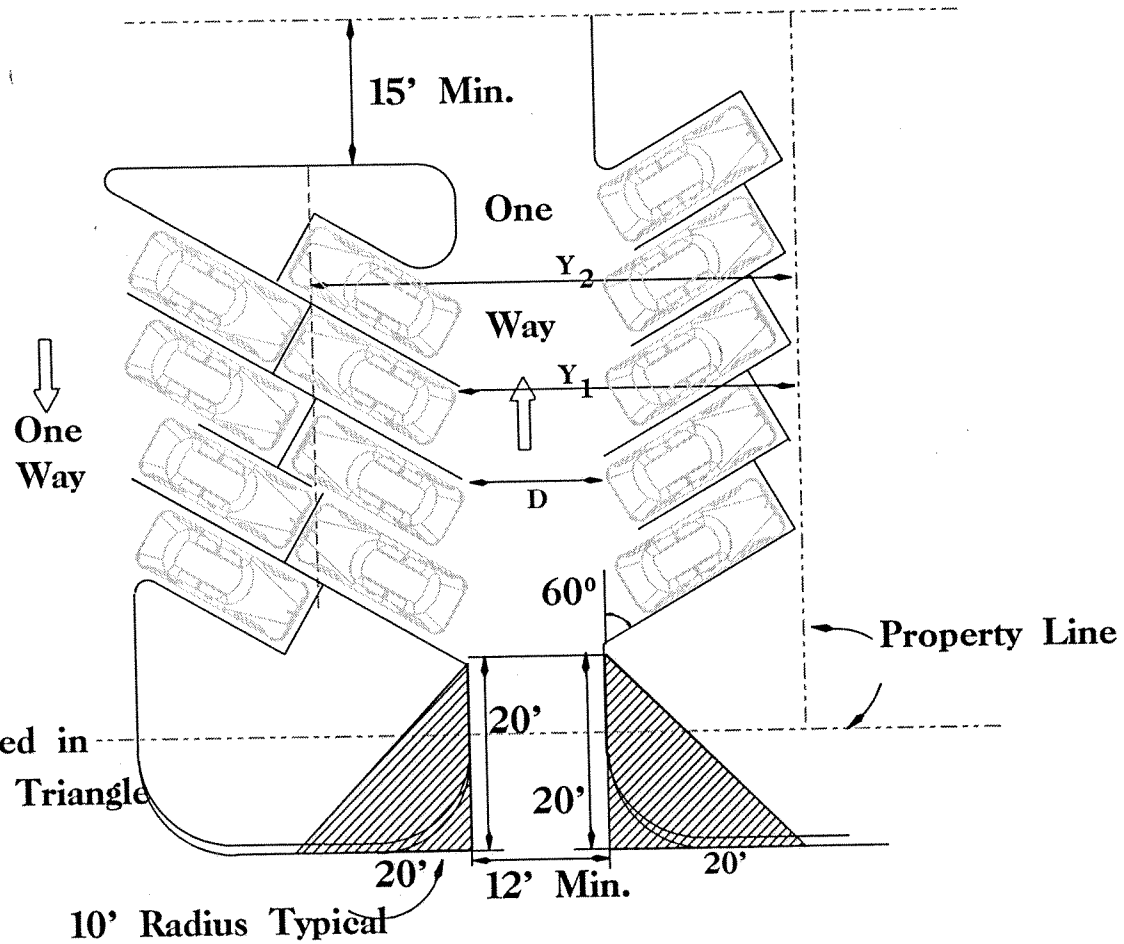

- Not To Scale -

Figure 17: 60° Angle Parking

Department of Development Services / Engineering Division



For Dimensions, See Table 11

A = Parking Angle

B = Stall Width

D = Aisle Width

Y1 = Module width, one row

Y2 = Module width, two rows

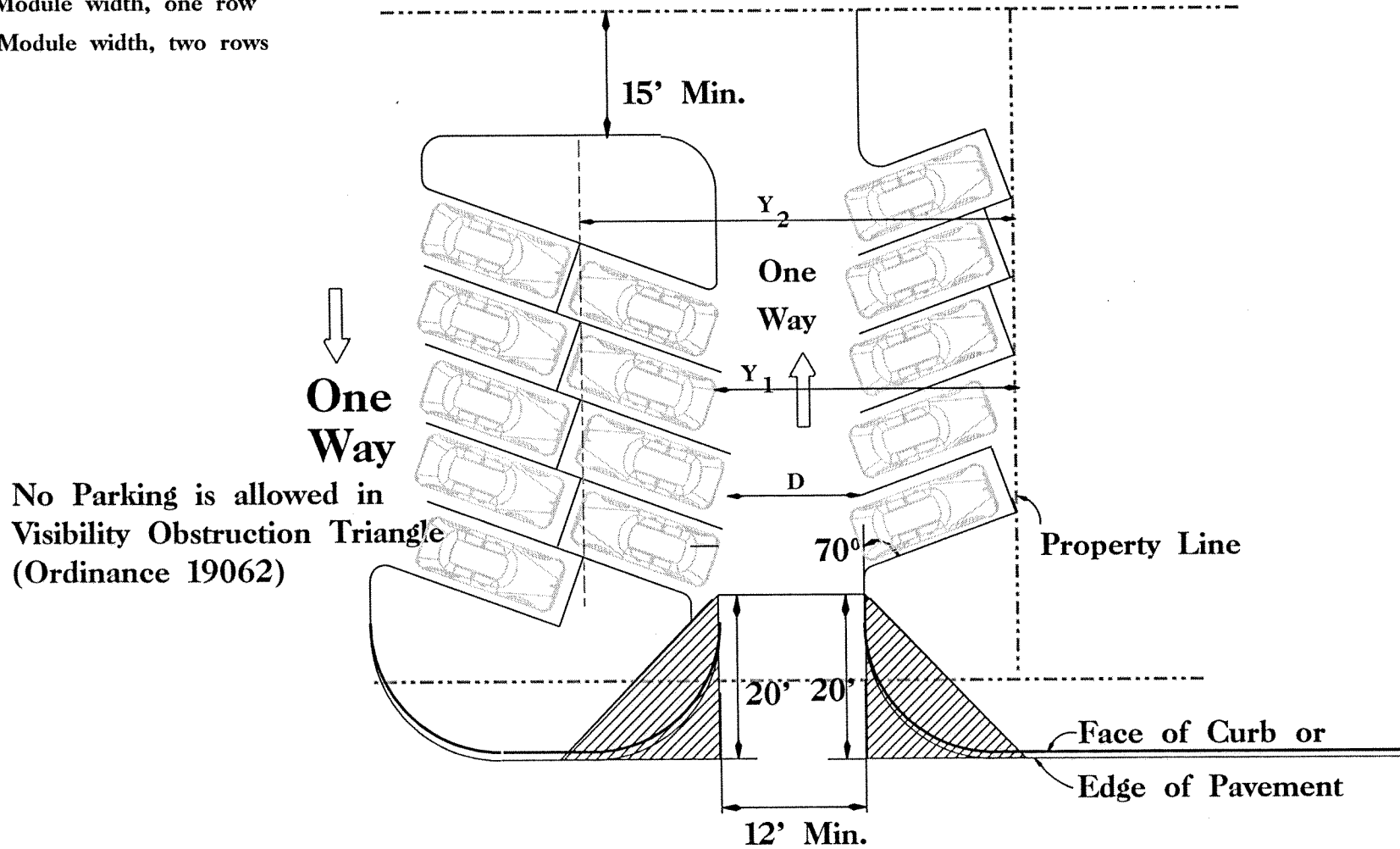

- Not To Scale -

Figure 18: 70° Angle Parking

Department of Development Services / Engineering Division



For Dimensions, See Table II

A = Parking Angle

B = Stall Width

D = Aisle Width

Y1 = Module width, one row

Y2 = Module width, two rows

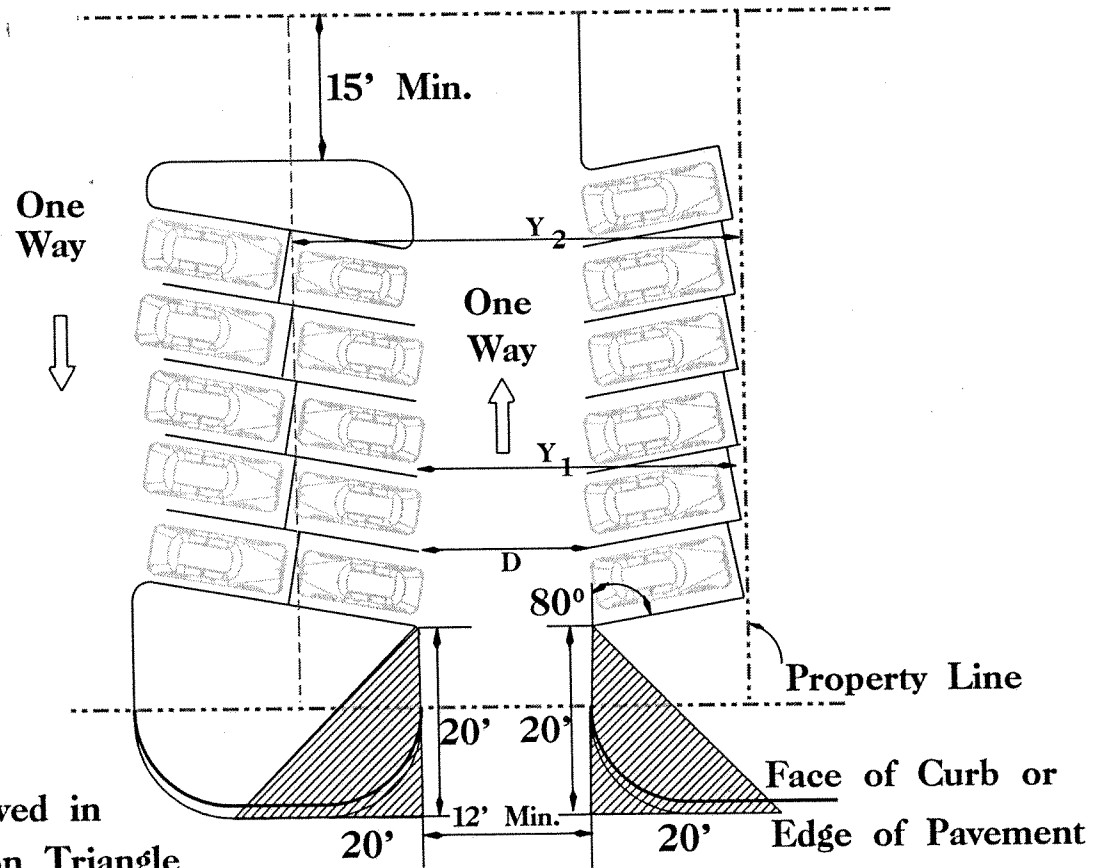

No Parking is allowed in
Visibility Obstruction Triangle
(Ordinance 19062)

- Not To Scale -

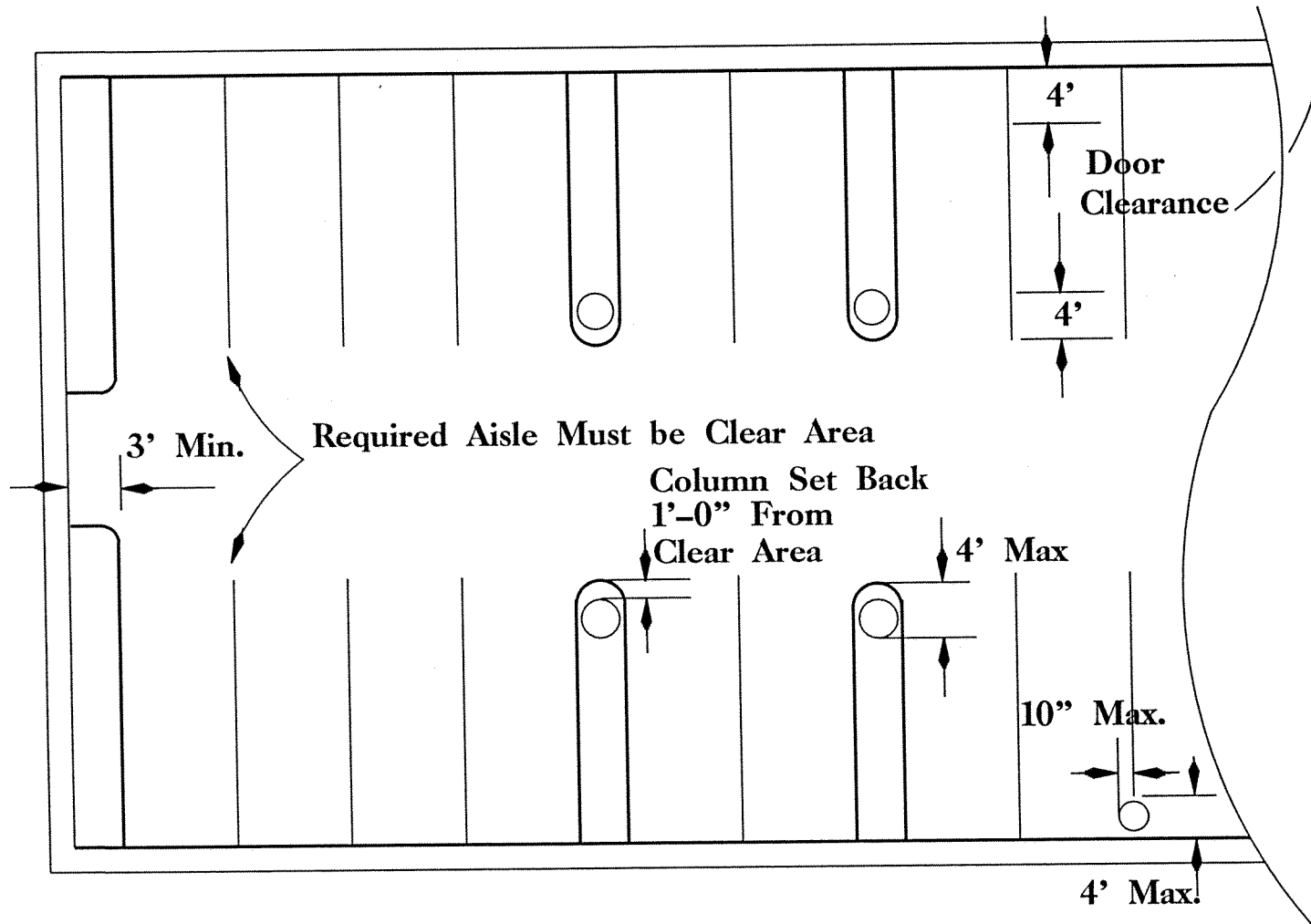

Figure 19: 80° Angle Parking

Department of Development Services / Engineering Division



Columns, Walls or Fixed Objects
Within This Area Assigned For
Door Clearance Will Require An
Additional width of 1.5' for Opening of door



- Not To Scale -

Figure 20: Structured Parking Garage

Department of Development Services / Engineering Division



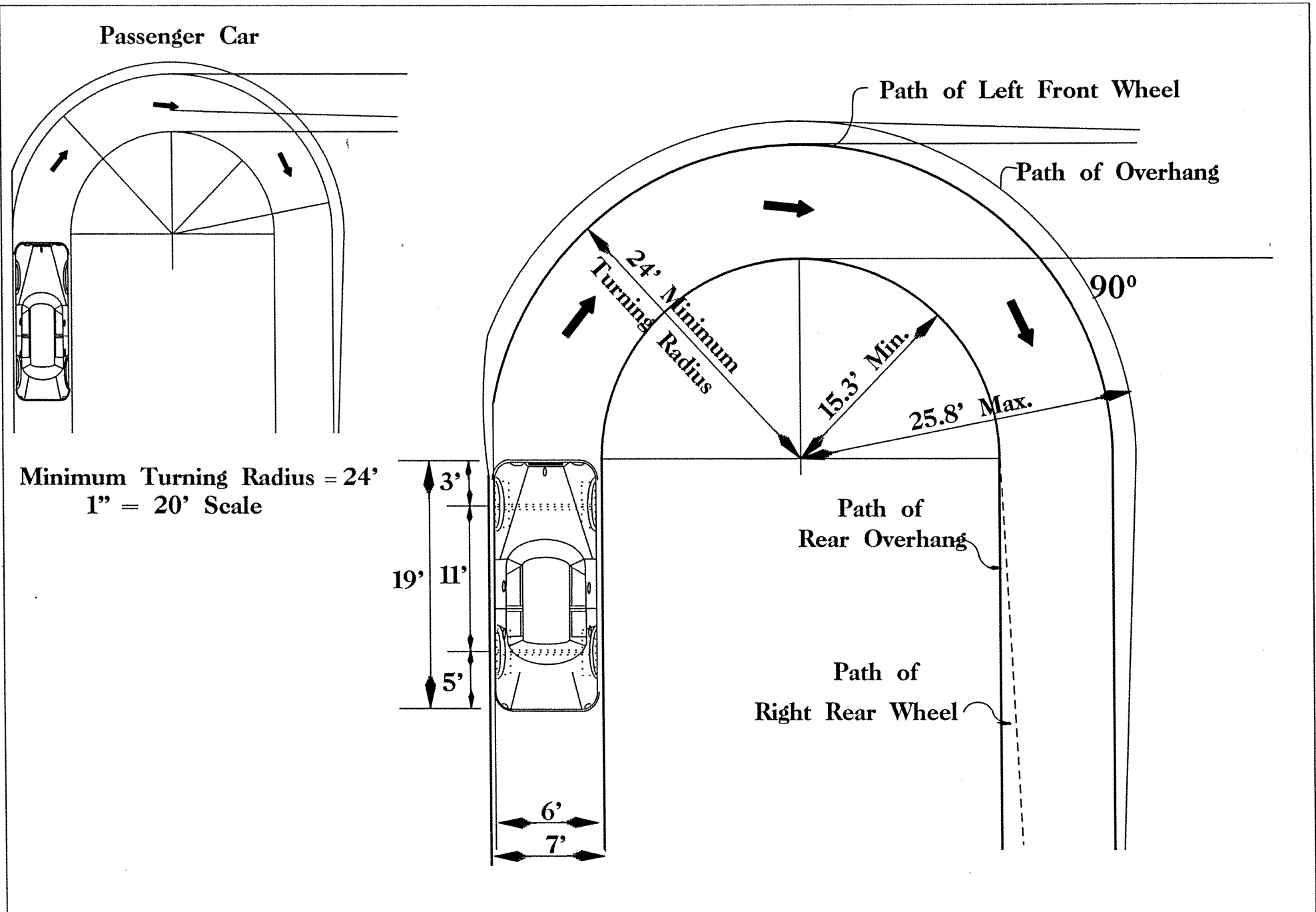

- Scale: 1" = 10' -

For Reference Purposes Only, For Design Use AASHTO Template (1994)

Figure 21: "P" Design Vehicle Turning Radius

Department of Development Services / Engineering Division



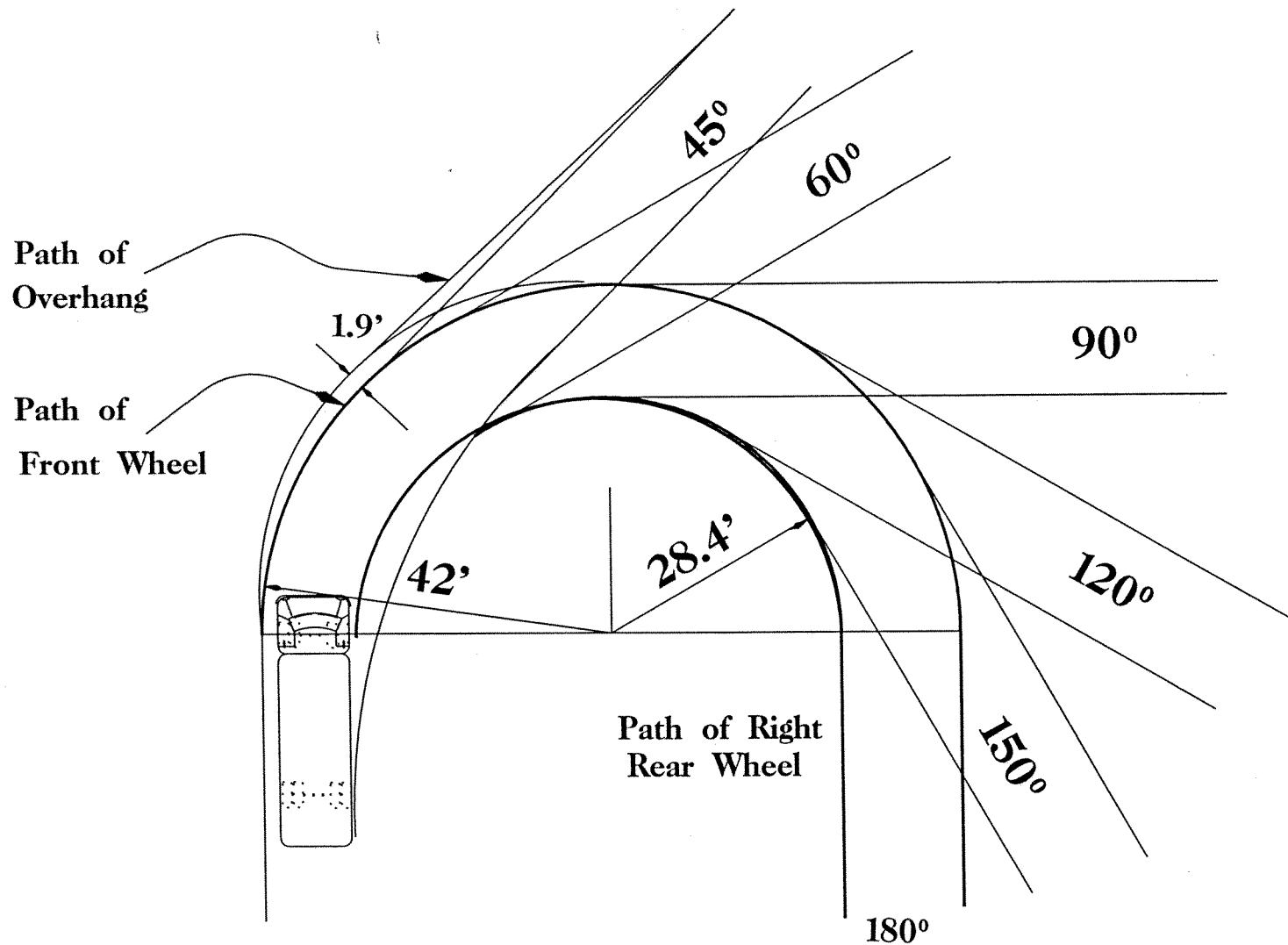

- Scale: 1" = 20' -

For Reference Purposes Only, For Design Use AASHTO Template (1994)

Figure 22: "SU" Design Vehicle
 Department of Development Services / Engineering Division



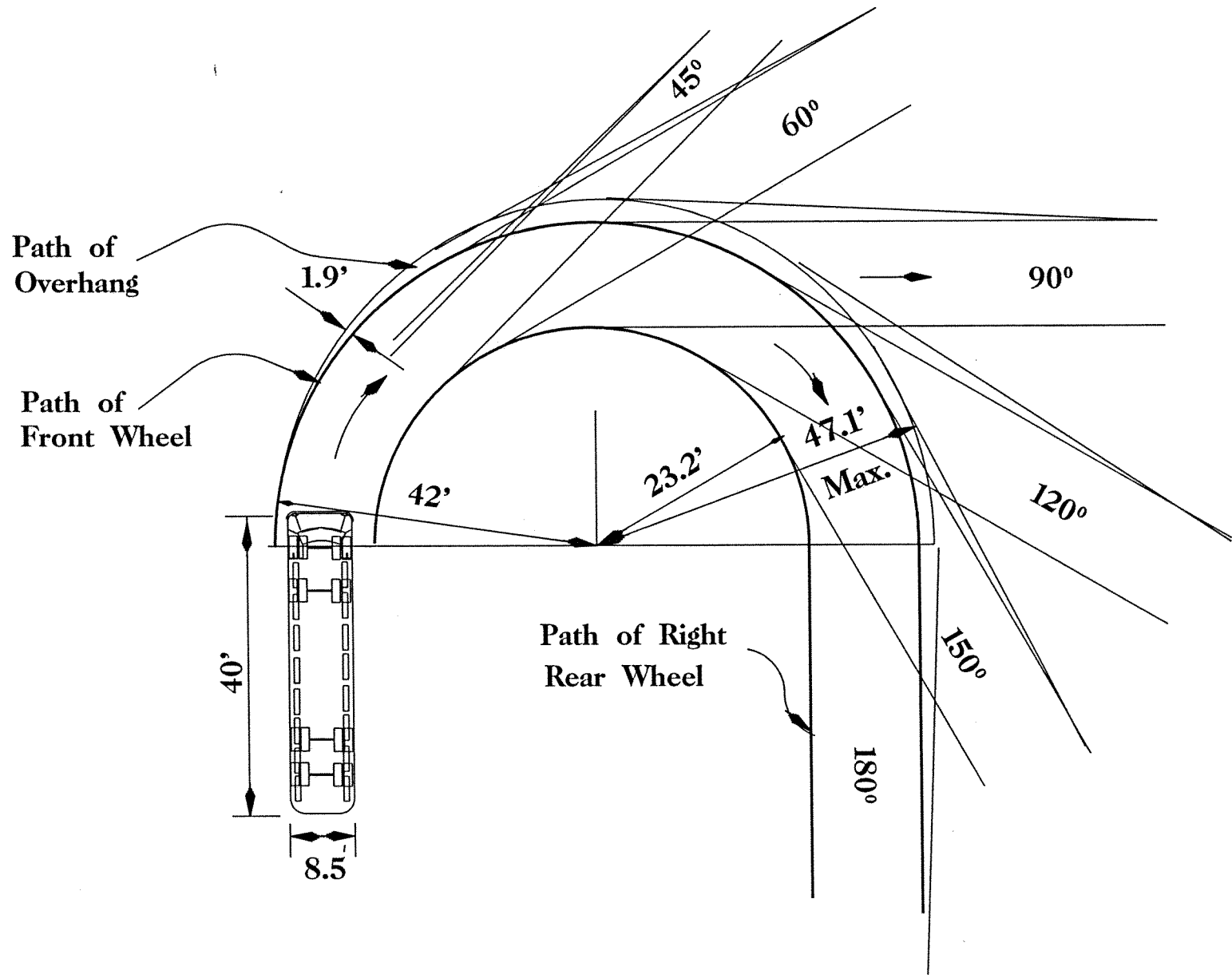

- Scale: 1" = 20'-

For Reference Purposes Only, For Design Use AASHTO Template (1994)

Figure 23: "Bus" Design Vehicle

Department of Development Services / Engineering Division



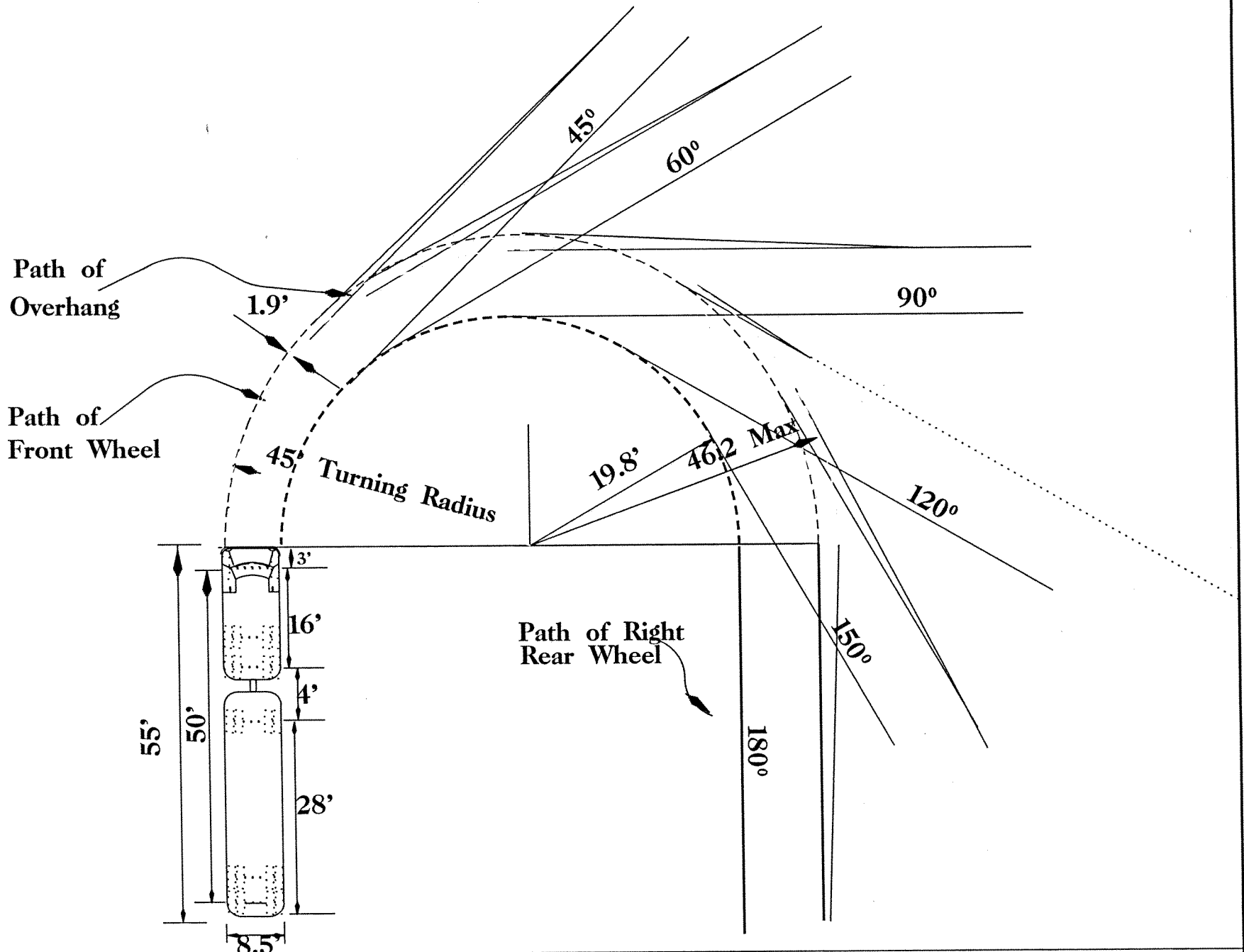

- Scale: 1" = 20' -

For Reference Purposes Only, For Design Use AASHTO Template (1994)

Figure 24: "WB-50" Semi-Trailer Combination Vehicle

Department of Development Services / Engineering Division



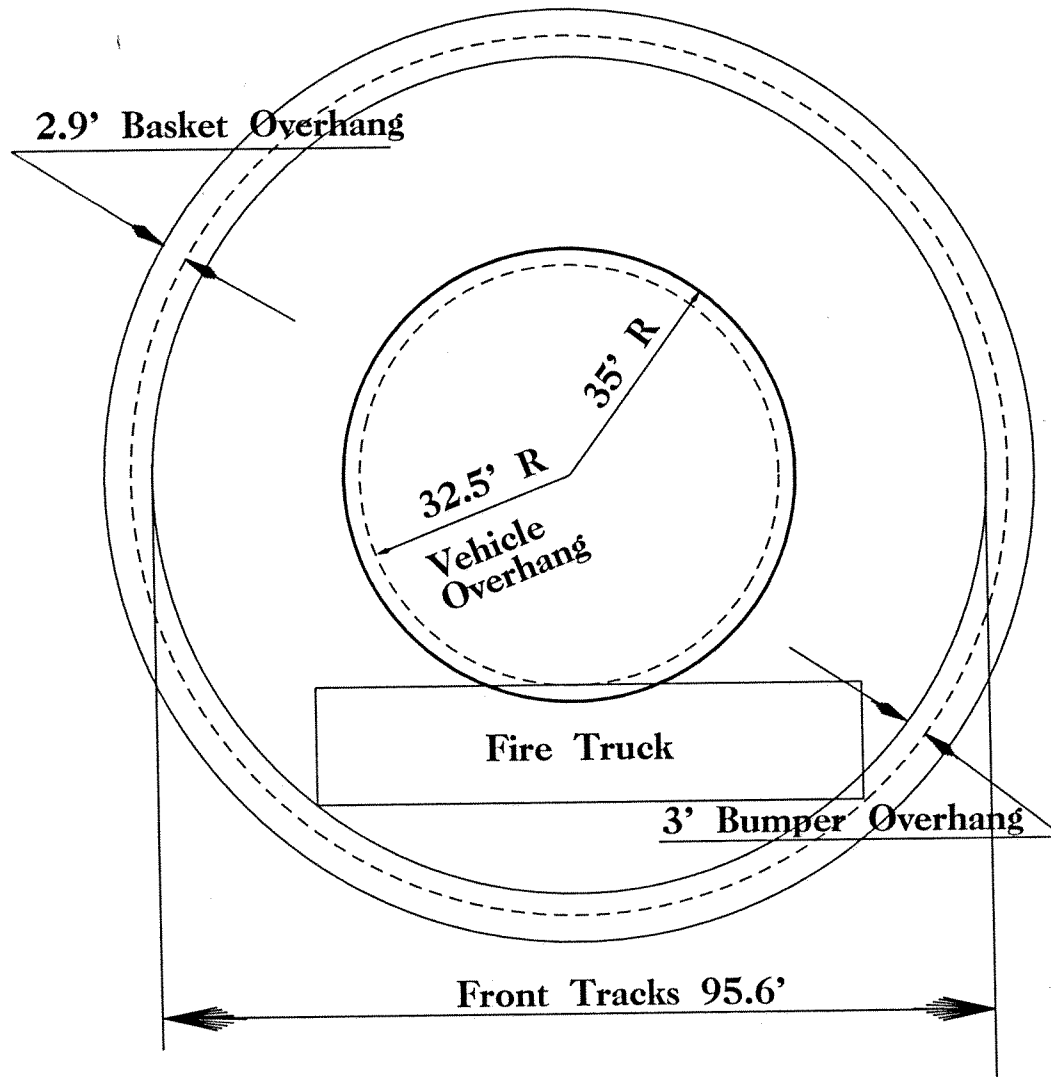

- Not To Scale -

For Reference Purposes Only, For Design Use AASHTO Template (1994)

Figure 25: Fire Truck Turning Template

Department of Development Services / Engineering Division



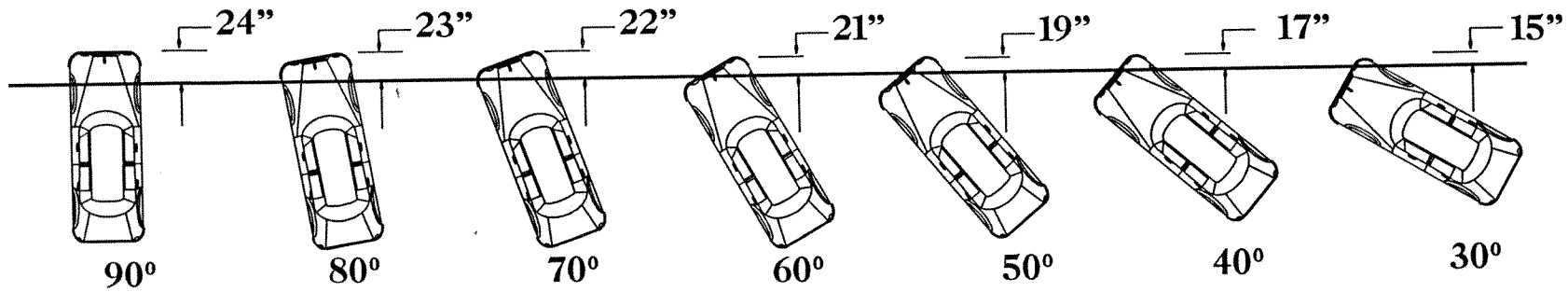

Standard Sized Automobiles

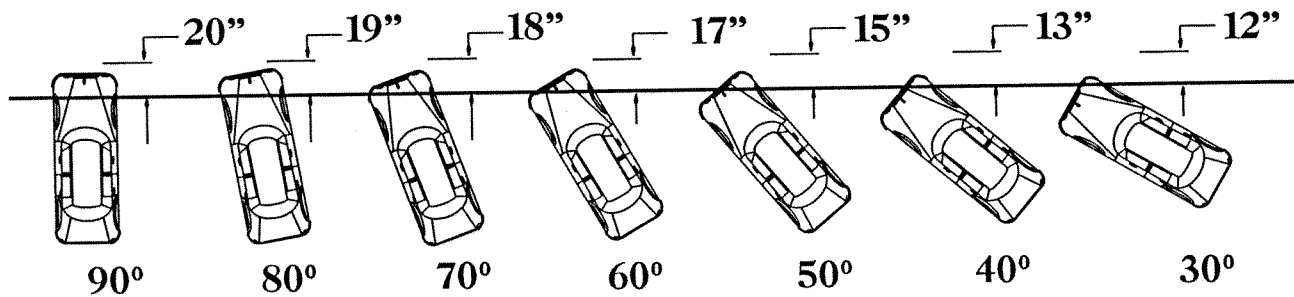

Compact Sized Automobiles

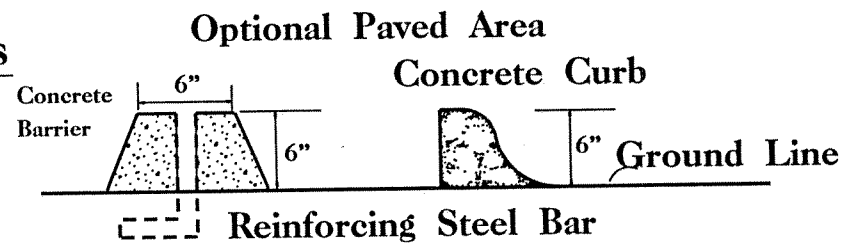

Wheel Guard

- Not To Scale -

Figure 26: Automobile Overhang Dimensions

Department of Development Services / Engineering Division



* Dimensions may be other sizes as noted
in Table 11

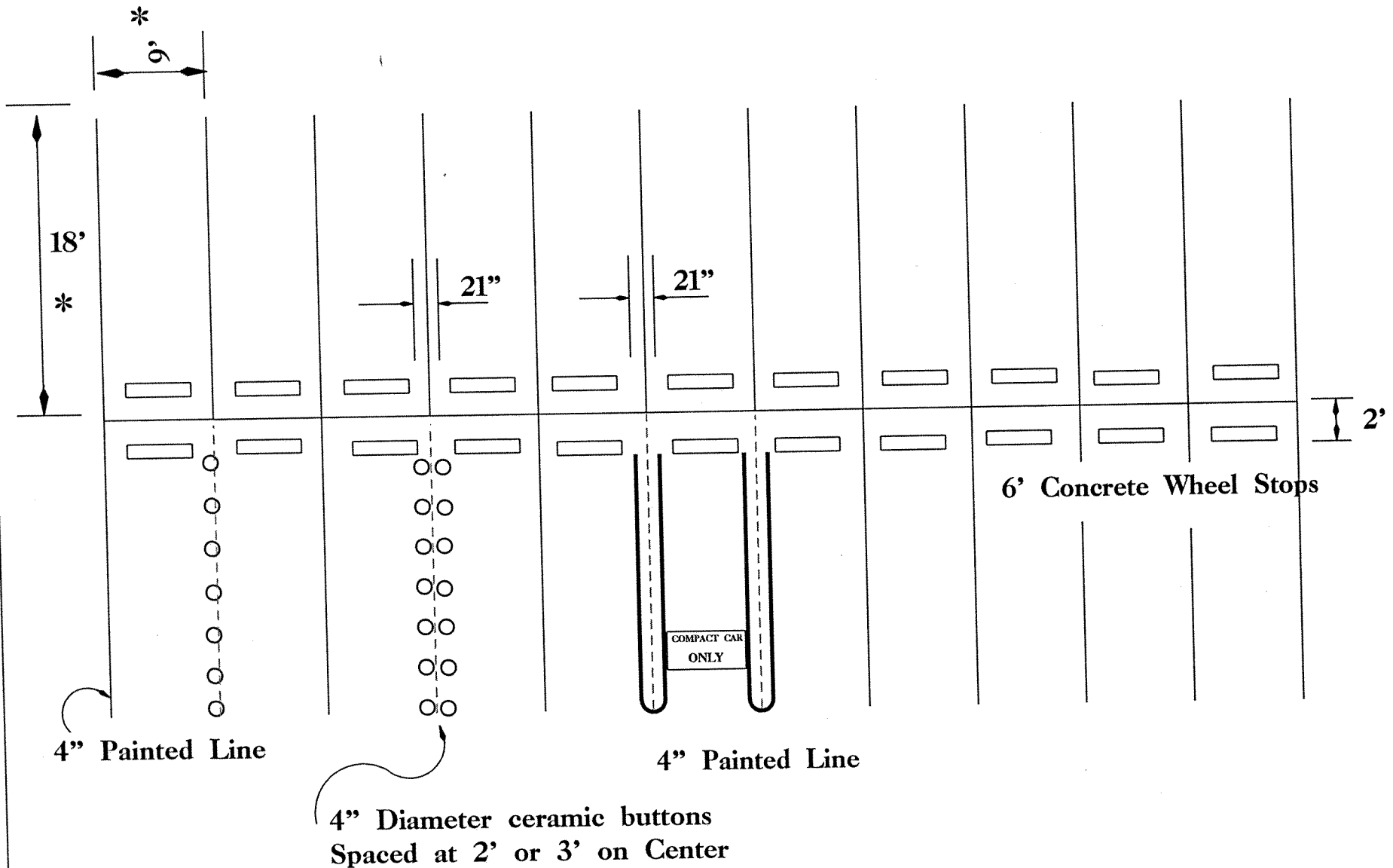

- Not To Scale -

Figure 27: Methods for Marking Parking Stalls

Department of Development Services / Engineering Division



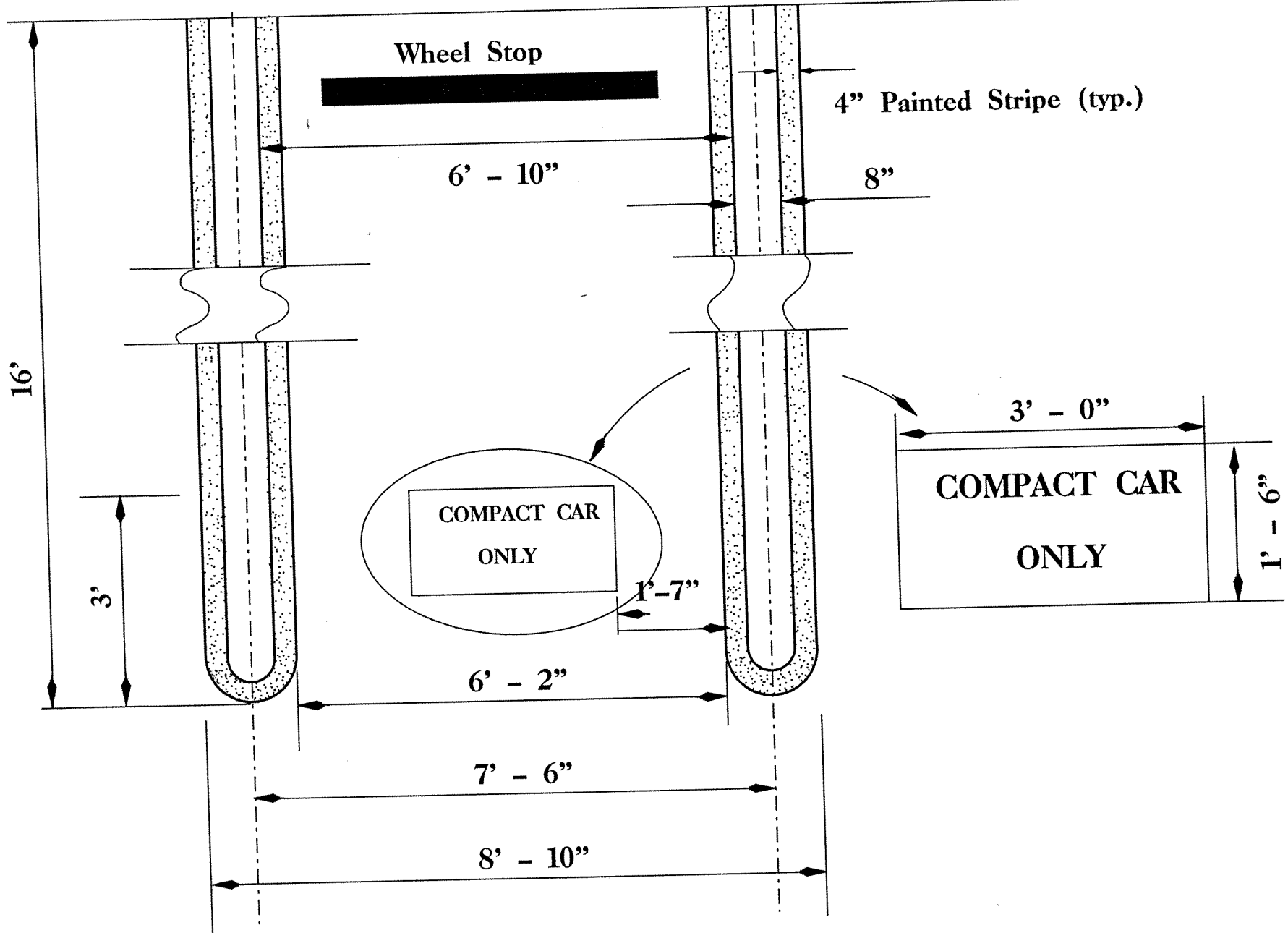

- Not To Scale -

Figure 28: Striping Detail for Compact Car Spaces

Department of Development Services / Engineering Division



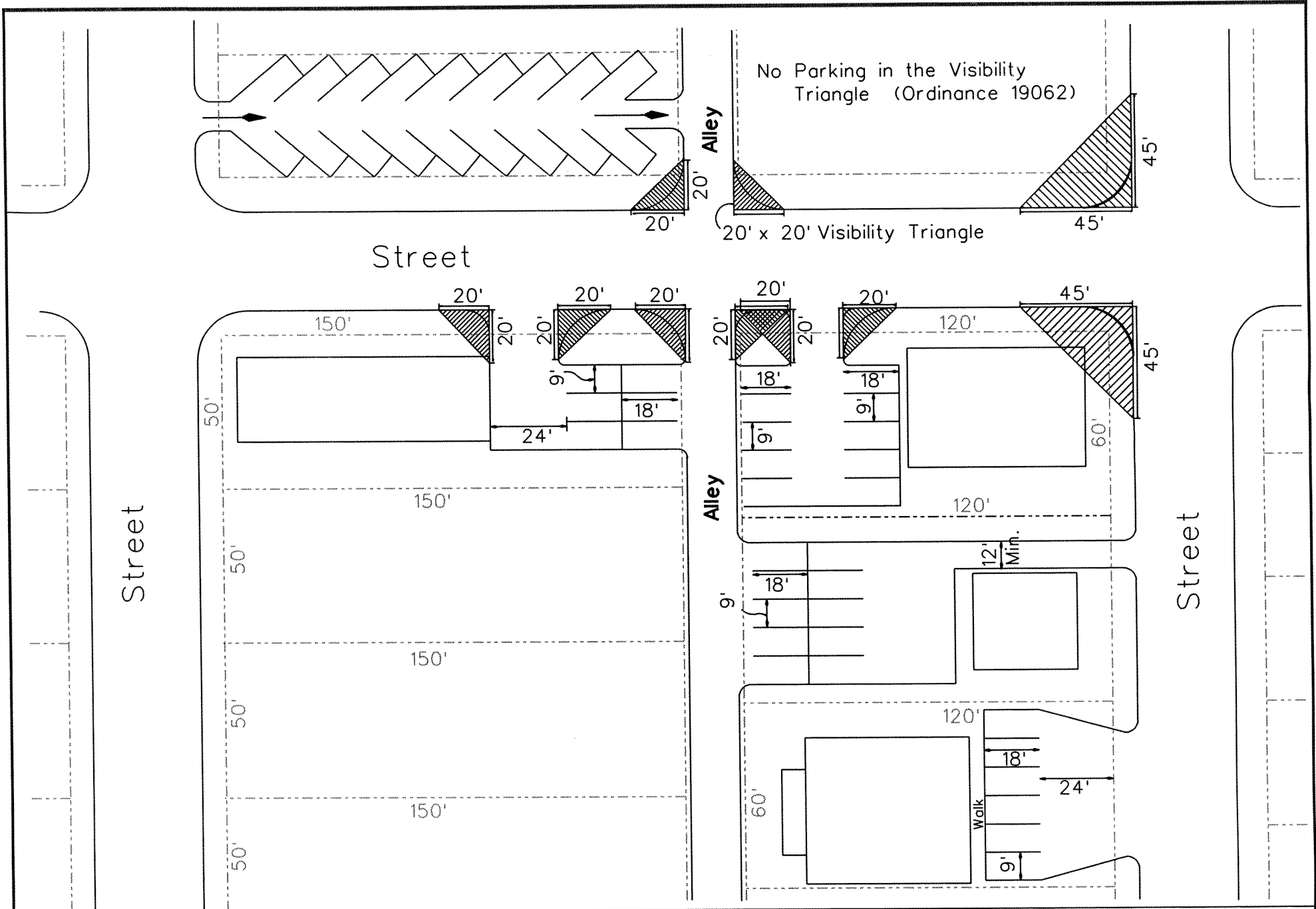

- NOT TO SCALE -

Reference : Dallas City Code 51A-4.301

FIGURE 29: SAMPLE LAYOUT FOR PARKING ON 50' & 60' LOTS

Department of Development Services / Engineering Division